

United States District Court,  
E.D. Pennsylvania.

**NEXANS INC,**  
Plaintiff.

v.

**GENERAL CABLE TECHNOLOGIES CORPORATION and General Cable Industries, Inc,**  
Defendants.

**General Cable Technologies Corporation and General Cable Industries, Inc,**  
Counterclaimants.

v.

**Nexans Inc,**  
Counterdefendant.

**Dec. 11, 2008.**

**Background:** Manufacturer of copper and fiber optic cable products brought action for a declaratory judgment of non-infringement, invalidity and unenforceability of patent for a paired electrical cable having improved transmission properties and method for making the same.

**Holdings:** In construing disputed claim terms, the District Court, Robert F. Kelly, Senior District Judge, held that:

- (1) preamble term "individually twisted balanced cable pair" was a positive limitation which restricted the scope of the claims, and therefore it was necessary to construe the language, and
- (2) term "second twist length," meant that the second twist length may be the same as or different than the first twist length.

Claims construed.

5,767,441. Construed.

Gary Allen Rosen, Law Offices of Gary A. Rosen, PC, Philadelphia, PA, James S. Blank, Joseph M. Drayton, Tzung-Lin Fu, Kaye Scholer LLP, New York, NY, Oliver C. Bennett, Kaye Scholer LLP, London England, for Plaintiff.

Dennies Varughese, Blank Rome LLP, Philadelphia, PA, Thomas C. Martin, Blank Rome LLP, Washington, DC, for Defendant General Cable Technologies Corporation.

### ***MEMORANDUM***

**ROBERT F. KELLY, Senior District Judge.**

### ***INTRODUCTION***

This is an action brought by Nexans Inc. for a Declaratory Judgment of Non-Infringement, Invalidity and Unenforceability of General Cable's U.S. Patent No. 5,767,441 entitled "Paired Electrical Cable Having Improved Transmission Properties and Method for Making the Same" (the "'441 Patent").

Nexans is a manufacturer of copper and fiber optic cable products. These cable products are used for high speed data and voice transmissions, such as, in Local Area Networks or "LANs". In the year 2006 General Cable brought the '441 patent to Nexans attention. Nexans contends that it does not use the technology disclosed in the '441 patent for the manufacture of its communication cables and instead uses technology

which it claims pre-dates the invention of the '441 patent. According to Nexans, General Cable has refused to withdraw its allegations of infringement, prompting Nexans to bring this declaratory judgment action in order to remove the uncertainty caused by General Cable's claims.

### **TECHNICAL BACKGROUND**

The '441 Patent Application was filed on January 4, 1996 and issued on June 16, 1998. The '441 patent "relates generally to paired electrical cables used for transmitting digital and analog data and voice information signals...." ('441 patent at col. 1, lines 7-9.) As noted in the '441 patent, the increased use of computer and telecommunications networks has made it "imperative that the highest quality be achieved in the transmission and voice information signals over ever increasing distances." ( *Id.* at col. 1, lines 23-25.) Accordingly, the "[t]he ability to transmit such information at the highest possible rate and with a minimum number of errors" are identified as "two critically important features" of paired electrical cables used in "any high quality analog or digital signal transmission system." ( *Id.* at col. 1, lines 23-29.)

The ability of paired electrical cables to transmit high frequency signals with minimum error is directly related to their conductor-to-conductor spacing. As illustrated below, conductor-to-conductor spacing-identified by the dimension "S"-refers to the relative distance of the conductors from one another at any given point along the length of the cable:

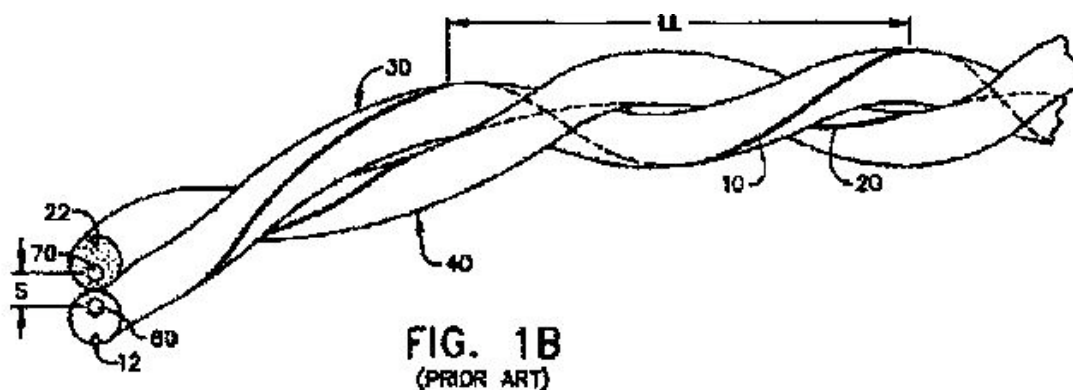

"[I]n order to achieve the optimum electric performance the conductor-to-conductor spacing must be constant and non-changing throughout the cables length." ( *Id.* at col. 4, lines 51-53.) Variations in conductor-to-conductor spacing along the length of the cable give rise to signal reflections which adversely affect the transmission parameters of the cable such as "structural return loss" and "cross talk". (See, e.g., *Id.* at col. 2, lines 7-22, col. 8, line 28, col. 9, line 18.)

Paired electrical cables used for transmission of digital and voice information signals are typically comprised of insulated copper wires which have been twisted together. ( *Id.* at col. 1, lines 31-34.) The transmission properties of these cables, however, can be limited due to imperfections introduced "during the fabrication of the individual insulated wires...." ( *Id.* at col. 1, lines 41-49.) These include "asymmetrical imperfections such as ovality of the surrounding insulation, out-of roundness or eccentricity of the wire cross section and lack of perfect centering of the wire within the insulation...." ( *Id.* at col. 1, lines 35-49.) When the insulated wires are combined together to form a cable, these imperfections naturally give rise to conductor-to-conductor spacing variations which may "limit their ability to transmit data without an insignificant amount of error." ( *Id.* at col. 1, lines 40-41.)

### **APPLICABLE LAW OF CLAIM CONSTRUCTION**

"It is a 'bedrock principle' of patent law that 'the claims of a patent define the invention to which the patentee is entitled the right to exclude.'" *Phillips v. AWH Corp.*, 415 F.3d 1303, 1312 (Fed.Cir.2005) ( *en banc*), *cert. denied*, 546 U.S. 1170, 126 S.Ct. 1332, 164 L.Ed.2d 49 (2006) (quoting *Innova/Pure Water, Inc. v. Safari Water Filtration Sys., Inc.*, 381 F.3d 1111, 1115 (Fed.Cir.2004)). The starting point for construing

the claims is the patent's intrinsic evidence, which includes the claim language itself, the patent specification, and the corresponding prosecution history of the patent. See, Phillips, 415 F.3d at 1312, 1314; C.R. Bard, Inc. v. United States Surgical Corp., 388 F.3d 858, 861 (Fed.Cir.2004); Bell Atl. Network Servs., Inc. v. Covad Commc'ns Group, Inc., 262 F.3d 1258, 1267 (Fed.Cir.2001); Ad in the Hole Int'l Inc. v. Napex, 1999 WL 106905, at \*1-2, 1999 U.S. Dist. LEXIS 2073, at \*3-4 (E.D.Pa. February 25, 1999) (Ludwig, J.).

"[T]he claims are 'of primary importance, in the effort to ascertain precisely what it is that is patented.' " Phillips, 415 F.3d at 1312, quoting Merrill v. Yeomans, 94 U.S. 568, 570, 24 L.Ed. 235 (1876). To begin, claim terms are to be construed with their "ordinary and accustomed" meaning as viewed by one of ordinary skill in the art at the time of the invention. Moba v. Diamond Automation, 325 F.3d 1306, 1315 (Fed.Cir.2003), on remand at 2004 WL 1945566, 2004 U.S. Dist. LEXIS 17722 (E.D.Pa. Aug. 31, 2004) ("[T]he best indicator of claim meaning is its usage in context as understood by one of skill in the art at the time of invention."). The patent's intrinsic record supplies the technological and temporal context. See, Nazomi Commc'ns, Inc. v. Arm Holdings, PLC, 403 F.3d 1364, 1368 (Fed.Cir.2005); Vitronics Corp. v. Conceptronic, Inc., 90 F.3d 1576, 1582 (Fed.Cir.1996).

"When different words or phrases are used in separate claims, a difference in meaning is presumed." Tandon Corp. v. United States Int'l Trade Comm'n, 831 F.2d 1017, 1023 (Fed.Cir.1987). Additionally, terms in a patent claim should not be construed such that they render other terms in the claims superfluous. Texas Instruments v. United States Int'l Trade Comm'n, 988 F.2d 1165, 1171 (Fed.Cir.1993). "Courts can neither broaden nor narrow the claims to give the patentee something different than what he has set forth." Autogiro Co. of Am. v. United States, 181 Ct.Cl. 55, 384 F.2d 391, 396 (1967); see also Texas Instruments, 988 F.2d at 1171 (refusing to adopt a proposed construction that rendered other claim language superfluous).

Claims are often written in a hierarchy, with independent claims as the broadest claims and a series of dependent claims having more narrow scope. See, 35 U.S.C. s. 112, fourth paragraph (2007). Differences among the claim terms may aid in interpreting the claims. Tessera, Inc. v. Micron Tech., Inc., 423 F.Supp.2d 624, 627 (E.D.Tex.2006) (citing Phillips, 415 F.3d at 1314).

[1] [2] [3] The doctrine of claim differentiation creates a presumption that, where a dependent claim is more specific than the independent claim from which it depends, the independent claim must be broader and not limited to the specifics of the dependent claim. This doctrine arises from "the common sense notion that different words or phrases used in separate claims are presumed to indicate that the claims have different meanings and scope." Seachange Int'l, Inc. v. C-COR Inc., 413 F.3d 1361, 1368 (Fed.Cir.2005). "For example, when a dependent claim adds a limitation to an independent claim, it is presumed that the independent claim does not include the limitation." Tessera, 423 F.Supp.2d at 627 (citing Phillips, 415 F.3d at 1314-15). As a general rule, the presence of a dependent claim that adds a particular limitation creates a presumption that the limitation in question is not part of the independent claim. Wenger Mfg., Inc. v. Coating Mach. Sys., Inc., 239 F.3d 1225, 1233 (Fed.Cir.2001); Seachange, 413 F.3d at 1368. This presumption is especially strong where the only meaningful difference between the independent claim and the dependent claim is the limitation at issue. D.M.I., Inc. v. Deere & Co., 755 F.2d 1570, 1574 (Fed.Cir.1985); Liebel-Flarsheim Co. v. Medrad, Inc., 358 F.3d 898, 910 (Fed.Cir.2004). Moreover, if "some claims are broad and others narrow, the narrow claim limitations cannot be read into the broad whether to avoid invalidity or to escape infringement." Uniroyal, Inc. v. Rudkin-Wiley Corp., 837 F.2d 1044, 1054-55 (Fed.Cir.1988); Kalman v. Kimberly-Clark Corp., 713 F.2d 760, 770 (Fed.Cir.1983), *overruled on other grounds by* SRI Int'l v. Matsushita Elec. Corp., 775 F.2d 1107 (Fed.Cir.1985).

[4] While the specification is the primary source to be consulted during claim construction, it may not be used to limit the claims unless it includes words or expressions of manifest exclusion or explicit disclaimers. Howmedica Osteonics Corp. v. Tranquil Prospects, Ltd., 401 F.3d 1367, 1375 (Fed.Cir.2005). Moreover, claims should not be construed such that they are "limited to devices which operate precisely as the embodiments described in detail in the patent." Virginia Panel Corp. v. MAC Panel Co., 133 F.3d 860, 866 (Fed.Cir.1997). "Although the specification may aid the court in interpreting the meaning of disputed claim language, particular embodiments and examples appearing in the specification will not generally be read into the claims." Comark Commc'ns, Inc. v. Harris Corp., 156 F.3d 1182, 1187 (Fed.Cir.1998); see also, Phillips, 415 F.3d at 1323.

***CLAIM TERMS TO BE CONSTRUED***

The parties have agreed on the construction of several terms of the '441 patent. The terms not agreed to are set forth and discussed in detail below.

General Cable has accused Nexans of infringing Claims 12-14 and 22-24 of the '441 patent.

Assert Claim 12 recites: FN1

FN1. The claim terms for construction (both agreed and disputed) are highlighted.

An **individually twisted balanced cable pair** suitable for **long line data transmission**, comprising:

(a) a first insulated wire that is **pre-twisted around its own longitudinal axis** at a **predetermined lay length**;

(b) a second insulated wire that is **pre-twisted around its own longitudinal axis** at the same **predetermined lay length** as said first insulated wire; and

(c) said first and second insulated wires being **twisted together**, thereby forming a **cable pair**.

Claim 13 of the '441 patent recites:

The **cable pair** as recited in claim 12, wherein said first and second insulated wires are **pre-twisted** in one rotational direction, then **twisted together** in the direction opposite the direction of said pre-twisting, thereby forming a **cable pair**.

Claim 14 of the '441 patent recites:

The **cable pair** as recited in claim 13, wherein said first and second insulated wires are **pre-twisted** at the same **lay length**.

Claim 22 of the '441 patent recites:

An **individually twisted balanced cable pair** suitable for **long line data transmission**, comprising:

(a) a first insulated wire that is **uniformly pre-twisted around its own longitudinal axis** at a **first twist length**;

(b) a second insulated wire that is **uniformly pre-twisted around its own longitudinal axis** at a **second twist length**; and

(c) said first and second insulated wires being **twisted together**, thereby forming a **cable pair**.

Claim 23 of the '441 patent recites:

The **cable pair** as recited in claim 22, wherein said first and second insulated wires are **twisted together** around a common axis.

Claim 24 of the '441 patent recites:

The **cable pair** as recited in claim 22, wherein said first and second insulated wires are **twisted together** at a combined uniform **twist length**.

***INDIVIDUALLY TWISTED BALANCED CABLE PAIR, TWISTED TOGETHER AND CABLE PAIR***

*INDIVIDUALLY TWISTED BALANCED CABLE PAIR, TWISTED TOGETHER AND CABLE PAIR*

*General Cable's Proposed*

*Nexans' Proposed*

<i>Claim Term</i>	<i>Construction</i>	<i>Construction</i>
"individually twisted balanced cable pair"	two separately insulated wires twisted about each other, each of the separately insulated wires being electrically alike with respect to a common reference point	(1) Preamble-not a claim limitation  (2) Plain meaning-no construction necessary  (3) If construction deemed necessary: "Two separately insulated wires twisted about a common axis, each of the separately insulated wires being electrically alike with respect to a common reference point"
"twisted together"	the process by which two wires are twisted about each other to form a cable pair	(1) Plain meaning-no construction necessary  (2) If construction deemed necessary: "twisted about a common axis"
"cable pair"	two separately insulated wires twisted about each other	(1) Plain meaning-no construction necessary  (2) If construction deemed necessary: "two insulated wires twisted about a common axis"

### ***PREAMBLE***

[6] The parties dispute whether the preamble terms-"individually twisted balanced cable pair" and "long line data transmission"-are positive limitations which restrict the scope of the claims. General Cable contends that they are positive claim limitations, Nexans disputes that contention. We need only construe the terms in the preamble if we first find that they are positive claim limitations.

[7] [8] The claim "preamble" is the introductory portion of the claim that describes the invention in more general terms than the rest of the claim, typically appearing before the transition term "comprising". There is no litmus test that defines precisely when a preamble should be construed as a claim limitation. *Corning Glass Works v. Sumitomo Elec., U.S.A. Inc.*, 868 F.2d 1251, 1257 (Fed.Cir.1989). As a general rule, a preamble "limits the claimed invention if it ... is 'necessary to give life, meaning, and vitality' to the claim." *In re: Cruciferous Sprout Litigation*, 301 F.3d 1343, 1347 (Fed.Cir.2002). (citations omitted). Moreover, "[c]lear reliance on the preamble during prosecution to distinguish the claimed invention from the prior art may indicate that the preamble is a claim limitation because the preamble is used to define the claimed invention." *In re: Cruciferous Sprout Litigation*, 301 F.3d at 1347. *Bristol-Myers Squibb Co. v. Ben Venue Labs., Inc.* 246 F.3d 1368, 1375 (Fed.Cir.2001).

According to Nexans, the term "individually twisted balanced cable pair" should not be construed as a claim limitation because "the express language of the claims, the specification and the prosecution history establish that the preamble terms are not limiting." Nexans Opening Claim Construction Brief ("Nexans Opening Br.") at 29. Nexans agrees, however, that where there is "clear and unmistakable reliance" on the preamble language to overcome prior art, the preamble may be limiting. *Id.* at 30. The parties agree that the patentee added the feature "individually twisted balanced cable pair" to overcome a rejection based on the Palmer and Dzurak Patents. A portion of the prosecution history states:

**The cables described in Palmer are unbalanced and asymmetrical** (note the title of the patent). **In contrast, the present cables are balanced and symmetrical** as is required for long line data transmission with only minimal errors. The entire purpose of the present invention, in fact, is to eliminate data transmission problems which are caused by cable asymmetries (see pg. 1, lines 20-27 of the present application).

G.C. Opposition Brief, Ex. 2 at 6 (emphasis added).

I find that the patentee relied upon the feature "individually twisted balanced cable pair" to overcome the Examiner's rejection.

[9] Where a patentee relies upon the preamble during prosecution the preamble must be construed. *Catalina Mktg. Int., Inc. v. Coolsavings.com, Inc.*, 289 F.3d 801 (2002). The fact that the patentee relied on more than one amendment during the prosecution does not change the rule, and no contrary law has been cited by the parties.

Nexans contends that the preamble is not limiting because it merely describes the use or purpose of the invention and therefore generally would not be treated as limiting the scope of the claim. *Bicon, Inc. v. The Straumann Co.*, 441 F.3d 945, 952 (Fed.Cir.2006). This is because the patentability of apparatus or composition claims depends on the claimed structure not on the use or purpose of that structure. *Catalina*, 289 F.3d at 809. Nexans Opening Brief at 29.

The words "individually twisted balanced cable pair" as both sides agree, connotes that "each of the separately insulated wires [are] electrically alike with respect to a common reference point." Nexans Opening Brief at 34; G.C.'s Opposition Brief at 4. In order to be electrically alike, the separately insulated wires must have certain physical characteristics. This is a structural limitation on the claim that results in a cable pair having specific electrical characteristics.

Nexans cites the case of *DP Wagner Mfg. v. Pro Patch Sys.*, 2006 WL 1766182 (S.D.Tex.), which concerned a repair patch that could be used to repair many different types of surfaces. The Court concluded that the many references in the preamble to a "vehicle body surface repair patch" did not limit the claim to similar patches used to repair automobiles when the same patch could be used to repair drywall. It was merely a statement of intended use with no differences from the applied prior art. Unlike the present case where the preamble words "individually twisted balanced cable pair" connotes that "each of the separately insulated wires [are] alike with reference to a common reference point". Nexans Opening Brief at 34. This is a structural limitation on the claims that results in a cable pair having specific electrical characteristics, as the patentee explained to the examiner during the prosecution of the '441 patent. Therefore, the *DP Wagner* case does not apply to the present situation.

Nexans also points to the case of *Schumer v. Lab. Computer Sys., Inc.*, 308 F.3d 1304 (Fed.Cir.2002). There the Court held that the language of the body of the claim "sets out the complete invention" in that it provides in detail the functional attributes of the device that performs the methods. The Court went on to say that this is a situation where the language of the preamble is superfluous. In the present case there is nothing to support the proposition that "individually twisted balanced cable pair" describes features that necessarily exist in the claimed invention. As General Cable points out in its Opposition Brief, if that were the case, the examiner would not have applied unbalanced cable pairs to reject the claims of the application that ultimately became the '441 patent. The words "individually twisted balanced cable pair" provide a structural limitation on the claims that gives "life, meaning and vitality to the claims" and must be construed. *Pitney Bowes, Inc. v. Hewlett-Packard Co.*, 182 F.3d 1298, 1305 (Fed.Cir.1999).

Nexans also relies on the case of *Intirtool, Ltd. v. Texar Corp.*, 369 F.3d 1289, 1296 (Fed.Cir.2004). Where the Court held that the preamble of the patent claim did not add limitations to the claim because the preamble simply recited "benefits or features" of the claimed invention and the Court did not see "clear reliance on those benefits or features as patentably significant." That case does not apply to our present situation because here the patentee clearly relied upon the words "individually twisted balanced cable pair" as patentably significant to distinguish it over the reference applied by the examiner during the prosecution.

I find that it is therefore necessary to construe the language of the preamble.

[10] In addition to alleging that the preamble was not a claim limitation as discussed earlier, Nexans contends that this claim needs no construction. However, where Nexans disagrees with General Cable's proposed construction, construction of the term is required. See, *O2 Micro v. Beyond Innovation Technology Co. Ltd.*, 521 F.3d 1351, 1362 (Fed.Cir.2008). "When the parties present a fundamental dispute regarding the scope of a claim term, it is the Court's duty to resolve it" by construing that term. I find that the parties have presented such a dispute and that the claim terms must be construed.

In arguing in support of its construction Nexans points to the specifications of the '441 patent at (col. 1, lines 60-64); ( id. at col. 4, lines 40-45.); ( id. at col. 9 lines 19-22) and ( id. at col. 10 lines 13-27.) To support its construction "twisted about a common axis" Nexans argues that "[n]o where does the specification describe the twisting of the two wires "about each other" as General Cable proposes."

In support of its construction General Cable points to the specifications, where the wires are twisted together into cable pairs. '441 patent at col. 2, lines 41-44, "after these wires have been twisted together into cable pairs ...." ( Id. at col. 6, lines 32-46), which refers to fig. 1C (see Attachment # 1) which includes cross-sectional views at various distances along the length of one individually twisted cable pair, where it is obvious from viewing fig. 1C that the wires have been twisted together; id. at col. 7, lines 1-3, referring to fig. 3D (see Attachment # 2) showing an individually twisted cable pair which have been twisted together; id. at col. 10, lines 23-29 referring to "Pairing by a conventional double twist method accomplishes the result shown on fig. 3B (see Attachment # 3) in which an individually twisted pair, designated by index numeral 120 is created from wires 80 and 90 which are lay twisted about a common axis ...."

In its opposition brief General Cable argues that Nexans' proposed constructions are also flawed because they disregard the elements recited in dependent claim 23 which states:

The cable pair as recited in claim 22, wherein said first and second insulated wires are twisted together around a common axis.

General Cable goes on to argue that even though claim 23 explicitly requires that the first and second insulated wires are "twisted together around a common axis.", Nexans' construction would require that "[about] a common axis" be imported from claim 23 into claims 12 and 22 by construing "individually twisted balanced cable pair," "twisted together", and "cable pair" to include a limitation expressly recited in claim 23.

As General Cable points out the limitations Nexans seeks to import from claim 23 are the only meaningful difference between claim 23 and claims 12 and 22. This raises a strong presumption that the limitation in question is not to be found in the independent claims. As the Court stated in the case of *Liebel-Flarsheim v. Medrad, Inc.*, 358 F.3d 898, 910 (Fed.Cir.2004) "[t]he presence of a dependent claim that adds a particular limitation raises a presumption that the limitation in question is not found in the independent claim." We recognize, as Nexans points out, that this is a presumption that can be rebutted, however, we find nothing in this record that would convince us to overrule this presumption. Nexans' proposed constructions would render claim 23 meaningless and we will not adopt it.

[11] The claim term "individually twisted balanced cable pair" means two separately insulated wires twisted about each other, each of the separately insulated wires being electrically alike with respect to a common reference point. The claim term "twisted together" means the process by which two wires are twisted about each other to form a cable pair. The claim term "cable pair" means two separately insulated wires twisted about each other.

#### *LONG LINE DATA TRANSMISSION*

<i>Claim Term</i>	<i>General Cable's Proposed Construction</i>	<i>Nexans' Proposed Construction</i>
"long line data transmission"	the length of the line is many times longer than the wavelength of the highest frequency transmitted	(1) Preamble-not a claim limitation

(2) transmission over distances longer than 1/8 of the wavelength of the highest frequency transmitted

[12] Nexans first contends that the preamble words "long line data transmission" are not claim limitations and should not be construed. However, during the prosecution, independent claims 12 and 22 were amended to recite the feature "suitable for long line data transmission." G.C.'s Opposition Brief, Ex. 6 at pgs. 2-3. The patentee described that the claimed invention was distinct from the references applied by the examiner because:

The present invention relates to balanced symmetrical cables which are suitable for long line data transmission (i.e. *the length of the line is many times longer than the wavelength of the highest frequency transmitted*). These cables have been shown to have superior transmission properties (minimal structural return loss, near end cross talk and insertion loss) when compared to prior art cables ...

G.C.'s Opposition Brief, Ex. 6 at p. 6 (emphasis added).

The patentee distinguished the references applied by the examiner by amending the claims to recite "suitable for long line data transmission" and arguing that the cables shown in the prior art references were not suitable for "long line data transmission." The patentee further explained that "[t]he Palmer cables are used for low frequency transmission over short cable lengths (as would be used in audio hookups) and would not be suitable for use in long line data transmission." G.C.'s Opposition Brief, Ex. 6 at p. 6. Based, at least in part, on these arguments, the examiner withdrew her rejections and allowed the '441 patent to issue.

Therefore the prosecution history "shows a clear reliance by the patentee on the preamble to persuade the Patent Office that the claimed invention is not anticipated by the prior art ... the preamble is a limitation of the claims." In *Re: Cruciferous Sprout Litigation*, 301 F.3d at 1347. Because the patentee relied upon the feature of "long line data transmission" to overcome a rejection based on prior art, this term will be interpreted as a claim limitation.

[13] It is clear from the intrinsic evidence that the words "long line data transmission" are to be construed to mean "the length of the line is many times longer than the wavelength of the highest frequency transmitted." When General Cable amended its application to add the words suitable for long line data transmission, the applicant also included the definition of those terms within the amendment. Because the intrinsic evidence is clear I find that the extrinsic evidence cited by Nexans is not relevant.

*PRE-TWISTED AROUND ITS OWN LONGITUDINAL AXIS*

<i>Claim Term</i>	<i>General Cable's Proposed Construction</i>	<i>Nexans' Proposed Construction</i>
"pre-twisted around its own longitudinal axis"	the wires is twisted around its longitudinal axis prior to pairing with the other wire	twisted around its own axis prior to the process of forming a cable pair

[14] General Cable argues that the '441 patent describes that "[b]efore pairing, one or both of the insulated wires is pre-twisted about its own longitudinal axis such that the relative degree of pre-twist in the two wires is the same or different." '441 patent, col. 4, lines 37-40. Additionally, the '441 patent describes at col. 10, lines 13-18:

In a preferred embodiment depicted in FIGS. 3A and 3B, a first wire 80 is pre-twisted before being paired with another wire 90 in a conventional double twist machine. In the example of FIG. 3A, a "spiraled" stripe 100 on the insulated surface of wire 80 indicates a **pre-twist of one complete 360 degree revolution about its longitudinal axis.**

General Cable goes on to argue, that the '441 patent specifically describes pre-twisting about the wires longitudinal axis before that wire is brought together with another wire to form a pair. According to General Cable this pre-twisting can happen as part of the process of forming a cable pair, so long as it occurs at a



point in the process before the wires are brought together.

Nexans argues that its construction is consistent with the teachings of the specifications, and that the "pre" in "pre-twisted" means-"the insulated wire must be twisted **before** that wire is used in the **process** of forming a cable pair (e.g., by being loaded into the payoffs of a conventional double twist machine.) Any twisting of the insulated wires that occurs **during** this pairing process (as disclosed in the prior art, for example) is thus necessarily excluded." Nexans' Opening Claim Brief at p. 21. Nexans goes on to argue that General Cable's proposed construction would include any twisting of the insulated wires that occurs during the pairing process thereby improperly claiming the very problem (i.e. back twist) that the '441 patent sought to overcome. General Cable does not dispute that one method of pre-twisting described in the specifications involves using a double twist pairing machine to achieve pre-twisting. However, this is one of many embodiments of the present invention contemplated by the inventors, and limiting the scope of the claims to a preferred embodiment absent disclaimer violates Federal Circuit precedent. See, Comark Commc'ns, Inc. v. Harris Corp., 156 F.3d 1182, 1187 (Fed.Cir.1998) where the Court said:

"Appellant misinterprets the principle that claims are interpreted in light of the specification. Although the specification may aid the Court in interpreting the meaning of disputed claim language, particular embodiments and examples appearing in the specifications will not generally be read into the claims." (citations omitted)

See also, Varco L.P. v. Pason Sys., USA Corp., 436 F.3d 1368, 1373 (Fed.Cir.2006) where the Court said:

"in examining the specification for proper context, however, this Court will not at any time import limitations from the specification into the claims." (citations omitted)

Limiting the claims to require that pre-twisting be a separate "process" would unjustly deprive General Cable of the scope of the patent protection to which it is entitled.

According to Nexans, all pre-twisting must occur separately and prior to the "process" of pairing, not simply prior to the point in the process where the insulated wires are paired together. However, none of the intrinsic or extrinsic evidence supports this construction. Nothing in the specification limits the term "pre-twisting" to being a separate process from the pairing process. The specification makes it clear that pre-twisting occurs prior to the twisting together of the wires to form the twisted pair. '441 patent, col. 4, lines 37-40. Therefore, it does not matter whether this pre-twisting is done in a separate process or as part of the pairing process.

Nothing in the extrinsic evidence cited by Nexans limits the term in that fashion. The claim term "pre-twisted around its own longitudinal axis" is construed to mean the wire is twisted around its longitudinal axis prior to pairing with the other wire.

### ***SECOND TWIST LENGTH***

[15] The term "second twist length" appears in claim 22, which recites, in relevant part:

- (a) a first insulated wire that is uniformly pre-twisted around its own longitudinal axis at a first twist length;
- (b) a second insulated wire that is uniformly pre-twisted around its own longitudinal axis at a second twist length ....

The dispute between the parties different constructions of "second twist length" is whether or not the second twist length must be different from the first twist length.

The specifications of the '441 patent at col. 4, lines 37-40 state:

Before pairing, one or both of the insulated wires is pre-twisted about its own longitudinal axis such that the relative degree of pre-twist in the two wires is the same or different.

Also see the '441 patent at lines 55-64 which state:

A variety of pre-twisting combinations may be realized by the present invention. For instance, only one wire may be pre-twisted uniformly or pre-twisted with random amounts while the other is not pre-twisted at all, both may be pre-twisted uniformly or pre-twisted with random amounts, one may be uniformly pre-twisted while the other is pre-twisted with random amounts, or one may be uniformly pre-twisted along a different twist length than the other uniformly pre-twisted wire providing the cycling of conductor-to-conductor spacing to be less than 1/8 wave-length of the highest signal frequency to be carried by the pair.

Nexans points to the case of 3M Innovative Props. Co. v. Avery Dennison Corp., 350 F.3d 1365, 1371 (Fed.Cir.2003) for the proposition that the terms "first" and "second" must be construed differently when both terms are used in the claims of a patent. The context in which those terms are used in that case is much different from our present situation. The 3M Innovative patent claim recited "a multiple embossed pattern having a first embossed pattern and a second embossed pattern ...." The patent in the 3M Innovative case dealt with adhesive backed products for commercial graphics. These are advertisements pre-printed onto sheets of adhesive backed film. These are like bumper stickers that have release liners that can be stripped off to reveal pressure sensitive adhesive just prior to affixing the image. Correct positioning of a large image may require repeated adjustments if the film is not initially placed in precisely the desired position. Also pockets of air, in the form of bubbles or blisters, may become trapped between the film and the surface if not matted properly.

The patent in that case described a release liner that according to 3M avoided these positioning and air entrapment problems. The "first" embossment was a grid with adhesive, the "second" embossment was such that it did not disturb the first, but contained a release agent that protruded above the first and allowed trapped air to escape and also allowed repositioning of the design to correct any error in placement prior to final application.

My point in discussing the facts of this case at such length is that one cannot say the claim required a first and then a second and therefore they must be different. It depends upon the circumstances of each case. In 3M Innovative the problem to be solved required that the first and second be different, otherwise, you are embossing adhesive on the first application and adhesive on the second application which would only make the problem worse. Whereas, in the present case there is no inherent reason to require the "second twist length" to be different from the first twist length.

The real question is, if that is what was meant, why did the applicant not add the words "a second twist length which may be the same or different from the first twist length".

I do not know the answer to that question and General Cable does not offer one. I do know that leaving the words "which may be the same or different" out of the claim was not intentional otherwise the specifications would not have contained the above quoted excerpts. Those portions of the specifications make it clear that the first and second twist lengths may be the same or different. Nexans' proposed construction would limit the meaning of the second twist length to the preferred embodiment. Because the inventors did not disclaim the embodiment in which the first and second twist lengths are the same there is no justification to deprive the inventors of the scope of the protection to which they are entitled. Teleflex, Inc. v. Ficoso N. Corp., 299 F.3d 1313, 1326-27 (Fed.Cir.2002) where the Court declined to limit a claim to a preferred embodiment because there was not evidence of disclaimer.

I therefore construe the words "second twist length" to mean that the second twist length may be the same as or different than the first twist length.

In accordance with the above memorandum we enter the following Order.

**ATTACHMENT # 1**

ATTACHMENT # 1

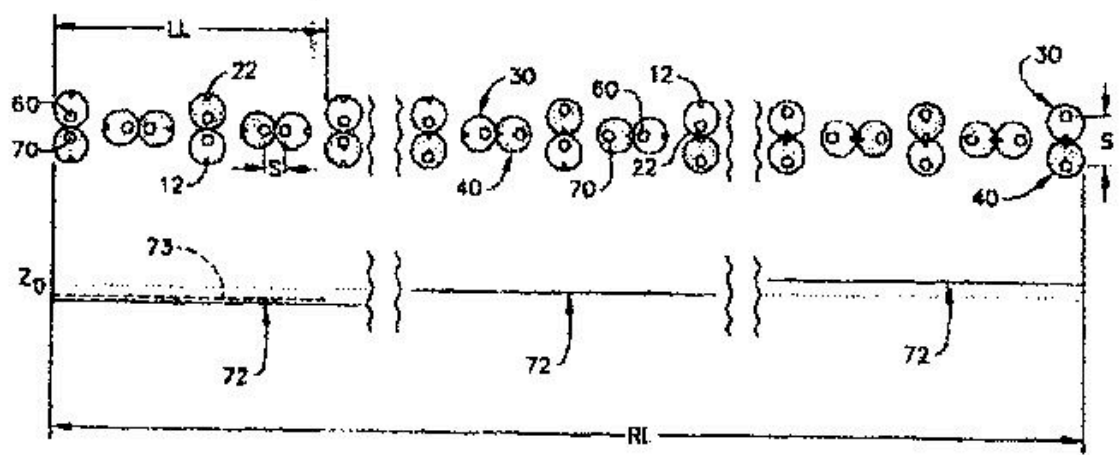

FIG. 1C  
(PRIOR ART)

ATTACHMENT # 2

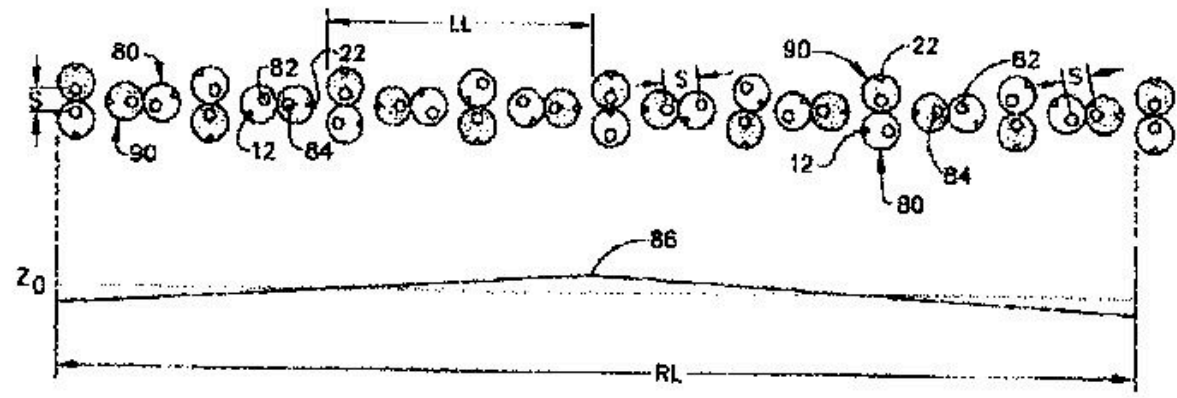

FIG. 3D

ATTACHMENT # 2

ATTACHMENT # 3

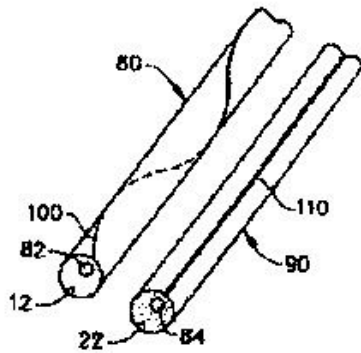

FIG. 3A

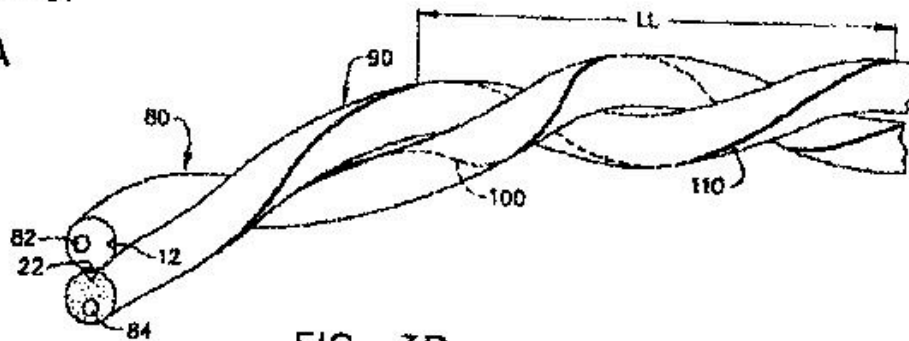

FIG. 3B

**ORDER**

**AND NOW**, this 11th day of December, 2008, it is **ORDERED** that the following claim constructions are adopted:

The claim term "individually twisted balanced cable pair" means two separately insulated wires twisted about each other, each of the separately insulated wires being electrically alike with respect to a common reference point.

The claim term "twisted together" means the process by which two wires are twisted about each other to form a cable pair.

The claim term "cable pair" means two separately insulated wires twisted about each other.

The claim term "long line data transmission" means the length of the line is many times longer than the wavelength of the highest frequency transmitted.

The claim term "pre-twisted around its own longitudinal axis" means the wire is twisted around its longitudinal axis prior to pairing with other wire.

The claim term "second twist length" means that the second twist length may be the same as or different than the first twist length.

E.D.Pa., 2008.

Nexans Inc. v. General Cable Technologies Corp.

Produced by Sans Paper, LLC.

ATTACHMENT # 3