

United States District Court,
E.D. Texas, Tyler Division.

REEDHYCALOG UK, LTD. and Grant Prideco, Inc,
Plaintiffs.

v.

**BAKER HUGHES OILFIELD OPERATIONS INC., Halliburton Energy Services Inc., and U.S.
Synthetic Corporation,**
Defendants.

No. 6:06 CV 222

Oct. 12, 2007.

Danny Lloyd Williams, J. Mike Amerson, Christopher Needham Cravey, James A. Jorgensen, Jeffrey Allen Pfeifer, Matthew Richard Rodgers, Stephen E. Edwards, Williams Morgan & Amerson PC, John C. Cain, Keith Alan Rutherford, Raymond Scott Reese, Wong Cabello Lutsch, Rutherford & Brucculeri, Houston, TX, Sidney Calvin Capshaw, III, Andrew Wesley Spangler, Elizabeth L. Derieux, Nancy Claire Abernathy, Brown McCarroll, Thomas John Ward, Jr., Ward & Smith Law Firm, Longview, TX, for Plaintiffs.

C. Kevin Speirs, Catherine A. Agnoli, David G. Mangum, Michael R. McCarthy, Parsons Behle & Latimer, Salt Lake City, UT, Collin Michael Maloney, Otis W. Carroll, Jr., Ireland Carroll & Kelley, John Frederick Bufe, Michael Edwin Jones, Potter Minton, Tyler, TX, Samuel Franklin Baxter, McKool Smith, Marshall, TX, Jason Dodd Cassady, Lesley David Anderson, Scott Wayne Hejny, Theodore Stevenson, III, McKool Smith, Dallas, TX, for Defendants.

MEMORANDUM OPINION

LEONARD DAVIS, United States District Judge.

This Memorandum Opinion construes the terms in United States Patent Nos. 6,298,930 (the " '0 Patent"); 6,443,249 (the " '249 Patent' "); 6,460,631 (the " '631 Patent"); and 7,000,715 (the " '715 Patent").

BACKGROUND

The patents in issue deal with rotary drill bits. The '249 Patent issued on September 3, 2002, and the '715 Patent, a continuation-in-part of the application that became the '249 Patent, issued on February 21, 2006. The ' 249 and '715 Patents disclose a drill bit with varied cutter geometries and orientations along the drill bit profile. Generally, cutters located close to the centerline of the drill bit have cutter geometries and orientations such that the cutters are less aggressive, while cutters located further from the centerline of the drill bit have cutter geometries and orientations such that the cutters are more aggressive. This variation enhances drill bit stability and allows the drill bit to quickly penetrate the formation under a relatively high amount of weight on the drill bit.

The '0 Patent issued on October 9, 2001, and the '631 Patent, a continuation-in-part of the application that became the '0 Patent, issued on October 8, 2002. The '0 and '631 Patents disclose drill bits that use depth of cut control features to limit how deep the cutters can cut into the formation. These features, located on the drill bit face, contact the formation and allow the cutters to cut the formation only to the extent the cutters protrude past the features. Thus, the drill bit can penetrate formations of different compressive strengths at the same rate, even with a high amount of weight on the drill bit, assuming the depth of cut control features can bear such weight.

Baker Hughes Oilfield Operations Inc. ("Baker Hughes"), the licensee of the '249, '715, '0, and '631 Patents, claims drill bits sold by ReedHycalog UK LTD ("ReedHycalog") infringe various claims of the '249, '715, '0, and '631 Patents.

APPLICABLE LAW

"It is a 'bedrock principle' of patent law that 'the claims of a patent define the invention to which the patentee is entitled the right to exclude.'" Phillips v. AWH Corp., 415 F.3d 1303, 1312 (Fed.Cir.2005) (en banc) (quoting Innova/Pure Water Inc. v. Safari Water Filtration Sys., Inc., 381 F.3d 1111, 1115 (Fed.Cir.2004)). In claim construction, courts examine the patent's intrinsic evidence to define the patented invention's scope. *See id.*; C.R. Bard, Inc. v. U.S. Surgical Corp., 388 F.3d 858, 861 (Fed.Cir.2004); Bell Atl. Network Servs., Inc. v. Covad Commc'ns Group, Inc., 262 F.3d 1258, 1267 (Fed.Cir.2001). This intrinsic evidence includes the claims themselves, the specification, and the prosecution history. *See Phillips*, 415 F.3d at 1314; C.R. Bard, Inc., 388 F.3d at 861. Courts give claim terms their ordinary and accustomed meaning as understood by one of ordinary skill in the art at the time of the invention in the context of the entire patent. Phillips, 415 F.3d at 1312-13; Alloc, Inc. v. Int'l Trade Comm'n, 342 F.3d 1361, 1368 (Fed.Cir.2003).

The claims themselves provide substantial guidance in determining the meaning of particular claim terms. Phillips, 415 F.3d at 1314. First, a term's context in the asserted claim can be very instructive. *Id.* Other asserted or unasserted claims can also aid in determining the claim's meaning because claim terms are typically used consistently throughout the patent. *Id.* Differences among the claim terms can also assist in understanding a term's meaning. *Id.* For example, when a dependent claim adds a limitation to an independent claim, it is presumed that the independent claim does not include the limitation. *Id.* at 1314-15.

"[C]laims 'must be read in view of the specification, of which they are a part.'" *Id.* (quoting Markman v. Westview Instruments, Inc., 52 F.3d 967, 979 (Fed.Cir.1995) (en banc)). "[T]he specification 'is always highly relevant to the claim construction analysis. Usually, it is dispositive; it is the single best guide to the meaning of a disputed term.'" *Id.* (quoting Vitronics Corp. v. Conceptronic, Inc., 90 F.3d 1576, 1582 (Fed.Cir.1996)); Teleflex, Inc. v. Ficosa N. Am. Corp., 299 F.3d 1313, 1325 (Fed.Cir.2002). This is true because a patentee may define his own terms, give a claim term a different meaning than the term would otherwise possess, or disclaim or disavow the claim scope. Phillips, 415 F.3d at 1316. In these situations, the inventor's lexicography governs. *Id.* Also, the specification may resolve ambiguous claim terms "where the ordinary and accustomed meaning of the words used in the claims lack sufficient clarity to permit the scope of the claim to be ascertained from the words alone." Teleflex, Inc., 299 F.3d at 1325. But, "[a]lthough the specification may aid the court in interpreting the meaning of disputed claim language, particular embodiments and examples appearing in the specification will not generally be read into the claims.'" Comark Commc'ns, Inc. v. Harris Corp., 156 F.3d 1182, 1187 (Fed.Cir.1998) (quoting Constant v.

Advanced Micro-Devices, Inc., 848 F.2d 1560, 1571 (Fed.Cir.1988)); *see also* Phillips, 415 F.3d at 1323. The prosecution history is another tool to supply the proper context for claim construction because a patent applicant may also define a term in prosecuting the patent. Home Diagnostics, Inc., v. Lifescan, Inc., 381 F.3d 1352, 1356 (Fed.Cir.2004) ("As in the case of the specification, a patent applicant may define a term in prosecuting a patent.").

Although extrinsic evidence can be useful, it is "less significant than the intrinsic record in determining the legally operative meaning of claim language." Phillips, 415 F.3d at 1317 (quoting C.R. Bard, Inc., 388 F.3d at 862). Technical dictionaries and treatises may help a court understand the underlying technology and the manner in which one skilled in the art might use claim terms, but technical dictionaries and treatises may provide definitions that are too broad or may not be indicative of how the term is used in the patent. *Id.* at 1318. Similarly, expert testimony may aid a court in understanding the underlying technology and determining the particular meaning of a term in the pertinent field, but an expert's conclusory, unsupported assertions as to a term's definition is entirely unhelpful to a court. *Id.* Generally, extrinsic evidence is "less reliable than the patent and its prosecution history in determining how to read claim terms." *Id.*

CLAIM TERMS

Effective Cutting Face Backrake Angle(s)

Claims in the '249 and '715 Patents contain the terms "effective cutting face backrake angle(s)" and "negative effective cutting face backrake angle"; claims in the '631 Patent contain the term "effective backrake angle." Baker Hughes contends these terms should be construed to mean:

the net overall backrake angle of the cutting face as measured backward from a line placed perpendicular (at a ninety degree angle) to the formation to be cut by the cutter in the intended direction of drill bit rotation, and as determined by a combination of any one or more of the cutter backrake angle, the chamfer backrake angle, the chamfer angle, chamfer width, and depth of cut.

ReedHycalog contends the terms mean "the negative angle (expressed as a positive number) between a line oriented perpendicular to the subterranean formation to be engaged by a cutter and the portion(s) of the cutting face of the cutter that engages the formation during drilling, measured in the direction of intended bit rotation." At the claim construction hearing, ReedHycalog stated it was willing to replace "negative angle (expressed as a positive number)" with the term "angle."

The '249, '715, and '631 Patents specifications give little guidance. Fig. 11 of the '249 Patent, which is substantially identical to Fig. 11 in the '715 Patent, is helpful to determine the terms' meaning. With reference to Fig. 11 of the '249 Patent, annotated and depicted in Appendix C, the specifications appear to communicate the following. FN1

FN1. Appendix C contains the Court's annotations of certain figures. Given the nature of these patents, the figures are extremely helpful in discussing some of the concepts presented in this Opinion.

At a shallow depth of cut ("DOC 1") where only the chamfers engage the formation, the effective cutting face backrake angle is the chamfer backrake angle, shown in Fig. 11 as $(\beta)_1$. '249 Patent col. 7:3-13; '715 Patent col. 10:39-49. At a deeper depth of cut ("DOC2") where the cutting face engages the formation, the

effective cutting face backrake angle is $(\beta)_2$, which in Fig. 11 appears to be the angle between the portion of the cutting face that engages the formation and a line perpendicular to the formation. '249 Patent col. 7:13-21, col. 7:48-56; '715 Patent col. 10:49-57, col. 11:16-21. It also appears that at some depth of cut deeper than DOC2, the effective cutting face backrake angle will converge to the cutter backrake angle (δ), assuming the cutting face is oriented substantially perpendicular to the cutter's longitudinal axis. '249 Patent col. 7:48-56; '715 Patent col. 11:49-57, col. 11:16-21. Therefore, it appears $(\beta)_1$ and (δ) are, respectively, the upper and lower bounds of the effective cutting face backrake angle, and $(\beta)_2$ lies somewhere between.

The Court agrees with ReedHycalog's modified construction. Thus, "effective cutting face backrake angle(s)," "negative effective cutting face backrake angle," and "effective backrake angle" mean "angle(s) between a line oriented perpendicular to the subterranean formation to be engaged by a cutter and the portion(s) of the cutting face of the cutter that engages the formation during drilling, measured in the direction of intended bit rotation." FN2 At shallow depths-of-cut where only the chamfer engages the formation (DOC 1), this angle is the chamfer backrake angle. At some depth of cut, the effective cutting face backrake angle will converge to the cutter backrake angle, assuming the cutting face is oriented substantially perpendicular to the cutter's longitudinal axis.

FN2. Ref. No. 3 of Appendix B contains the disputed terms and their constructions.

Exhibit Substantially Larger Effective Cutting Face Backrake Angles

Claims in the '249 and '715 Patents require the drill bit to exhibit "substantially larger," "substantially more negative," or "substantially less aggressive" effective cutting face backrake angles. '249 Patent col. 8:60-61; '715 Patent col. 20:25-27, col. 25:4-6. Baker Hughes argues these terms mean "that each effective cutting face backrake angle is to a great extent larger as measured backward from a line placed perpendicular (at a ninety degree angle) to the formation to be cut by the cutter in the intended direction of drill bit rotation." ReedHycalog contends these terms do not require construction.

The dispute centers on the construction of "substantially." A lay jury will understand what "substantially" means, and therefore the term does not require construction.FN3

FN3. Ref., No. 4 of Appendix B contains the disputed terms and their constructions.

Chamfer Backrake Angle

The term "chamfer backrake angle" appears in claims in the '715 Patent. Baker Hughes contends "chamfer backrake angle" means:

The angle of the beveled area or cut off edge at the periphery of the central portion of the cutting face as measured backward from a line placed perpendicular (at a ninety degree angle) to the formation to be cut by the cutter in the intended direction of drill bit rotation.

ReedHycalog contends "chamfer backrake angle" means "the negative angle (expressed as a positive number), between a line oriented perpendicular to the subterranean formation to be engaged by a cutter and

the portion(s) of the chamfer that engages the formation during drilling, measured in the direction of intended bit rotation." Baker Hughes's construction defines "chamfer" and combines that definition with its construction of "effective cutting face backrake angle." ReedHycalog's construction does not define chamfer but modifies its construction of "effective cutting face backrake angle" to apply to the "chamfer." Thus, the parties' dispute centers on whether "chamfer" needs construction.

A lay jury can understand "chamfer" and does not need it defined. The '715 Patent figures also clearly show the chamfer, and a further definition would not help the jury. Fig. 11 of the '715 Patent, annotated and displayed in Appendix C, shows the chamfer backrake angle, labeled $(\beta)_1$. '715 Patent col. 10:36-37 (defining "chamfer backrake angle" as $(\beta)_1$).

As shown, the chamfer backrake angle is the angle between the portion of the chamfer that engages the formation and a line perpendicular to the formation. ReedHycalog's construction is correct, and the Court adopts a modified construction. Thus, "chamfer backrake angle" means "the angle between a line oriented perpendicular to the subterranean formation to be engaged by a cutter and the portion(s) of the chamfer that engages the formation during drilling, measured in the direction of intended bit rotation, labeled $(\beta)_1$ in Fig. 11 of the '715 Patent." FN4

FN4. Ref. No. 14 of Appendix B contains the disputed term "chamfer backrake angle" and its construction.

Profile

The '715 Patent claims contain the term "profile." Baker Hughes contends "profile" means "the shape or outline of the leading end of the bit as viewed in cross section." ReedHycalog contends "profile" means "radial cross section of the bit, defined by the blades of the bit." The parties dispute whether the drill bit profile is a cross section of the leading end of the drill bit or is a cross section of only the drill bit blades.

The '715 Patent specification states "[b]it profile 224 of bit face 204 as defined by the blades 206 is illustrated in FIG. 10" '715 Patent col. 9:29-30. Fig. 10, annotated and shown in Appendix C, illustrates the profile of the drill bit. Thus, "profile" means "radial cross-section or outline of the bit, defined by the blades of the bit, labeled 224 in Fig. 10 of the '715 Patent." FN5

FN5. Ref. No. 15 of Appendix B contains the disputed term "profile" and its construction.

Cone, Nose, Flank, and Shoulder Region

Claims in the '249, '715, and '631 Patents contain the terms "cone" or "cone region," "nose" or "nose region," "flank" or "flank region," and "shoulder region." The parties dispute whether these regions extend around the circumference of the drill bit face or are limited to the blades of the drill bit face. The parties further dispute the construction of these regions with respect to each other.

Whether the Regions Extend Around the Circumference of the Drill Bit Face

Baker Hughes contends "cone," or "cone region," means "the area or region extending around the entire circumference on the drill bit face and which is located radially closest to the centerline or longitudinal axis

of the drill bit body (and which is shaped more or less like an inverted cone)." Baker Hughes proposes similar constructions for the other claim terms and contends these regions extend around the entire circumference of the bit face.

ReedHycalog contends "cone," or "cone region," means the "region, defined by the blades of the bit, radially between the nose and the center longitudinal axis of the bit." ReedHycalog proposes similar constructions for the other claim terms and claims these regions are defined by the drill bit blades and do not extend around the entire circumference of the bit face.

The specifications of the '249, '715, and '631 Patents support a construction that limits the "cone," "nose," "flank," and "shoulder" regions to the blades. The '249 and '715 Patents refer to the "cone," "nose," "flank," and "shoulder" regions as being regions within the bit profile. '249 Patent col. 5:66-col. 6:1; '715 Patent col. 9:34-39. As the blades define the bit profile, and each of these regions are located in the bit profile, the blades likewise define the "cone," "nose," "flank," and "shoulder" regions.

Second, figures in the '249, '715, and '631 Patents confirm that these regions are limited to the area defined by the drill bit blades. Fig. 10 of the '249 and '715 Patents, displayed in Appendix C and annotated, shows the "cone," "nose," "flank," and "shoulder" regions along the bit profile. Fig. 13 of the '715 Patent, a quarter-sectional side view of the three-region embodiment of the claimed drill bit, similarly shows the disputed regions along the bit profile. '715 Patent Fig. 13. Figs. 14A and 14B of the '631 Patent, reproduced in Appendix C and annotated, show the "cone," "nose," "flank," and "shoulder" regions on the blades of the drill bit. While Fig. 14C of the '631 Patent, annotated and shown in Appendix C, tends to support Baker Hughes's contention that the "cone region" extends circumferentially around the drill bit, the above intrinsic evidence more clearly shows that this region, in addition to the "nose," "flank," and "shoulder" regions, is limited to the drill bit blades. Thus, the Court construes these terms to only extend on the blades of the drill bit.

Radial Location of Each Region With Regard to Other Regions

Baker Hughes and ReedHycalog additionally dispute the definition of each region on the drill bit in relation to the other regions. In short, Baker Hughes defines "cone" as "... located radially closest to the centerline or longitudinal axis of the drill bit body ..." and subsequently defines "nose" as the area or region radially between the cone and the "flank," which includes the leading most point on the drill bit body. Similarly, Baker Hughes defines "flank" as the area or region radially between the "nose" and the "shoulder" or "gage," and "shoulder region" as the area or region radially between the "flank" and the "gage," although in a given drill bit, the "flank" and "shoulder" regions may be the same part of the bit.

ReedHycalog's constructions are similar, except that ReedHycalog starts with the "nose," which it construes as "extending radially and proximately about the leading-most point." ReedHycalog defines "cone" as the region radially between the "nose" and the longitudinal axis of the drill bit body, "flank" as the area or region radially between the "nose" and the "shoulder region," and the "shoulder region" as radially proximate the "gage."

Cone

The '715 Patent, in the Brief Summary of the Invention, describes "cone region" as the "radially innermost portion." '715 Patent, col. 3:14-15, 39-40. Similarly, the '631 Patent, in the Brief Summary of the Invention, describes the "cone" as "the region of the bit proximate the centerline of the bit." '631 Patent, col. 5:37-43.

The patents do not disclose any area or region radially between the "cone" and the "nose."

The Court adopts a modified construction of "cone" and "cone region" to comport with the specifications. Thus, "cone," or "cone region," means "radially innermost region, defined by the blades of the bit, located radially between the nose and the center longitudinal axis of the bit, labeled 230 in Fig. 10 of the '249 and '715 Patents." FN6

FN6. Ref. No. 5 of Appendix B contains the disputed terms and their construction.

Nose

Similarly, there is little difference between the parties' constructions of "nose" and "nose region." The '249, '715, and '631 Patents specifications refer to the "nose," or "nose region," as part of "an outer region," as a "radially intermediate portion" of the bit face between the "cone" and the "flank" and "shoulder" regions, or as "more radially distant" from the centerline than the "cone." '249 Patent col. 8:14-18; '715 Patent col. 3:11-18, 36-45; '631 Patent col. 4:37-43, col. 5:37-43. This language in the specifications supports Baker Hughes's contention that the "nose," or "nose region," is located radially between the "cone" the "flank" regions. Further, as the parties agree, all embodiments of the invention show the leading-most point of the bit within the "nose" or "nose region." '249 Patent Fig. 10; '715 Patent Figs. 10, 13; '631 Patent Figs. 15A, 15, 16, 17.

The Court slightly modifies Baker Hughes' construction. Thus, "nose," or "nose region," means "region, defined by the blades of the bit, located radially between the cone and flank regions, and includes the leading-most point on the blades, labeled 232 in Fig. 10 of the '249 and '715 Patents." FN7

FN7. Ref. No. 6 of Appendix B contains the disputed terms and their construction.

Flank

The parties propose nearly identical constructions of "flank" and "flank region." Baker Hughes contends the "flank" is radially less distant than the shoulder or gage regions. ReedHycalog contends the "flank" is located radially between the "nose" and "shoulder region."

The '631 Patent specification states that, as understood in the art, the "shoulder region" will often incorporate the "flank region." '631 Patent col. 19:60-66. The '715 and '631 Patents, in their Summary of the Invention sections, also describe the present invention in terms of cutters located in the "nose," "shoulder," and "cone" regions without mention of the "flank" region. '715 Patent col. 5:65-col. 6:1-6; '631 Patent col. 5:37-43. However, the '249, '715, and '631 Patents only disclose embodiments of the invention that include a "shoulder" or "shoulder region" radially between a separate, disjoint "flank" region and the "gage." '249 Patent Fig. 10, col. 5:59-col. 6:2; '715 Patent, Figs. 10, 13, col. 9:35-39, col. 12:55-63; '631 Patent, Figs. 14A, 15A, 15C, 16, 17, col. 19:60-65.

Despite the more limited embodiments, the language in the '631 Patent shows that whether the "flank" is its own region or incorporated within the "shoulder region," the "flank" region is always radially between the "nose" and the "gage" of the drill bit. The '249, '715, and '631 Patent disclosures are consistent with this result, even if the embodiments only show the "flank" and "shoulder" regions as separate and adjacent.

Accordingly, "flank" and "flank region" mean "region defined by the blades of the bit, located radially between the nose and the gage regions, labeled 234 in Fig. 10 of the '249 and '715 Patents." FN8

FN8. Ref. No. 7 of Appendix B contains the disputed terms and their construction.

Shoulder Region

The '631 Patent claims a "shoulder region." Baker Hughes contends this region is the region "radially more distant from the centerline or longitudinal axis of the drill bit body than the flank region, but which is radially less distant from that centerline than the gage region." Further, Baker Hughes states "[i]n a given drill bit, the flank and shoulder regions may be the same." ReedHycalog contends the "shoulder region" is "radially proximate the gage."

As discussed above, the "shoulder region" may incorporate the "flank region." In this configuration, the "shoulder region" is radially between the "nose" and "gage" regions. If the "shoulder region" does not incorporate the "flank region," the "shoulder region" is radially between the "flank" and "gage" regions. '249 Patent Fig. 10, col. 5:59-col. 6:2; '715 Patent, Figs. 10, 13, col. 9:35-39, col. 12:55-63; '631 Patent, Figs. 14A, 15A, 15C, 16, 17, col. 19:60-65. Therefore, the construction of "shoulder region" must comport with both embodiments.

The Court agrees with Baker Hughes but modifies its construction. "Shoulder region" means "region defined by the blades of the bit, located radially between the nose and gage regions if the shoulder region is incorporated with the flank region, and located radially between the flank and gage regions if the flank region exists separately, labeled 316 in Fig. 16 of the '631 Patent." FN9

FN9. Ref. No. 9 of Appendix B contains the disputed term "shoulder region" and its construction.

Gage

Similar to the above dispute, the parties disagree on whether the "gage" or "gage region" of the drill bit extends around the entire circumference of the drill bit or only encompasses the outermost radius of the bit. Baker Hughes contends "gage," or "gage region," means "area or region extending around the entire circumference on the drill bit and which is located at the maximum or outermost diameter of the drill bit body." ReedHycalog contends "gage" means "the outermost radius of the bit" and "gage region" means "region at the outermost radius of the bit."

Figures in the '249, '715, and '631 Patents distinguish between the "gage," or "gage region," and the junk slots. In particular, Fig. 7 of the '249 and '715 Patents, reproduced in Appendix C and annotated, shows the "gage" is disjoint from the junk slots and fluid courses on drill bit. In addition, Fig. 14A of the '631 Patent, shown in Appendix C and annotated, shows the "gage region" distinct from the junk slots and fluid courses and depicts the "gage region" as the region at the outermost radius of the bit. Thus, "gage" means "the outermost radius of the bit, labeled 207 in Fig. 7 of the '249 and '715 Patents" and "gage region" means "region at the outermost radius of the bit, labeled 322 in Fig. 14A of the '631 Patent." FN10

FN10. Ref. No. 8 of Appendix B contains the disputed terms and their construction.

First Region, Second Region, and Third Region Radially Intermediate the First and Second Regions

Claims in the '249, '715, and '631 Patents contain the terms "first region" and "second region." Claims in the '715 Patent contain the term "third region," which is "radially intermediate the first and second regions." The parties disagree whether these regions extend around the entire circumference of the drill bit face or are limited to the blades of the bit. Further, the parties dispute whether these regions are limited to certain areas of the bit face.

Whether Regions Extend Around the Circumference of the Drill Bit Face

Baker Hughes contends "first region," "second region," and "third region" extend circumferentially around the bit face. It argues these regions are naturally circumferential. ReedHycalog contends these terms do not need construction and argues these regions are limited to the blades of the bit.

The claims and the specifications do not indicate that these regions extend around the circumference of the drill bit face. The claims of the '249 and '715 Patents describe the "first," "second," and "third" regions in terms of the cutters located in each region and cutter aggressiveness. *E.g.* '249 Patent col. 8:46-53 ("What is claimed is: a rotary drag bit for drilling a subterranean formation, comprising: ... a plurality of cutters secured to the bit body in the first and second regions"); '715 Patent col. 20:6-17 ("What is claimed is: a rotary drag bit for drilling a subterranean formation, comprising: ... a plurality of cutters located on the bit body in the first, second, and third regions"); '631 Patent col. 35:63-col. 26:4 (claiming "a rotary drag bit for drilling subterranean formations comprising: ... a plurality of cutters secured on the bit body in the first and second regions").

Similarly, the specifications discuss the "first," "second," and "third" regions with regard to the characteristics of cutters located in those regions. In particular, the '249 Patent states:

The cutters themselves, as disposed in first region 226, are backraked at 20 (deg.) to the bit profile at each respective cutter location, thus providing chamfers 124 with a 65 (deg.) backrake.... Cutters ... disposed in second region 228 are themselves backraked at 15 (deg.) on nose 232, providing a 60 (deg.) chamfer backrake, while cutter backrake is further reduced to 10 (deg.) at the flank 234, shoulder 236 and on the gage 207 of bit 200, resulting in a 55 (deg.) chamfer backrake.

'249 Patent col. 6:10-23.

Likewise, the '715 Patent specification describes the regions in the three-region embodiment in terms of the cutters located in those regions:

[A]t least one of the plurality of the cutters located in first region ... exhibit respective effective cutting face backrake angles which may be characterized as being relatively nonaggressive In contrast to the generally less aggressive cutters positioned generally in first region ..., at least one of the plurality of the cutters, and preferably at least a majority of the cutters located in second region ..., exhibit respective effective cutting face backrake angles which may be characterized as being relatively aggressive [T]hird region 228' is provided with at least one cutter ... exhibiting respective effective cutting face backrake angles which may be characterized as being intermediately aggressive in comparison to the cutters positioned generally in first region 226 and second region 228.

'715 Patent col. 12:44-col. 13:9.

The '249, '715, and '631 Patents only disclose drill bits with cutters located on the drill bit blades. While the "first," "second," and "third" regions could encompass other areas on drill bit, such a construction would make little sense, as the patents only use the first, second, and third regions to identify cutter attributes of cutters in each region, and such cutters are located on the drill bit blades.

Further, figures in the '249 and '715 Patents support limiting the "first," "second," and "third" regions to the area defined by the drill bit blades. Fig. 10 of the '249 and '715 Patents, which depicts the two-region embodiment, shows the "first" and "second" regions located along the profile of the drill bit. The bit profile, as discussed above, is defined by the drill bit blades. Thus, the "first" and "second" regions extend along the blades.

Similarly, Fig. 13 of the '715 Patent, which depicts the three-region embodiment, shows the "first," "second," and "third" regions along the bit profile, which is defined by the drill bit blades. Finally, Fig. 12 of the '715 Patent, an oblique face view of the three-region embodiment, shows the three regions along the blade of the bit. Thus, "first region," "second region," and "third region" extend along the blades and do not extend around the circumference of the bit face.

Whether Regions Are Limited to Certain Areas on Drill Bit Face

Baker Hughes contends the "first region" is located "generally on the center of the bit face or on leading end of the bit radially closest to the centerline or longitudinal axis of the drill bit body." It contends the "second region" is located "generally radially distant or remote from the centerline or longitudinal axis of the drill bit body between the first region and the outer region at the maximum or outermost diameter of the face or leading end of the bit." Lastly, Baker Hughes contends the "third region," if it is present, is located "generally radially in between the first and second regions." ReedHycalog argues these terms do not need construction and the regions are not limited to specific areas on the bit face.

The '249 and '715 Patents disclose the "first region" closest to the center, a "second region" radially more distant than the first region, and a "third region," if present, located radially between the first and second regions. *E.g.* '249 Patent Fig. 10; '715 Patent Figs. 10, 12, 13.

The '631 Patent only mentions the regions in the claim language and uses the regions to distinguish the cutters located in each region. '631 Patent col. 26:3-13, col. 26:16-17. The '631 Patent only discloses cutters secured on the drill bit blades, one cutter per radial location. *Id.* at Figs. 1, 2, 2A, 14A, 15A, 15B. As a result, one region is radially closer to the centerline of the drill bit than the other region, and the label of each region only matters with regard to the characteristics of the cutters located in each region. It is consistent with the dependant claims of the '631 Patent and the '249 and '715 Patents specifications to label the inner region as "first region" and the outer region as "second region." *Id.* at col. 36:13-50; '249 Patent Fig. 10; '715 Patent Figs. 10, 12, 13.

Therefore, "first region" means "area or region defined by the blades of the bit, located generally on the center of the bit face or on the leading end of the bit radially closest to the centerline or longitudinal axis of the drill bit body, labeled 226 in Fig. 10 of the '249 Patent and Figs. 10, 12, and 13 of the '715 Patent." FN11 "Second region" means "area or region defined by the blades of the bit, located generally radially distant or

remote from the centerline or longitudinal axis of the drill bit body between the first region and the outer region at the maximum or outermost diameter of the face or leading end of the bit, labeled 228 in Fig. 10 of the '249 Patent and Figs. 10, 12, and 13 of the '715 Patent." FN12 "Third region" means "area or region, if any, defined by the blades of the bit, located generally radially in between the first and second regions, labeled 226' in Figs. 12 and 13 of the '715 Patent." FN13

FN11. Ref. No. 10 of Appendix B contains the disputed term "first region" and its construction.

FN12. Ref. No. 11 of Appendix B contains the disputed term "second region" and its construction.

FN13. Ref. No. 12 of Appendix B contains the disputed term "third region" and its construction.

However, these constructions do not connect "first region," "second region," or "third region" to the terms "cone," "nose," "flank," "shoulder," or "gage." Courts presume a difference in meaning and scope when a patentee uses different phrases in separate claims. *Phillips*, 415 F.3d at 1314-15. Where a party seeks to limit an independent claim with language that appears in a dependant claim, the presumption is especially strong. *Liebel-Flarsheim Co. v. Medrad, Inc.*, 358 F.3d 898, 910 (Fed.Cir.2004). However, the doctrine of claim differentiation is not a "hard and fast rule," and courts cannot use the doctrine to broaden claims beyond their correct scope, determined in light of the intrinsic record and relevant extrinsic evidence. *Seachange Int'l, Inc. v. C-COR, Inc.*, 413 F.3d 1361, 1369 (Fed.Cir.2005); *see also Phillips*, 415 F.3d at 1312-15.

The independent claims in the '249 and '715 Patents do not limit any of the regions to a particular location on the bit face. Only the dependant claims define the first, second, and third regions of the bit face with the terms "cone," "nose," "flank," and "gage." '249 Patent col. 8:64-67 (claiming rotary drag bit "wherein the first region lies within a cone ... and the second region extends at least over a nose and flank"); '715 Patent col. 20:29-33 (claiming a rotary drag bit "wherein the first region lies within a cone ..., the second region extends over at least a flank ..., and the third region extends over at least a nose"); '249 Patent col. 9:1-2 (claiming a rotary drag bit "wherein the second region extends to a gage of the bit body"); '715 Patent col. 20:34-35 (claiming a rotary drag bit "wherein the second region extends to the gage of the bit body"); '631 Patent col. 36:25-29 (claiming a rotary drag bit "wherein the first region comprises a cone region and the second region comprises at least one of the group consisting of a nose region, a shoulder region, and a flank region"). Though these terms do not explicitly include the "shoulder region," the "second region" necessarily includes the "shoulder" if the "second region" extends to the "gage" of the drill bit face. *E.g.* '249 Patent Fig. 10; '715 Patent Figs. 10, 13.

Constructions of "first region," "second region," and "third region" that include the terms "cone," "nose," "flank," "shoulder," or "gage" would render dependant claims 2 and 3 of the '249 Patent redundant with independent claim 1 of the '249 Patent, would render dependant claims 2 and 3 of the '715 Patent redundant with independent claim 1 of the '249 Patent, and would render dependant claim 68 of the '631 Patent redundant with independent claim 64 of the '631 Patent. Therefore, it is presumed "first region," "second region," and "third region" do not include "cone," "nose," "flank," "shoulder," or "gage" limitations.

The '249 and '715 Patents specifications state "first region" "may be said to comprise the cone 230," "second

region" "may be said to comprise nose 232, flank 234, and generally includes shoulder 236 of profile 224," and "third region" "generally corresponds to nose 232." '249 Patent col. 5:65-col. 6:2; '715 Patent col. 9:35-39, col. 13:2-5. This permissive language is not sufficient to rebut the presumption that "first region," "second region," and "third region" are not so limited. *See Gillette Co. v. Energizer Holdings, Inc.*, 405 F.3d 1367, 1371 (Fed.Cir.2005) (transition "comprising" is presumptively not limited to recited elements, and can include additional elements not recited).

In addition, any definitions of "first region," "second region," and "third region" that include the terms "cone," "nose," "flank," and "shoulder" either exclude an embodiment of the inventions or may confuse a jury. In the two-region embodiment, the "first region" contains the "cone" and the "second region" contains the "nose," "flank," and "shoulder" regions of the bit profile. '249 Patent col. 5:65-col. 6:2; '715 Patent col. 9:35-39. In the three-region embodiment, the "second region" contains the "flank" and "shoulder" regions, while the "third region" contains the "nose." '715 Patent Fig. 13, col. 12:55-col. 13:9. An accurate construction of "second region" that contains "nose," "shoulder," or "flank" would therefore take into account both embodiments, which would be unnecessarily wordy and confusing.

Radially Intermediate the First and Second Regions

Baker Hughes contends "radially intermediate the first and second regions" means "located radially (from the longitudinal axis of the drill bit body) between the first and second regions." ReedHycalog argues this term does not require construction. The Court agrees with ReedHycalog. The term does not require construction. A lay jury will be able to understand the drill bit location of a "third region, radially intermediate the first and second regions." FN14

FN14. Ref. No. 13 of Appendix B contains the disputed term "radially intermediate the first and second regions and its construction.

Conventional Rotary Drag Bit

Claims in the '715 Patent contain the term "conventional rotary drag bit." Baker Hughes argues this term does not need construction. ReedHycalog contends the Court should construe this term to mean "a rotary drag bit having either highly backraked cutters distributed over generally the entire face of the bit or having more aggressive cutters positioned in the cone region of the bit and relative less aggressive cutters positioned toward the gage region of the bit."

The Court agrees with Baker Hughes. The term "conventional rotary drag bit" does not require construction.FN15

FN15. Ref. No. 17 of Appendix B contains the disputed term "conventional rotary drag bit" and its construction.

Torque

Claims in the '715 Patent contain the terms "torque-on-bit" and "torque response." Baker Hughes contends "torque-on-bit" and "torque response" mean "forces responsive or reactive to drill bit rotation (which typically is a force or are forces in a direction other than the direction of drill bit rotation)." ReedHycalog

argues "torque-on-bit" and "torque response" mean "resistance to rotation." The dispute centers on whether torque is limited to forces opposite the direction of drill bit rotation. ReedHycalog's definition limits torque to forces opposite drill bit rotation; Baker Hughes's construction is not so limited.

There is no support to limit "torque-on-bit" or "torque response" to the torque in the direction opposite of drill bit rotation. Thus, the terms are not so limited. Further, a lay jury will understand the term "torque," and therefore the terms "torque-on-bit" and "torque response" require no construction.FN16

FN16. Ref. Nos. 18 and 19 of Appendix B contains the disputed terms and their constructions.

Similarly, the preamble of claim 33 of the '631 Patent claims "a method of drilling ... without generating an excessive amount of torque-on-bit." A lay jury will understand the term "excessive," and therefore that term does not require construction.FN17

FN17. Ref. No. 34 of Appendix B contains the disputed term "without generating an excessive amount of torque-on-bit" and its construction.

Radial Location of Superabrasive Cutters and Depth of Cut Control Features

Claims in the '0 Patent discuss the radial location of the superabrasive cutters and depth of cut control features. The parties dispute whether the claims require the superabrasive cutters and depth of cut control features to be centered.

At a Radius

Claims in the '0 Patent require at least one superabrasive cutter to be secured to the bit body "at a radius from the centerline of the bit body" or "positioned at a radius from the centerline." Baker Hughes and ReedHycalog dispute whether this claim term includes a "centered" limitation wherein the superabrasive cutter is centered at a distance from the radius.

The "centered" limitation is not present in the claim language of the '930 Patent, nor is it supported by the specification. Thus, these terms mean "at a distance perpendicular (at a ninety degree angle) from the centerline of the drill bit body ('the radius')." FN18

FN18. Ref., No. 21 of Appendix B contains the disputed terms and their constructions.

Disposed Substantially at the Radius

The '0 Patent claims also require exterior structures, features, or bearing segments "disposed substantially at the radius" of their associated superabrasive cutters. Baker Hughes and ReedHycalog dispute whether these terms require the exterior structures, features, or bearing segments to be centered at the same radius as their associated superabrasive cutters. ReedHycalog contends the patents require the abovementioned centered placement of these structures; Baker Hughes argues the patents are not so limited.

The '0 Patent claims do not contain a "centered" limitation. Despite this claim language, ReedHycalog

points to Figs. 1, 2, and 2A of the '0 Patent and the accompanying description to support its construction.

However, the '0 Patent figures do not delineate the centers of the superabrasive cutters or the exterior structures, features, or bearing segments. The figures do not indicate that the centers of the exterior structures, features, or bearing segments lie along the same radius as the centers of the associated superabrasive cutters. The supporting text in the specification also does not describe or impose any requirement that the exterior structures, features, or bearing segments be centered at the same radius as the center of their associated superabrasive cutters.

ReedHycalog further contends Baker Hughes, to overcome a 35 U.S.C. s. 102(b) rejection by the Examiner, narrowed its claim language to require the exterior structures, features, or bearing segments to be "centered" at the same radius as the center of their associated superabrasive cutters. During prosecution of the '0 Patent, the Examiner rejected the claim that contained the "disposed substantially at the radius" language under 35 U.S.C. s. 102(b) in light of U.S. Pat. No. 4,554,986 (the "Jones Patent"). As Baker Hughes argued when it amended the claims, the Jones Patent discloses bearing structures that extend from center outward and not structures placed at substantially the same radius as an associated superabrasive cutter. Nowhere in the claim amendment did Baker Hughes mention a centered limitation, nor is one necessarily implied to distinguish the claims in the '0 Patent from the Jones Patent. Thus, the prosecution history of the '0 Patent does not support ReedHycalog's contention that the exterior structures, features, or bearing segments must be centered at the same radius as their associated superabrasive cutters.

For the abovementioned reasons, the claim term does not include a "centered" limitation. Therefore, "disposed substantially at the radius" means "located close to the radius." FN19

FN19. Ref. No. 22 of Appendix B contains the disputed term "disposed substantially at the radius" and its construction.

Rotational Location of Depth of Cut Control Features

The '0 Patent claims include the terms "exterior structure," "exterior surface," "exterior feature," "bearing segments," "bearing area," and "at least one feature." ReedHycalog contends the claims should be limited to structures that rotationally precede the associated cutters. Baker Hughes contends the '0 Patent is not limited to structures that rotationally precede the associated cutters, as the claims of the '0 Patent do not contain the term "rotationally preceding."

Baker Hughes argues the doctrine of claim differentiation indicates there is no limit on the rotational placement of the bearing structures in independent claims. As stated above, courts presume a difference in meaning and scope when a patentee uses different phrases in separate claims. Phillips, 415 F.3d at 1314-15. The presumption is especially strong when a party seeks to limit an independent claim with language that appears in a dependant claim. Liebel-Flarsheim Co., 358 F.3d at 910. However, the doctrine of claim differentiation is not a "hard and fast rule," and courts cannot use the doctrine to broaden claims beyond their correct scope, determined in light of the intrinsic record and relevant extrinsic evidence. Seachange Int'l, Inc., 413 F.3d at 1369; *see also* Phillips, 415 F.3d at 1312-15.

Claims 1 and 17 of the '0 Patent claim an "exterior structure" or a "feature" to limit the depth of cut of at least one superabrasive cutter. ' 930 Patent col. 15:42-48, col. 16:64-col. 17:2. Claim 2 requires the "exterior

structure" claimed in claim 1 to comprise "a plurality of bearing segments." Id. at col. 15:49-59. Claim 18 requires at least one "feature" claimed in claim 17 to comprise "a plurality of bearing segments." Id. at col. 17:3-13. Claims 3 and 19 require at least some of the "bearing segments" claimed in claims 2 and 18, respectively, to rotationally lead, in the direction of bit rotation, one superabrasive cutter of the plurality of superabrasive cutters. Id. at col. 15:60-64, col. 17:14-17.

ReedHycalog's construction renders claim 3 redundant with claim 1 and claim 19 redundant with claim 17. Therefore, ReedHycalog's construction raises the presumption that the "bearing segments" claimed in claims 2 and 18, and the associated "exterior structures" and "feature" claimed in claims 1 and 17, are not limited to structures that rotationally lead the cutters. The presumption of claim differentiation also applies to similar terms in claims 37, 42, 44, and 49 ("exterior feature"), claim 47 ("exterior surface feature"), and claims 52, 53, 55, and 57 ("bearing area"), as these structures function almost identically to the "bearing segments" in claims 3 and 19. Id. at col. 15:49-59 (claiming "a plurality of bearing segments having bearing surfaces ... wherein a combination of bearing surfaces of the plurality exhibits sufficient surface area"); id. at col. 17:3-13 (substantially similar use of "bearing segments" and "bearing surfaces"); id. at col. 18:49-64 (claiming "at least one exterior feature ... sufficient to support the bit thereon under a weight on bit at least as great as the total weight on bit without failure of the at least one formation"); id. at col. 19:29-43 (substantially similar use of "at least one exterior feature"); id. at col. 20:8-21 (claiming "at least one exterior surface feature ... sufficient to preclude plastic failure of the at least one formation under at least the total weight on bit"); id. at col. 20:53-63 (claiming "a bearing area ... to distribute the excess weight on bit sufficient to achieve a unit load by the bearing surface area on the formation less than a compressive strength of the formation"); id. at col. 21:11-23 (substantially similar use of "bearing area"); id. at col. 20:64-col. 21:6 (claiming "a bearing area ... sufficient to support the drill bit on the subterranean formation without failure thereof"); id. at col. 21:28-22:4 (substantially similar use of "bearing area").

The '0 Patent specification rebuts the presumption of claim differentiation. The specification describes Figs. 10A, 10B and 12, which depict bearing surfaces that rotationally lead their associative cutters, as "according to the present invention." Id. at Figs. 10A, 10B, 12, col. 4:49-51, col. 4:55-59. In total, the '0 Patent only discloses embodiments where the depth of cut control structures rotationally lead their associative cutters. Id. at Figs. 1, 10A, 10B, 12.

The specification also distinguishes between the prior art and the present invention in terms of the rotational location of the depth of cut limiting structures. The specification describes Fig. 4 as a comparison between prior art following structures and leading structures "according to the present invention." Id. at Fig. 4, col. 4:26-30. The specification further distinguishes the rotationally leading placement "according to present invention" from the prior art, as the rotationally leading placement reduces cutter and depth of cut limiting structure wear and vertical misplacement in comparison to the rotationally trailing placement of depth of cut limiting structures known in the prior art. Id. at col. 8:51-col. 9:40.

In total, the specification shows that application of the doctrine of claim differentiation would improperly broaden the claim terms. *See O.I. Corp. v. Tekmar Co.*, 115 F.3d 1576, 1582 (Fed.Cir.1997) ("Although the doctrine of claim differentiation may at times be controlling, construction of claims is not based solely upon the language of other claims; the doctrine cannot alter a definition that is otherwise clear from the claim language, description, and prosecution history."); *see also SciMed Life Sys., Inc. v. Advanced Cardiovascular Sys., Inc.*, 242 F.3d 1337, 1341 (Fed.Cir.2001) ("Where the specification makes clear that the invention does not include a particular feature, that feature is deemed to be outside the reach of the claims of the patent, even though the language of the claims ... might be considered broad enough to

encompass the feature in question."). Thus, the "exterior structure," "exterior surface," "exterior feature," "bearing segments," "bearing area," and "at least one feature" must rotationally precede the respective associated cutters.FN20

FN20. Ref. No. 23 of Appendix B contains the disputed terms and their constructions.

Designed to the Particular Formation to be Drilled

ReedHycalog claims the "exterior structure," "bearing segments," and "features" claimed in the '0 and '631 Patents must be "tailored" to or "designed" for the particular subterranean formation to be drilled. Baker Hughes argues a "tailored" or "designed" limitation should not be read into the claims.

ReedHycalog bases its construction on the '0 and '631 Patents specifications, which note the failure of prior art depth of cut limiting structures to implement an "engineered approach" to achieve a target rate of penetration and a predictable, stable bit performance. '0 Patent col. 2:36-41; '631 Patent col. 2:53-57. Further, ReedHycalog supports its construction with language from the '0 and '631 Patents specifications which state the invention provides a bit design that may be tailored to specific compressive strengths. '0 Patent col. 2:46-51; '631 Patent col. 3:2-7.

ReedHycalog also bases its construction on statements Baker Hughes made to the U.K. Patent Office during prosecution of the U.K. counterpart to the '930 Patent. In response to a rejection by the U.K. Patent Office Examiner, Baker Hughes stated it was "the first to recognize the need to tailor the area of the bearing surfaces to the compressive strength of a particular subterranean formation to be drilled so as to optimise the rate of penetration by obtaining a controlled depth of cut" ReedHycalog's Response to Baker Hughes's Opening Markman Brief, Exh. 12 at 1-2. Further, Baker Hughes stated "the present invention is not limited to any particular type of formation but rather lies in matching the depth of cut controlling features of the drill bit to the formation drilled, by reference to the compressive strength of the formation." Id. at 2.

Nothing in the '0 or '631 Patents indicates the claims should contain a "tailored" or "designed" limitation. The claims themselves do not contain a "tailored" or "designed" limitation. The specification states the prior art failed to implement an "engineered approach" and mentions that the bit design may be tailored, but these statements are not sufficient to import a "tailored" or "designed" limitation into the claims.

Baker Hughes's statements to the U.K. Patent Office also do not justify importation of a "tailored" or "designed" limitation, as "differences in international requirements for patent prosecution could make reliance on representations before foreign patent offices inappropriate" in the context of claim construction. *Burns, Morris & Stewart Ltd. v. Masonite Int'l Corp.*, 401 F.Supp.2d 692, 698 (E.D.Tex.2005) (Clark, J.) (citing *TI Group Auto. Sys. (N. Am.), Inc. v. VDO N. Am., L.L.C.*, 375 F.3d 1126, 1136 (Fed.Cir.2004)). To clarify its statements to the U.K. Patent Office Examiner, Baker Hughes added "through a formation of determined or predicted compressive stress" to the claims of the U.K. counterpart patent. ReedHycalog's Response to Baker Hughes's Opening Markman Brief, Exh. 12 at 2. This, or similar, claim language is not present in the '0 or '631 Patent claims. Thus, to import a "tailored" or "designed" limitation based on U.K. Patent Office proceedings, without a complete understanding of the actions by Baker Hughes and the U.K. Patent Office and their applicability to the patents in this case, would be inappropriate. *See Burns, Morris & Stewart Ltd.*, 401 F.Supp.2d at 698 (citing *TI Group Auto. Sys. (N. Am.), Inc.*, 375 F.3d at 1136). Therefore,

the terms "exterior structure," "bearing segments," and "features" do not contain a "tailored" or "designed" limitation.FN21

FN21. Ref. No. 23 of Appendix B contains the disputed terms and their constructions.

Compressive Strength of the Formation

Claims in the '0 and '631 Patents contain the terms "compressive strength" of the formation, "failure of the formation," and related terms. Baker Hughes contends "compressive strength" means "the confined, constrained, in situ, unconstrained or unconfined compressive strength." It does not construe "failure of the formation." ReedHycalog contends "compressive strength" means "the confined (in situ) compressive strength" and contends "failure of the formation" means "crush or indent any portion of (i.e. exceed the in situ compressive strength of) the particular subterranean formation."

The claim language in the '0 and '631 Patents only requires "compressive strength" and does not specify whether that strength is the confined or unconfined compressive strength. *E.g.* '0 Patent col. 15:47-48 ("so as to maintain a unit load on the formation below a compressive strength thereof"). The '0 and '631 Patents are directed towards subterranean drilling. *See* '0 Patent Abstract; '631 Patent Abstract. A person of ordinary skill in the art would determine the relevant compressive strength of the formation is the formation's compressive strength when in contact with the drill bit-in the borehole. This is the in situ compressive strength.

ReedHycalog's "failure of the formation" construction is accurate and will help the jury. The '0 and '631 Patents equate "substantially indent the formation" and "fail the formation." '0 Patent col. 3:5-8; '631 Patent col. 3:39-40. A drill bit will also fail the formation when it crushes the formation. Thus, the compressive strength and failure of the formation terms are construed accordingly.FN22

FN22. Ref., No. 24 of Appendix B contains the disputed terms and their constructions.

Excess Weight on Bit

Claims in the '0 and '631 Patents include the following "excess weight on bit" limitations: "a weight on bit greater than the selected weight"; "a weight on bit in excess of that required"; "a weight on bit greater than the selected weight"; and a "greater weight on bit" than that required to cause the cutter to cut the formation at the selected depth of cut. Baker Hughes contends these similar terms require the "amount of weight applied along the centerline of the drill bit body" to be "greater" or "larger than the weight required" for the cutter to cut into the formation at a selected depth of cut, but not more weight than one may normally expect or encounter. ReedHycalog contends the excess weight on bit terms do not have an upper bound and mean "regardless of the weight that is applied to the bit." Baker Hughes argues the claim language does not contain words of infinite scope and a claim construction that allows an infinite amount of weight on the drill bit is nonsensical.

ReedHycalog cites two portions of the '631 Patent specification, the Abstract and Summary of the Invention sections, to support its constructions. These state the claimed invention acts to control the torque on bit, depth of cut, and volume of formation cut per bit rotation, "regardless" of the amount of weight on bit. '631 Patent Abstract, col. 4:8-13.

A person of ordinary skill in the art would not conclude the '0 and '631 Patents disclose a drill bit capable of operation when an infinite amount of weight is applied to the bit. Moreover, a person of ordinary skill in the art would not interpret "regardless of the amount of weight on bit" and similar phrases to mean the drill bit can control the depth of cut, volume of formation material cut per but rotation, and torque on bit for all excess weights. Further, the claims and specifications do not support a construction that allows for an infinite amount of weight on bit. Thus, the Court construes the excess weight on bit terms to require the weight to be neither abnormal nor unusual.FN23

FN23. Ref. No. 25 of Appendix B contains the disputed terms and their constructions.

Depth of Cut for the Plurality of Cutters

Claims in the '0 and '631 Patents require the step of selecting or limiting a depth of cut, a maximum depth of cut, or a cutter exposure for the plurality of cutters. Baker Hughes contends these terms mean "selecting or choosing a depth for the plurality of cutters to cut into the formation during drill bit rotation." ReedHycalog contends these terms mean "selecting the same depth of cut for all of the plurality of cutters." The dispute centers on whether the claims require selecting the same depth of cut for all cutters.

In patent parlance, the terms "a" and "the" carry the presumptive meaning of "one or more" when used in open-ended claims that contain the transitional phrase "comprising." *Good Sportsman Mktg. LLC v. Testa Assocs., LLC*, 440 F.Supp.2d 570, 578-79 (E.D.Tex.2006) (Davis, J.) (citing *Free Motion Fitness, Inc. v. Cybex Int'l, Inc.*, 423 F.3d 1343, 1350-51 (Fed.Cir.2005)). If the claim specifically lists the number of elements or if the patent reveals the patentee's clear intent to limit the article, the presumption no longer applies and the claim term has a singular meaning. *Id.* (citing *Free Motion Fitness, Inc.*, 423 F.3d at 1350).

The '0 and '631 Patent claims, which contain the transitional phrase "comprising," vary between use of "a" and "the" in the claim terms. '0 Patent col. 19:46-51 ("selecting a depth of cut for the plurality of cutters"); '0 Patent col. 20:24-28 ("selecting a depth of cut for the plurality of superabrasive cutters"); '631 Patent col. 32:54-60 ("limiting the maximum depth-of-cut of a plurality of superabrasive cutters"); *id.* at col. 33:18-30 ("limiting a maximum depth-of-cut of a plurality of superabrasive cutters"); *id.* at col. 33:31-37 ("limiting the extent of exposure of each of the plurality of superabrasive cutters"). Thus, the plural meaning presumption applies, and the presumptive construction allows for one or more depths of cut, maximum depths of cut, and cutter exposure for the plurality of cutters.

The '631 and '0 Patents do not rebut the presumption of plurality. The '631 Patent specification specifically states "cutter exposure H_C generally differs for each of the cutters." '631 Patent col. 2:4-7. Further, Figs. 15A, 15B, and 15C of the '631 Patent show different cutter exposures for cutters along the blade of the drill bit, labeled H_C in Fig. 15A, which is annotated in Appendix C.

The '631 Patent also supports the presumption of plurality with regard to the maximum depth of cut terms. The specification shows that each cutter may have a different maximum depth of cut, as a cutter's exposed height limits how deep the cutter can cut into the formation. *Id.* at Figs. 18B, 18C, col. 25:13-19, col. 25:27-37, col. 26:4-12.

Finally, nothing in the '0 or '631 Patents requires all the cutters to cut the formation to the same depth. It

appears from Figs. 18B and 18C in the ' 631 Patent that a cutter's depth of cut is roughly equal to the difference between the cutter exposure and the gap. Id. at Fig. 18B, 18C. The gap, labeled G1 in Fig. 18B, partially depends on the weight applied to the bit and the design weight applied to the bit, which is the weight on bit that would virtually eliminate the gap for a given rate of penetration and compressive strength of the formation. Id. at col. 25:12-23. Nothing in the '0 or ' 631 Patents suggests the difference between the cutter exposure and the gap is equal for all cutters in the plurality at all times.

Thus, the selecting or limiting a depth of cut, a maximum depth of cut, or a cutter exposure for the plurality of cutters terms do not require a single depth of cut, maximum depth of cut, or cutter exposure for all cutters in the plurality.FN24 Accordingly, these terms do not require construction.

FN24. Ref. Nos. 28 and 30 of Appendix B contains the disputed terms and their constructions.

Penetrate

Claims in the '0 and '631 Patents require the cutters to "penetrate" the formation or "penetration" of the formation. Baker Hughes contends "penetrate" means "cut into." ReedHycalog contends "penetrate" means "shear." Baker Hughes uses the term "penetrate," and ReedHycalog uses the term "shear" to construe related terms in dispute.

The Court agrees with Baker Hughes. All of the patents-in-suit use the term "depth of cut" and refer to "cutters" that penetrate the formation. Thus, "penetrate" means "cut into," and "penetration" means "cutting into." FN25

FN25. Ref. No. 27 of Appendix B contains the disputed terms and their constructions.

Engage a Formation

Claims in the '0 and '631 Patents require a cutter to "engage" a formation or be in the process of "engaging" a formation. Baker Hughes contends a cutter engages a formation when the cutter to cuts into it. ReedHycalog claims the cutter must maintain continuous and uninterrupted contact with the subterranean formation to engage the formation but did not brief the term in its Response to Baker Hughes's Opening Markman Brief.

The '0 and '631 Patents use the term "engage," with respect to the cutters, synonymously with "cut into" and do not require the cutters to maintain continuous and uninterrupted contact with the formation. *See, e.g.*, ' 930 Patent col. 2:55-61 ("PDC cutters of the bit are engaged with the formation to their design DOC"); '631 Patent col. 3:16-21 (same); '0 Patent col. 14:40-48 ("DOCC features will prevent ... cutters from engaging the formation at too great a depth"); '631 Patent col. 4:58-62 ("PDC cutters are prevented from engaging the formation to a greater depth of cut"); id. at col. 18:46-53 ("DOCC features will prevent ... cutters from engaging the formation to too great a depth"); id. at col. 24:64-col. 25:2 (stating cutters create a formation cutting, or chip, as "cutters engage the formation at a given DOC"). Thus, "engage" means "cut into," and "engaging" means "cutting into." FN26

FN26. Ref. No. 29 of Appendix B contains the disputed terms and their construction.

Hard Facing

Claims in the '631 Patent contain the terms "an exterior hard facing," "a hard facing," and "a hard facing material." ReedHycalog contends "hard facing" is limited to nickle carbide or tungsten carbide. Baker contends "hard facing" means "a material that resists being worn away by abrasion during drilling" and lists 10 materials as examples of hard facing.

The '631 Patent does not define "hard facing" and offers little guidance. Claim 7 of the '631 Patent claims a drill bit "wherein the bit body comprises steel and the at least one bearing surface of at least one of the plurality of blade structures includes an exterior hard facing." Id. at col. 30:11-14. Claim 8, a dependant claim, claims the same drill bit "wherein the exterior hard facing comprises tungsten carbide particles." Id. at col. 30:15-16. Therefore, as delineated above, it is presumed under the doctrine of claim differentiation that "hard facing" is not limited to tungsten carbide particles.

Claim 11 claims a drill bit "wherein the wear-resistant exterior comprises at least one of the group consisting of carbide, tungsten carbide, synthetic diamond, natural diamond, polycrystalline diamond, thermally stable polycrystalline diamond, cubic boron nitride, and hard facing material." Id. at col. 30:25-30. While this claim appears to list separate materials, claim 8 indicates "hard facing" can contain tungsten carbide, one of the materials listed in claim 11. Id. at col. 30:15-16. Therefore, the claim 11 list does not exclude the other listed materials from the construction of "hard facing."

The specification also does not define the term. It lists "hard facing" as a type wear-resistant feature apart from embedded-diamonds, thermally stable PDCs, PDCs, weldings, and weldments. Id. at col. 20:40-44. However, the specification does not limit "hard facing" to any type of material or state that "hard facing" cannot comprise the other listed wear-resistant materials.

Logic dictates that "hard facing" is a material harder than the material it is applied to. As such, "hard facing" includes those materials listed in the specification, in addition to other materials, when those materials are harder than the surface they are applied to. Thus, "hard facing" and "hard facing material" mean "wear-resistant material that is harder than the material onto which it is applied." FN27

FN27. Ref., No. 32 of Appendix B contains the disputed terms and their constructions.

Built Up With a Hard Facing

Claims in the '631 Patent require a bearing surface "built up with a hard facing." Baker Hughes contends "built up" means "raised or built up, or increasing surface height." ReedHycalog contends "built up" means "appreciably raised." A lay jury will understand the term "built up" and therefore the term requires no construction.FN28

FN28. Ref. No. 33 of Appendix B contains the disputed terms and their constructions.

CONCLUSION

For the foregoing reasons, the Court interprets the claim language in this case in the manner set forth above.

For ease of reference, the Court's claim interpretations are set forth in a table as Appendix B. Referenced figures from the '249, '715, '0, and '631 Patents appear in Appendix C with the Court's annotations. The claims with the disputed terms in bold are set forth in Appendix A.

So **ORDERED**.

APPENDIX A

U.S. Pat. No. 6,443,249

1. A rotary drag bit for drilling a subterranean formation, comprising:

a bit body comprising at least a **first region** and a **second region** over a face to be oriented toward the subterranean formation during drilling; and

a plurality of cutters secured to the bit body in the **first and second regions**, the cutters of the plurality each comprising a cutting face having a preselected **effective cutting face backrake angle**, and being positioned substantially transverse to a direction of cutter movement during drilling and including a cutting edge located to engage the subterranean formation, wherein the respective cutting faces of a majority of cutters located in the **first region** exhibit **substantially larger effective cutting face backrake angles** than the **effective cutting face backrake angles** of the respective cutting faces of a majority of cutters located in the **second region**.

2. The rotary drag bit of claim 1, wherein the **first region** lies within a **cone** on the face of the bit body, and the **second region** extends at least over a **nose** and **flank** on the face of the bit body.

3. The rotary drag bit of claim 2, wherein the **second region** extends to a **gage** of the bit body.

7. The rotary drag bit of claim 1, wherein the bit body further includes a plurality of generally radially oriented blades extending over the bit body face and to a **gage**, and wherein the **first region** cutters and the **second region** cutters are located on the generally radially oriented blades.

8. The rotary drag bit of claim 1, wherein the **effective cutting face backrake angles** of the cutters are determined at least in part by cutter backrake angles of the cutters.

9. The rotary drag bit of claim 8, wherein each of the cutters in the **first region** is oriented at a backrake angle greater than each of the backrake angles of the cutters in the **second region**.

10. The rotary drag bit of claim 1, wherein the **first region** lies within a **cone** on the face of the bit body, and the **second region** extends at least over a **nose** on the face of the bit body.

11. The rotary drag bit of claim 10, wherein at least one cutter proximate a **gage** portion of the bit body is backraked at an angle less than a cutter backrake angle of at least one cutter in the **first region**.

U.S. Pat. No. 7,000,715

1. A rotary drag bit for drilling a subterranean formation, comprising:

a bit body having a longitudinal axis and extending radially outward therefrom to a **gage**, the bit body further comprising at least a **first region**, a **second region**, and a **third region**, **radially intermediate the first and second regions**, extending over a face of the bit body to be oriented toward the subterranean formation during drilling; and

a plurality of cutters located on the bit body in the **first, second, and third regions**, the cutters each comprising a superabrasive cutting face of a preselected geometry and including a preselected **effective cutting face backrake angle** with respect to a line generally perpendicular to the subterranean formation, as taken in the direction of intended bit rotation, and wherein the respective superabrasive cutting faces of a majority of cutters located in the **first region** exhibit **substantially more negative effective cutting face backrake angles** than the **effective cutting face backrake angles** of the respective superabrasive cutting faces of a majority of cutters located in the **second and third regions**.

2. The rotary drag bit of claim 1, wherein the **first region** lies within a **cone** of the face of the bit body, the **second region** extends over at least a **flank** on the face of the bit body, and the **third region** extends over at least a **nose** of the face of the bit body.

3. The rotary drag bit of claim 2, wherein the **second region** extends to the **gage** of the bit body

52. A method of drilling a subterranean formation comprising:

providing a rotary drag bit comprising: a bit body having a longitudinal axis and extending radially outwardly therefrom to a **gage**, the bit body configured to comprise at least a **first region** radially proximate the longitudinal axis, a **second region** radially proximate the **gage**, and a **third region radially intermediate the first and second regions**;

a plurality of cutters located on the bit body in the **first, second, and third regions**, the plurality of cutters each comprising a superabrasive cutting face having preselected geometry and exhibiting a preselected **effective cutting face backrake angle** with respect to a line generally perpendicular to the formation, as taken in a direction of intended bit rotation, wherein the respective cutting faces of a majority of the cutters located in the **first region** exhibit **effective cutting face backrake angles which are substantially less aggressive** than the **effective cutting face backrake angles** of the respective cutting faces of a majority of cutters located in the **second and third regions**;

orienting a face of the bit body toward a subterranean formation;

rotating the bit body at a selected rotational speed while applying a weight upon the rotary drag bit; and

engaging the subterranean formation with cutters located on at least one of the **first, second, and third regions** of the bit body so as to **penetrate** the subterranean formation at a greater rate of penetration and at a lower **torque-on-bit** as compared to a rate-of-penetration and a **torque-on-bit** generated by a **conventional rotary drag bit** drilling the same subterranean formation at approximately the same rotational speed.

53. The method of claim 52, wherein providing a rotary drag bit further comprises configuring the bit body to comprise a plurality of blade structures, each of the blade structures extending generally longitudinally along the bit body from generally the **first region** through the **third region** and at least generally to the

second region.

57. The method of claim 52, wherein providing a rotary drag bit further comprises orienting a majority of the cutters located generally in the **first region** to have a backrake angle within a first range of cutter backrake angles, orienting a majority of the cutters generally located in the **second region** to have a cutter backrake angle within a second range of cutter backrake angles, and orienting a majority of the cutters generally located in the **third region** to have a cutter backrake angle within a third range of cutter backrake angles.

62. The method of claim 52, wherein providing a rotary drag bit comprising a plurality of cutters located thereon comprises selectively varying each of the preselected **effective cutting face backrake angles** of the cutters located on the bit body in the **first, second, and third regions** by selectively varying at least one of a cutter backrake angle, providing a cutting face having a preselected geometry comprising configuring the cutting face to include a chamfer of a preselected width and chamfer angle, and varying the respective cutting face angles in relation to the radial distance from the longitudinal axis in which the cutter bearing the respective cutting face is located.

91. A method of designing a rotary drag bit for drilling a subterranean formation, comprising:

selecting a configuration for a bit body having a longitudinal axis and extending radially outward therefrom to a **gage**, the bit body further comprising a face of the bit body to be oriented toward the subterranean formation during drilling and exhibiting a **profile** along which a plurality of cutters are to be placed; and

selecting a plurality of cutters to be located on the bit body over the face and along the **profile**, the cutters of the plurality each comprising a superabrasive cutting face, the selecting further comprising selecting at least one cutting geometry characteristic for at least some of the cutters of the plurality from the group consisting of cutter backrake angle, **effective cutting face backrake angle**, chamfer angle, chamfer width and **chamfer backrake angle** to enable the bit to exhibit a lower **torque-on-bit** for a given rate-of-penetration as compared to a **torque-on-bit** generated by a **conventional rotary drag bit** drilling the same subterranean formation at approximately the same rotational speed.

92. The method of claim 91, further comprising selecting the at least one cutting geometry characteristic to enable the rotary drag bit to exhibit directional drilling behavior substantially equal to that of the **conventional rotary drag bit**.

94. A method of altering a torque response of a rotary drag bit for drilling a subterranean formation, comprising:

selecting a configuration for a bit body having a longitudinal axis and extending radially outward therefrom to a **gage**, the bit body further comprising a face of the bit body to be oriented toward the subterranean formation during drilling and exhibiting a **profile** along which a plurality of cutters are to be placed;

selecting a plurality of cutters to be located on the bit body over the face and along the **profile**, the cutters of the plurality each comprising a superabrasive cutting face, wherein each cutter of the plurality exhibits at least one cutting geometry characteristic selected from the group consisting of cutter backrake angle, effective cutting face backrake angle, chamfer angle, chamfer width and **chamfer backrake angle**; and

modifying at least one cutting geometry characteristic of at least one cutter of the plurality in relation to a torque response associated therewith.

96. The method of claim 94, wherein modifying at least one cutting geometry characteristic of at least one cutter of the plurality comprises enabling the rotary drag bit to exhibit a lower **torque-on-bit** for a given rate-of-penetration as compared to a **torque-on-bit** generated by the rotary drag bit drilling at approximately the same rotational speed without the modification of the at least one cutting geometry characteristic of the at least one cutter of the plurality.

U.S. Pat. No. 6,298,930

1. A drill bit for subterranean drilling, comprising:

a bit body including a leading end for contacting a formation during drilling and a trailing end having structure associated therewith for connecting the drill bit to a drill string;

at least one superabrasive cutter secured to the bit body over the leading end **at a radius from a centerline of the bit body**; and

exterior structure on the leading end **disposed substantially at the radius** and exhibiting sufficient surface area, when in contact with the formation, to control **penetration** of the at least one superabrasive cutter into the formation under weight on bit by distributing the weight on bit so as to maintain a unit load on **the formation below a compressive strength thereof**.

2. The drill bit of claim 1, wherein the at least one superabrasive cutter comprises a plurality of superabrasive cutters, each of the plurality of superabrasive cutters positioned **at a radius from the centerline**, and the exterior structure on the leading end comprises a plurality of **bearing segments** having bearing surfaces and protruding from the bit body, each **bearing segment** of the plurality **disposed substantially at the radius** of one of the plurality of superabrasive cutters, wherein a combination of bearing surfaces of **bearing segments** of the plurality exhibits the sufficient surface area.

15. The drill bit of claim 2, wherein at least some portions of the bearing surfaces of at least some of the **bearing segments** of the plurality are provided with wear-resistant structures.

17. A drill bit for subterranean drilling, comprising:

a bit body including a leading end for contacting a formation during drilling and a trailing end having structure associated therewith for connecting the drill bit to a drill string;

at least one superabrasive cutter secured to the bit body over the leading end **at a radius from a centerline of the bit body**; and

at least one feature on the leading end **disposed substantially at the radius** and sized and configured so as to limit a depth of cut of the at least one superabrasive cutter into the formation through distribution of an axial load applied to the drill bit during drilling over a surface area sufficient to avoid **failure of the formation**.

18. The drill bit of claim 17, wherein the at least one superabrasive cutter comprises a plurality of superabrasive cutters, each of the plurality of superabrasive cutters positioned **at a radius from the centerline**, and the at least one feature on the leading end comprises a plurality of **bearing segments** having bearing surfaces and protruding from the bit body, each **bearing segment** of the plurality **disposed substantially at the radius** of one of the plurality of superabrasive cutters, wherein a combination of bearing surfaces of bearing segments of the plurality is sized and configured to provide the sufficient surface area.

31. The drill bit of claim 18, wherein at least some portions of the bearing surfaces of at least some of the **bearing segments** of the plurality are provided with wear-resistant structures.

37. A method of designing a bit for subterranean drilling, comprising:

determining a compressive strength of at least one formation to be drilled;

selecting a plurality of superabrasive cutters required on the bit under design to drill a borehole;

determining a total weight on bit required to cause the plurality of superabrasive cutters to **penetrate** the at least one formation; and

determining a surface area for at least one **exterior feature** on a leading end of the bit over which the plurality of superabrasive cutters is mounted sufficient to support the bit thereon under a **weight on bit at least as great as the total weight on bit** without **failure of the at least one formation**.

42. A method of designing a bit for subterranean drilling, comprising:

determining a compressive strength of at least one formation to be drilled;

selecting a plurality of superabrasive cutters required on the bit under design to drill a borehole;

determining a total weight on bit required to cause the plurality of cutters to **penetrate** the at least one formation; and

determining a sufficient surface area for at least one **exterior feature** on a leading end of the bit over which the plurality of cutters is mounted to support the bit thereon under **at least the total weight on bit** to maintain a unit load on **the at least one formation less than a compressive strength thereof**.

44. The method of claim 42, further comprising **selecting a depth of cut for the plurality of cutters** and disposing the at least one **exterior feature** to preclude **penetration** of the at least one formation to a magnitude greater than the selected depth of cut.

47. A method of designing a bit for subterranean drilling, comprising:

determining a compressive strength of at least one formation to be drilled;

selecting a plurality of superabrasive cutters required on the bit under design to drill a borehole;

determining a total weight on bit required to cause the plurality of cutters to **penetrate** the at least one formation; and

determining an area of at least one **exterior surface** feature on a leading end of the bit sufficient to preclude **plastic failure of the at least one formation** under **at least the total weight on bit**.

49. The method of claim 47, further comprising **selecting a depth of cut for the plurality of superabrasive cutters** and disposing the at least one **exterior feature** to preclude **penetration** of the at least one formation to a magnitude greater than the selected depth of cut.

52. A method of drilling a subterranean formation, comprising:

engaging the formation with at least one cutter of a drill bit to a selected depth of cut; and

maintaining the selected depth of cut during application of a **weight on bit in excess of that required** for the at least one cutter to **penetrate** the formation to the selected depth of cut by providing a **bearing area** on the drill bit to distribute the **excess weight on bit** sufficient to achieve a unit load by the bearing area on the formation **less than a compressive strength of the formation**.

53. A method of drilling a subterranean formation, comprising:

engaging the subterranean formation with at least one cutter of a drill bit to a selected depth of cut; and

maintaining the selected depth of cut during application of a **weight on bit in excess of that required** for the at least one cutter to **penetrate** the subterranean formation to the selected depth of cut by providing a **bearing area** on the bit sufficient to support the drill bit on **the subterranean formation without failure thereof**.

54. The method of claim 53, further comprising maintaining the selected depth of cut under the **excess weight on bit** by supporting the bit on **the subterranean formation without precipitating substantial plastic deformation thereof**.

55. A method of drilling a subterranean formation, comprising:

applying a selected weight to cause at least one cutter of a drill bit to **engage** a formation to a selected depth of cut; and

precluding subsequent **penetration** of the at least one cutter into the formation in excess of the selected depth of cut during application of a **weight on bit greater than the selected weight** by providing a **bearing area** on the drill bit to distribute the greater weight on bit sufficient to achieve a unit load by the bearing area on the formation **less than a compressive strength of the formation**.

56. The method of claim 55, further comprising maintaining the selected depth of cut under the **greater weight on bit** by supporting the bit on **the formation without precipitating substantial plastic deformation thereof**.

57. A method of drilling a subterranean formation, comprising:

applying a selected weight to cause at least one cutter of a drill bit to **engage** a formation to a selected depth; and

precluding subsequent **penetration** of the at least one cutter into the formation in excess of the selected depth of cut during application of a **weight on bit greater than the selected weight** by providing a **bearing area** on the drill bit sufficient to support the drill bit on **the formation without failure thereof**.

U.S. Pat. No. 6,460,631

1. A drill bit for subterranean drilling, comprising:

a bit body including a longitudinal centerline, a leading end having a face for contacting a formation having a **maximum compressive strength during drilling**, and a trailing end having a structure associated therewith for connecting the bit body to a drill string, the face of the leading end configured to include a total bearing surface of a size sufficient to substantially support the bit body upon the bit body being forced against the formation at a **maximum weight-on-bit** resulting in a unit load on the formation not **exceeding the maximum compressive strength of the formation**; and

at least one superabrasive cutter for **engaging** the formation during drilling secured to a selected portion of the face of the leading end of the bit body, the at least one superabrasive cutter exhibiting a limited amount of cutter exposure perpendicular to the selected portion of the face of the leading end to which the at least one superabrasive cutter is secured to, in combination with the total bearing surface of the bit body, limit a maximum depth-of-cut of the at least one superabrasive cutter into the formation **having the maximum compressive strength during drilling**.

2. The drill bit of claim 1, wherein the at least one superabrasive cutter comprises a plurality of superabrasive cutters and the face of the leading end comprises a plurality of blade structures protruding from the bit body, at least some of the plurality of blade structures carrying at least one of the plurality of superabrasive cutters and the blade structures exhibiting in total a combined bearing surface area of sufficient size to maintain the unit load on **the formation not exceeding the maximum compressive strength thereof**.

3. The drill bit of claim 2, wherein the at least some of the plurality of blade structures each extend from a respective point generally proximate the longitudinal centerline of the bit body generally radially outward toward a gage of the bit body and longitudinally toward the trailing end of the bit body.

4. The drill bit of claim 3, wherein the at least some of the plurality of blade structures each carry several of the plurality of superabrasive cutters and exhibit at least one bearing surface, and wherein each of the plurality of blade structures generally encompasses each of the several of the plurality of superabrasive cutters carried thereon with a limited portion of each of the several superabrasive cutters exposed by a preselected extent perpendicular from the respective at least one bearing surface proximate each of the several superabrasive cutters so as to control a respective depth-of-cut for each of the several superabrasive cutters.

7. The drill bit of claim 4, wherein the bit body comprises steel and the at least one bearing surface of at least one of the plurality of blade structures includes an **exterior hard facing**.

10. The drill bit of claim 4, wherein the at least one bearing surface is **built up with a hard facing** on at least a portion thereof substantially surrounding at least one of the plurality of superabrasive cutters so as to effectively limit an amount of exposure of the at least one of the superabrasive cutters.

12. The drill bit of claim 4, wherein the face of the leading end of the bit body comprises a **cone, nose, flank, shoulder, and gage region**.

13. The drill bit of claim 12, wherein at least one of the plurality of superabrasive cutters is positioned in the **cone region** and exhibits a lesser amount of cutter exposure than at least one other of the plurality of superabrasive cutters positioned in the **nose region**.

14. The drill bit of claim 13, wherein the at least one other superabrasive cutter positioned in the **nose region** exhibits a greater amount of cutter exposure than the at least one superabrasive cutter positioned in the **cone region**.

25. The drill bit of claim 3, wherein at least one superabrasive cutter of the plurality includes an **effective backrake angle** not exceeding approximately 20 (deg.) with respect to an intended direction of drill bit rotation perpendicular to the formation to be **engaged** by the at least one superabrasive cutter of the plurality.

26. The drill bit of claim 25, further comprising a superabrasive cutter of the plurality positioned and secured to the bit body in a **gage region** of the drill bit and having an **effective backrake angle** substantially exceeding approximately 20 (deg.).

33. A method of drilling a subterranean formation without generating an **excessive amount of torque-on-bit**, comprising:

engaging the formation with at least one cutter of a drill bit within a selected depth-of-cut range; and

limiting a maximum depth-of-cut of the at least one cutter during application of a **weight-on-bit in excess of that required** for the at least one cutter to **penetrate** the formation within the selected depth-of-cut range.

34. The method of claim 33, further comprising limiting the maximum depth-of-cut of the at least one cutter during application of **the excess weight-on-bit** by providing at least one formation-facing bearing surface on the drill bit generally surrounding at least a portion of the at least one cutter and limiting an extent of exposure of the at least one cutter generally perpendicular to the at least one formation-facing bearing surface.

35. The method of claim 34, further comprising maintaining the maximum depth-of-cut of the at least one cutter under the **excess weight-on-bit** by providing a total formation-facing bearing area on the drill bit sufficient to axially support the drill bit on the formation without **substantial failure of the formation** axially underlying the drill bit.

36. The method of claim 35, further comprising maintaining the selected depth-of-cut range under the **excess weight-on-bit** by supporting the drill bit on **the formation without precipitating substantial**

plastic deformation thereof.

37. The method of claim 34, further comprising: applying a selected weight to cause the at least one cutter of the drill bit to **engage** the formation to a selected depth of cut; and

precluding subsequent **penetration** of the at least one cutter into the formation in excess of the selected depth of cut during application of a **weight-on-bit greater than the selected weight.**

38. The method of claim 37, further comprising maintaining the selected depth of cut under the **greater weight-on-bit** by providing a bearing area on the drill bit to distribute the **greater weight-on-bit** sufficient to achieve a unit load by the bearing area on the formation **less than a compressive strength of the formation.**

39. The method of claim 33, wherein **limiting the maximum depth-of-cut of the at least one cutter** comprises **limiting the maximum depth-of-cut of a plurality of superabrasive cutters**, each being limited to generally an equal amount of cutter exposure perpendicular to a selected portion of an outward face of a leading end to which each of the plurality of superabrasive cutters is secured.

42. The method of claim 34, wherein limiting the maximum depth-of-cut of the at least one cutter during application of the **excess weight-on-bit** by providing the at least one formation-facing bearing surface generally surrounding the at least a portion of the at least one cutter and limiting the extent of exposure of the at least one cutter generally perpendicular to the at least one formation-facing bearing surface comprises **limiting a maximum depth-of-cut of a plurality of superabrasive cutters** and wherein several of the plurality of superabrasive cutters are respectively secured to a plurality of blade structures extending radially outwardly from a longitudinal axis of the drill bit generally toward a gage region of the drill bit.

43. The method of claim 42, wherein **limiting the maximum depth-of-cut of the plurality of superabrasive cutters** comprises respectively limiting the extent of exposure of each of the plurality of superabrasive cutters perpendicular to the respective at least one formation-facing bearing surface proximate each of the plurality of superabrasive cutters to a selected cutter exposure height.

50. The method of claim 43, wherein respectively limiting the extent of exposure of each of the plurality of superabrasive cutters perpendicular to the respective at least one formation-facing bearing surface proximate each of the plurality of superabrasive cutters to the selected cutter exposure height comprises applying a **hard facing material to build up** a selected portion of the respective at least one formation-facing bearing surface proximate at least one of the superabrasive cutters so as to further limit the extent of exposure of the at least one of the superabrasive cutters.

51. The method of claim 50, wherein applying the hard facing material to build up the respective at least one formation-facing bearing surface comprises applying the hard facing material to a steel-bodied bit.

52. The method of claim 51, wherein applying the **hard facing material** to the steel-bodied bit comprises applying the **hard facing material** within at least a **cone region** of the steel-bodied bit.

64. A rotary drag bit for drilling subterranean formations comprising:

a bit body having a longitudinal axis and extending radially outward therefrom to a **gage**, the bit body

further comprising at least a **first region** and a **second region** over a face to be oriented toward at least one subterranean formation during drilling; and

a plurality of cutters secured on the bit body in the **first and second regions**, at least one of the plurality of cutters having a superabrasive cutting face having a preselected geometry and being positioned substantially transverse to a direction of cutter movement during drilling, and wherein the at least one cutter exhibits a limited amount of cutter exposure perpendicular to a portion of the formation-facing surface to which the at least one cutter is secured to control a maximum depth-of-cut of the at least one cutter into the formation during drilling.

65. The rotary drag bit of claim 64, wherein the **first region** comprises an area closer to the longitudinal axis of the bit body than the **second region** and the at least one cutter is located in the **first region**.

66. The rotary drag bit of claim 65, wherein the **first region** is a **cone region** on the face of the bit body and the at least one cutter secured to the formation-facing surface is located on a blade structure.

68. The rotary drag bit of claim 64, wherein the **first region** comprises a **cone region** and the **second region** comprises at least one of the group consisting of a **nose region**, a **shoulder region**, and a **flank region**.

78. The rotary drag bit of claim 64, wherein the at least one cutter exhibiting the limited amount of cutter exposure perpendicular to the portion of the formation-facing surface to which the at least one cutter is secured is substantially surrounded by **hard facing material**.

APPENDIX B

Ref. Nos.	Term or Phrase to be Construed (Claims)	Court's Constructions
1	cutter backrake angle(s) ('249 Patent, claims 8, 11) ('715 Patent, claims 57, 62, 91, 94)	AGREED-the angle between the longitudinal axis of the cutter body and the formation to be engaged by the cutter
	backrake angle ('249 Patent, claim 9) ('715 Patent, claims 57)	
2	backraked ('249 Patent, claim 11)	AGREED-the cutter is placed on the bit such that an angle exists between the longitudinal axis of the cutter body and the formation to be engaged by the cutter
3	effective cutting face backrake angle(s) ('249 Patent, claims 1, 8) ('715 Patent, 1, 52, 62, 91, 94)	angle(s) between a line oriented perpendicular to the subterranean formation to be engaged by a cutter and the portion(s) of the cutting face of the cutter that engages the formation during drilling, measured in the direction of intended bit rotation

negative effective cutting face backrake angle ('715

Patent, claims 1)

	effective backrake angle ('631 Patent, claim 25, 26)	
4	exhibit substantially larger effective cutting face backrake angles ('249 Patent, claim 1) exhibit substantially more negative effective cutting face backrake angles ('715 Patent, claim 1)	<i>No construction required.</i>
	exhibit effective cutting face backrake angles which are substantially less aggressive ('715 Patent, claims 52)	
5	cone ('249 Patent, claims 2, 10) ('715 Patent, claim 2)	radially innermost region, defined by the blades of the bit, located radially between the nose and the center longitudinal axis of the bit, labeled 230 in Fig. 10 of the '249 and '715 Patents
	cone region ('631 Patent, claims 12, 13, 14, 52, 66, 68)	
6	nose ('249 Patent, claims 2, 10) ('715 Patent, claim 2) nose region ('631 Patent, claims 12, 13, 14, 68)	region, defined by the blades of the bit, located radially between the cone and flank regions, and includes the leading-most point on the blades, labeled 232 in Fig. 10 of the '249 and '715 Patents
7	flank ('249 Patent, claim 2) ('715 Patent, claim 2)	region defined by the blades of the bit, located radially between the nose and the gage regions, labeled 234 in Fig. 10 of the '249 and '715 Patents
	flank region ('631 Patent, claims 12, 68)	
8	gage ('249 Patent, claims 3, 7, 11) ('715 Patent, claims 1, 2, 3, 52, 91, 94) ('631 Patent, claims 3, 64)	outermost radius of the bit, labeled 207 in Fig. 7 of the '249 and '715 Patents
	gage region ('631 Patent, claims 12, 26, 42)	region at the outermost radius of the bit, labeled 322 in Fig. 14A of the '631 Patent
9	shoulder region ('631 Patent, claims 12, 68)	region defined by the blades of the bit, located radially between the nose and gage regions if the shoulder region is incorporated with the flank region, and located radially between the flank and gage regions if the flank region exists separately, labeled 316 in Fig.16 of the '631 Patent.
10	first region ('249 Patent, claims 1, 2, 7, 9, 10, 11) ('715 Patent, claims 1, 2, 52, 53, 57, 62) ('631 Patent, claim 64)	area or region defined by the blades of the bit, located generally on the center of the bit face or on the leading end of the bit radially closest to the centerline or longitudinal axis

		of the drill bit body, labeled 226 in Fig. 10 of the '249 Patent and Figs. 10, 12, and 13 of the '715 Patent
11	second region ('249 Patent, claims 1, 2, 3, 7, 9, 10) ('715 Patent, claims 1, 2, 3, 52, 53, 57, 62) ('631 Patent, claim 64)	area or region defined by the blades of the bit, located generally radially distant or remote from the centerline or longitudinal axis of the drill bit body between the first region and the outer region at the maximum or outermost diameter of the face or leading end of the bit, labeled 228 in Fig. 10 of the '249 Patent and Figs. 10, 12, and 13 of the '715 Patent
12	third region ('715 Patent, claims 1, 2, 3, 52, 53, 57, 62)	area or region, if any, defined by the blades of the bit, located generally radially in between the first and second regions, labeled 226' in Figs. 12 and 13 of the '715 Patent
13	radially intermediate the first and second regions ('715 Patent, claims 1, 52)	<i>No construction required.</i>
14	chamfer backrake angle ('715 Patent, Claims 91, 94)	the angle between a line oriented perpendicular to the subterranean formation to be engaged by a cutter and the portion(s) of the chamfer that engages the formation during drilling, measured in the direction of intended bit rotation, labeled $(\beta)_1$ in Fig. 11 of the '715 Patent
15	profile ('715 Patent, claims 91, 94)	radial cross-section or outline of the bit, defined by the blades of the bit, labeled 224 in Fig. 10 of the '715 Patent
16	generally perpendicular to a longitudinal axis of the at least some of the plurality of cutters ('715 Patent, claim 30)	AGREED- <i>No construction required.</i>
17	conventional rotary drag bit ('715 Patent, claims 52, 91, 92)	<i>No construction required</i>
18	torque-on-bit ('715 Patent, claim 91, 96)	<i>No construction required</i>
19	modifying at least one cutting geometry characteristic of at least one cutter of the plurality in relation to a torque response associated therewith ('715 Patent, claim 94)	in relation to a torque response, modifying one of the following cutter characteristics of at least one cutter: (1) backrake angle; (2) effective cutting face backrake angle; (3) chamfer angle; (4) chamfer width; and (5) chamfer backrake angle
20	altering at least one cutting geometry characteristic of some of the cutters of the plurality ('715 Patent, claim 95)	AGREED-modifying one of the following cutter characteristics of more than one cutter of the plurality of cutters: (1) cutter backrake angle; (2) effective cutting face backrake angle; (3) chamfer angle; (4) chamfer width; and (5) chamfer backrake angle

21	at a radius from a centerline of the bit body ("0 Patent, claims 1, 17)	at a distance measured perpendicular (at a ninety degree angle) from the centerline of the drill bit body ("the radius")
----	---	--

	at a radius from the centerline ("0 Patent, claim 2, 18)	at a distance measured perpendicular (at a ninety degree angle) from the centerline ("the radius")
22	disposed substantially at the radius ("0 Patent, claim 1, 2, 17, 18)	located close to the radius

23	exterior structure ("0 Patent, claim 1)	rotationally preceding exterior structure
	exterior surface ("0 Patent, claim 47)	rotationally preceding exterior surface
	exterior feature ("0 Patent, claim 37, 42, 44, 49)	rotationally preceding exterior feature
	bearing area ("0 Patent, claim 52, 53, 55, 57)	rotationally preceding bearing area
	bearing segments ("0 Patent, claims 2, 15, 18, 31)	rotationally preceding bearing segments

	at least one feature ("0 Patent, claim 17)	at least one rotationally preceding feature
--	--	---

24	failure of the formation ("0 Patent, claim 17)	crushing or indenting any portion of (i.e., exceeding the in situ compressive strength of) the formation
----	--	--

the formation below a compressive strength thereof ("0 Patent, claim 1)	the formation so as to prevent the bit from crushing or indenting any portion of (i.e., exceeding the in situ compressive strength of) the formation
---	--

determining a compressive strength of at least one formation to be drilled ("0 Patent, claims 37, 42, 47)	determining the confined (in situ) compressive strength of at least one formation to be drilled
---	---

failure of the at least one formation ("0 Patent, claim 37)	crushing or indenting any portion of (i.e., exceeding the in situ compressive strength of) the formation
---	--

the at least one formation less than a compressive strength thereof ("0 Patent, claim 42)	the at least one formation so as to prevent the bit from crushing or indenting any portion of (i.e., exceeding the in situ compressive strength of) the at least one formation
---	--

plastic failure of the at least one formation ("0 Patent, claim 47)

crushing or indenting any portion of (i.e., exceeding the in situ compressive strength of) the at least one formation

less than a compressive strength of the formation ("0 Patent, claim 52, 55)

to prevent the bit from crushing or indenting any portion of (i.e., exceeding the in situ compressive strength of) the formation

the subterranean formation without failure thereof ("0 Patent, claim 53)

the subterranean formation so as to prevent the bit from crushing or indenting any portion of (i.e., exceeding the in situ compressive strength of) the subterranean formation

the subterranean formation without precipitating substantial plastic deformation thereof ("0 Patent, claim 54)

the subterranean formation so as to prevent the bit from substantially indenting (i.e., exceeding the in situ compressive strength of) any portion thereof

the formation without precipitating substantial plastic deformation thereof ("0 Patent, claim 56)

the formation so as to prevent the bit from substantially indenting (i.e., exceeding the in situ compressive strength of) any portion thereof

the formation without failure thereof ("0 Patent, claim 57)

the formation so as to prevent the bit from crushing or indenting any portion of (i.e., exceeding the in situ compressive strength of) the formation

exceeding the maximum compressive strength of the formation ('631 Patent, claim 1)

crushing or indenting any portion of (i.e., exceeding the in situ compressive strength of) the formation

the formation not exceeding the maximum compressive strength thereof ('631 Patent, claim 2).

the formation so as to prevent the bit from crushing or indenting any portion of (i.e., exceeding the in situ compressive strength of) the formation

substantial failure of the formation ('631 Patent, claim 35)

substantially crushing or indenting any portion of (i.e., exceeding the in situ compressive strength of) the formation

the formation without precipitating substantial plastic deformation thereof ('631 Patent, claim 36)

the formation so as to prevent the bit from substantially crushing or indenting any portion of (i.e., exceeding the in situ

compressive strength of) the formation

less than a compressive strength of the formation ('631 Patent, claim 38)

prevent the bit from substantially crushing or indenting any portion of (i.e., exceeding the in situ compressive strength of) the formation

	having a maximum compressive strength during drilling ('631 Patent, claim 1)	having a maximum confined (in situ) compressive strength
--	--	--

25 weight on bit at least as great as the total weight on bit ('0 Patent, claim 37)

weight on bit at least as great as the total weight on bit, but not an abnormal or unusual weight

at least the total weight on bit ('0 Patent, claims 42, 47)

at least the total weight on bit, but not an abnormal or unusual weight

weight on bit in excess of that required ('0 Patent, claims 52, 53)

weight on bit, but not an abnormal or unusual weight, in excess of that required

excess weight on bit ('0 Patent, claim 54)

weight on bit, but not an abnormal or unusual weight, in excess

greater weight on bit ('0 Patent, claim 56)

greater weight, but not an abnormal or unusual weight, on bit

weight on bit greater than the selected weight ('0 Patent, claim 55, 57)

weight on bit greater than the selected weight, but not an abnormal or unusual weight

weight-on-bit in excess of that required ('631 Patent, claim 33)

weight on bit, but not an abnormal or unusual weight, in excess of that required

weight-on-bit greater than the selected weight ('631 Patent, claim 37)

weight-on-bit greater than the selected weight, but not an abnormal or unusual weight,

excess weight-on-bit ('631 Patent, claims 34, 35, 36, 42)

weight on bit, but not an abnormal or unusual weight, in excess

	greater weight-on-bit ('631 Patent, claim 38)	greater weight, but not an abnormal or unusual weight, on bit
--	---	---

26 depth of cut / depth-of-cut ('0 Patent, claims 17, 44, 49, 52, 53, 54, 55, 56, 57) ('631 Patent, claims 1, 4, 33, 34,

AGREED-the depth to which a cutter cuts into a formation while drilling

	35, 36, 37, 38, 39, 42, 43, 64)	
27	penetrate ("0 Patent, claim 37, 42, 47)	cutting into
	penetration ("0 Patent, claims 44, 49) ('631 Patent, claims 33, 37)	cutting into
28	selecting a depth of cut for the plurality of cutters ("0 Patent, claims 44)	<i>No construction required</i>
	selecting a depth of cut for the plurality of superabrasive cutters ("0 Patent, claim 49)	
29	engage ("0 Patent, claim 55, 57) ('631 Patent, claim 37)	cut into
	engaging ("0 Patent, claim 52, 53) ('631 Patent, claim 1, 33)	cutting into
30	limiting a maximum depth-of-cut of the at least one cutter ('631 Patent, claim 33, 39)	<i>No construction required</i>
	limiting the maximum depth-of-cut of a plurality of superabrasive cutters ('631 Patent, claims 39, 43)	
	limiting a maximum depth-of-cut of a plurality of superabrasive cutters ('631 Patent, claim 42)	<i>No construction required</i>
	respectively limiting the extent of exposure of each of the plurality of superabrasive cutters perpendicular to the respective at least one formation-facing bearing surface proximate each of the plurality of superabrasive cutters to a selected cutter exposure height ('631 Patent, claims 43, 50)	<i>No construction required</i>
31	so as to effectively limit an amount of exposure of the at least one of the superabrasive cutters ('631 Patent, claim 10)	<i>AGREED- No construction required</i>
	so as to further limit the extent of exposure of the at least one of the superabrasive cutters ('631 Patent, claim 50)	
32	exterior hard facing ('631 Patent, claim 7)	wear-resistant material that is harder than the material onto which it is applied
	hard facing ('631 Patent, claim 10)	
	hard facing material ('631 Patent, claim 50, 78)	

33 built up with a hard facing ('631 Patent, claim 10) *No construction required*

	hard facing material to build up ('631 Patent, claim 50)	<i>No construction required</i>
34	without generating an excessive amount of torque-on-bit ('631 Patent, claim 33)	<i>No construction required.</i>
35	several ('631 Patent, claims 4, 42)	AGREED-Two or more

36 a superabrasive backrake angle of approximately 30 (deg.) ('631 Patent, claim 27) AGREED-The angle between the longitudinal axis of the cutter body of at least one superabrasive cutter and the formation to be engaged is about 30 degrees

37	substantially transverse to a direction of cutter movement during drilling ('249 Patent, claim 1)	AGREED-the cutting face of the cutter being positioned substantially perpendicular to the direction of cutter movement during drilling
----	---	--

38 with respect to a line generally perpendicular to the subterranean formation, as taken in the direction of intended bit rotation AGREED-with reference to a line placed perpendicular (at a ninety degree angle) to the formation to be cut by the cutter in the intended direction of drill bit rotation

	with respect to a line generally perpendicular to the formation, as taken in the direction of intended bit rotation ('715 Patent, claims 1, 52)	
--	---	--

39 face ('249 Patent, claim 1) ('715 Patent, claims 91, 94) AGREED-the surface on the leading end of the bit on which or over which the blades and/or cutters are located

face of the bit body ('249 Patent, claims 2, 10) ('715 Patent, claim 1, 2, 52, 91)

	bit body face ('249 Patent, claim 7)	
--	--------------------------------------	--

40 cutting face(s) ('249 Patent, claims 1, 4) ('715 Patent, claims 1, 62) AGREED-the portions of the cutter which may contact and "cut" the formation during drill bit rotation, including the center portion chamfer, if any, and sides of the cutter

41 cutting edge ('249 Patent, claim 1) AGREED-any part of the cutter that engages, contacts, cuts, or works, the formation being drilled

42 determined at least in part by cutter backrake angles of the cutters ('249 Patent, claim 8) AGREED-cutter backrake angle is at least one factor that contributes to the effective cutting face backrake angle for the cutter

43 cutting geometry characteristic ('715 Patent, claims 91, 92, 94, 95, 96) AGREED-includes the following characteristics or features of the cutters: cutter backrake angle; effective cutting face backrake angle; chamfer angle; chamfer width and chamfer backrake angle

44 a first range of cutter backrake angles ('715 Patent, AGREED-the extent or limits of variation of

	claim 57)	cutter backrake angles for cutters located inside the first region
45	a second range of cutter backrake angles ('715 Patent, claim 57)	AGREED-the extent or limits of variation of cutter backrake angles for cutters located inside the second region
46	a third range of cutter backrake angles ('715 Patent, claim 57)	AGREED-the extent or limits of variation of cutter backrake angles for cutters located inside the third region
47	preselected effective cutting face backrake angle(s) ('249 Patent, claim 1) ('715 Patent, claims 1, 52, 62)	AGREED-The effective cutting face backrake angle is selected before the cutter is mounted on the bit.
	a majority of cutters located in the second and third regions ('715 Patent, claims 1, 52)	AGREED-More than half of the cutters located in the second region and more than half of the cutters located in the third region.
48	selectively varying at least one of a cutter backrake angle, providing a cutting face having a preselected geometry comprising configuring the cutting face to include a chamfer of a preselected width and chamfer angle, and varying the respective cutting face angles in relation to the radial distance from the longitudinal axis in which the cutter bearing the respective cutting face is located ('715 Patent, claim 62)	AGREED-Selectively varying at least one of the cutter backrake angle, the selected or chosen chamfer width, the selected or chosen chamfer angle, or varying the cutting face angles of the cutters relative to the respective cutter's radial distance from the longitudinal axis of the bit measured perpendicular (at a ninety degree angle) to that axis.
49	chamfer angle ('715 Patent, claims 91, 94)	AGREED-The angle of the outer beveled portion of the cutter measured relative to the longitudinal axis of the cutter body.
50	chamfer width ('715 Patent, claims 91, 94)	AGREED-The width of the outer beveled portion of the cutter, measured perpendicular to the longitudinal axis of the cutter body.
51	formation ('0 Patent, claims 1, 17, 37, 42, 44, 47, 49, 52, 53, 54, 55, 56, 57) ('631 Patent, claims 1, 2, 25, 33, 34, 35, 36, 37, 38, 42, 43, 50, 51, 64, 66, 67, 78)	AGREED-a subterranean layer (or group of layers) of rock which extends entirely across the area under consideration. Formations may consist of single ledges or beds of rock, but are generally made up of two or more closely related beds.
52	wherein the bit body comprises at least one of a steel and a metal matrix ('631 Patent, claim 5)	AGREED-the body of the drill bit is made of steel or is made of a "matrix" or a mixture of metals (typically a mass of metal powder, such as tungsten carbide infiltrated with a molten, subsequently hardenable binder such as a copper-based alloy)
53	within a selected depth-of cut range ('631 Patent, claim 33)	AGREED-between selected upper and lower depth-of-cut limits
54	being positioned substantially transverse to a direction of cutter movement during drilling ('631 Patent, claim 64)	AGREED-the cutting face of the cutter being positioned substantially perpendicular to the direction of cutter movement during drilling

55	wherein a combination of bearing surfaces of bearing segments of the plurality exhibits the sufficient surface area ("0 Patent, claim 2)	AGREED-The combined surface area of the bearing segments is designed to provide the sufficient surface area.
56	wherein a combination of bearing surfaces of bearing segments of the plurality is sized and configured to provide the sufficient surface area ("0 Patent, claim 18)	AGREED-The combined surface area of the bearing segments is designed to provide the sufficient surface area.
57	the at least one superabrasive cutter exhibiting a limited amount of cutter exposure perpendicular to the selected portion of the face of the leading end to which the at least one superabrasive cutter is secured to, in combination with the total bearing surface of the bit body, limit a maximum depth-of-cut of the at least one superabrasive cutter into the formation having the maximum compressive strength during drilling ('631 Patent, claim 1)	AGREED-The at least one superabrasive cutter having a maximum depth-of-cut during drilling determined by its cutter exposure and the total bearing surface of the drill bit.
	"Cutter exposure": the distance measured perpendicularly from the part of the surface of the bit upon which such cutter is mounted to the highest point of the cutting face of the cutter.	
58	exhibit at least one bearing surface ('631 Patent, claim 4)	AGREED-Includes at least one surface designed to bear weight upon the formation
59	a limited portion of each of the several superabrasive cutters exposed by a preselected extent perpendicular from the respective at least one bearing surface proximate each of the several superabrasive cutters so as to control a respective depth-of-cut for each of the several superabrasive cutters ('631 Patent, claim 4)	AGREED-Each of the several superabrasive cutters has a preselected and limited cutter exposure to control each cutter's depth-of-cut during drilling.
60	exhibits a lesser amount of cutter exposure ('631 Patent, claim 13)	AGREED-Has a smaller cutter exposure
61	exhibits a greater amount of cutter exposure ('631 Patent, claim 14)	AGREED-Has a larger cutter exposure
62	each exhibiting a generally equal amount of cutter exposure perpendicular to the selected portion of the face of the leading end to which each of the plurality of superabrasive cutters is secured ('631 Patent, claim 31)	AGREED-Each of the superabrasive cutters in the plurality has generally the same cutter exposure.
63	providing at least one formation-facing bearing surface on the drill bit generally surrounding at least a portion of the at least one cutter ('631 Patent, claim 34)	AGREED-Providing a bearing surface on the face of the drill bit that generally surrounds at least a portion of the at least one cutter.
	limiting an extent of exposure of the at least one cutter generally perpendicular to the at least one formation-facing bearing surface ('631 Patent, claim 34)	AGREED-Limiting the cutter exposure of the at least one cutter.
64	each being limited to generally an equal amount of cutter exposure perpendicular to a selected portion of an outward face of a leading end to which each of the	AGREED-Each of the superabrasive cutters in the plurality has generally the same cutter exposure.

	plurality of superabrasive cutters is secured ('631 Patent, claim 39)	
65	wherein the at least one cutter exhibits a limited amount of cutter exposure perpendicular to a portion of the formation-facing surface to which the at least one cutter is secured to control a maximum depth-of-cut of the at least one cutter into the formation during drilling ('631 Patent, claim 64)	AGREED-The at least one cutter has a limited cutter exposure to control the cutter's maximum depth-of-cut during drilling.
66	wherein at least one cutter of the plurality secured on the bit body in the first region exhibits a limited amount of cutter exposure that is less than a limited amount of cutter exposure of at least one cutter of the plurality secured in the second region ('631 Patent, claim 69)	AGREED-At least one cutter mounted in the cone region of the bit is designed to have a smaller amount of cutter exposure than at least one of the cutters mounted in the nose, shoulder, or flank regions of the bit.
67	each exhibiting a generally equal amount of cutter exposure perpendicular to a selected portion of an outward face of a leading end to which each of the plurality of cutters is secured ('631 Patent, claim 82)	AGREED-Each of the cutters in the plurality has generally the same cutter exposure.

APPENDIX C COURT'S ANNOTATIONS OF CERTAIN FIGURES

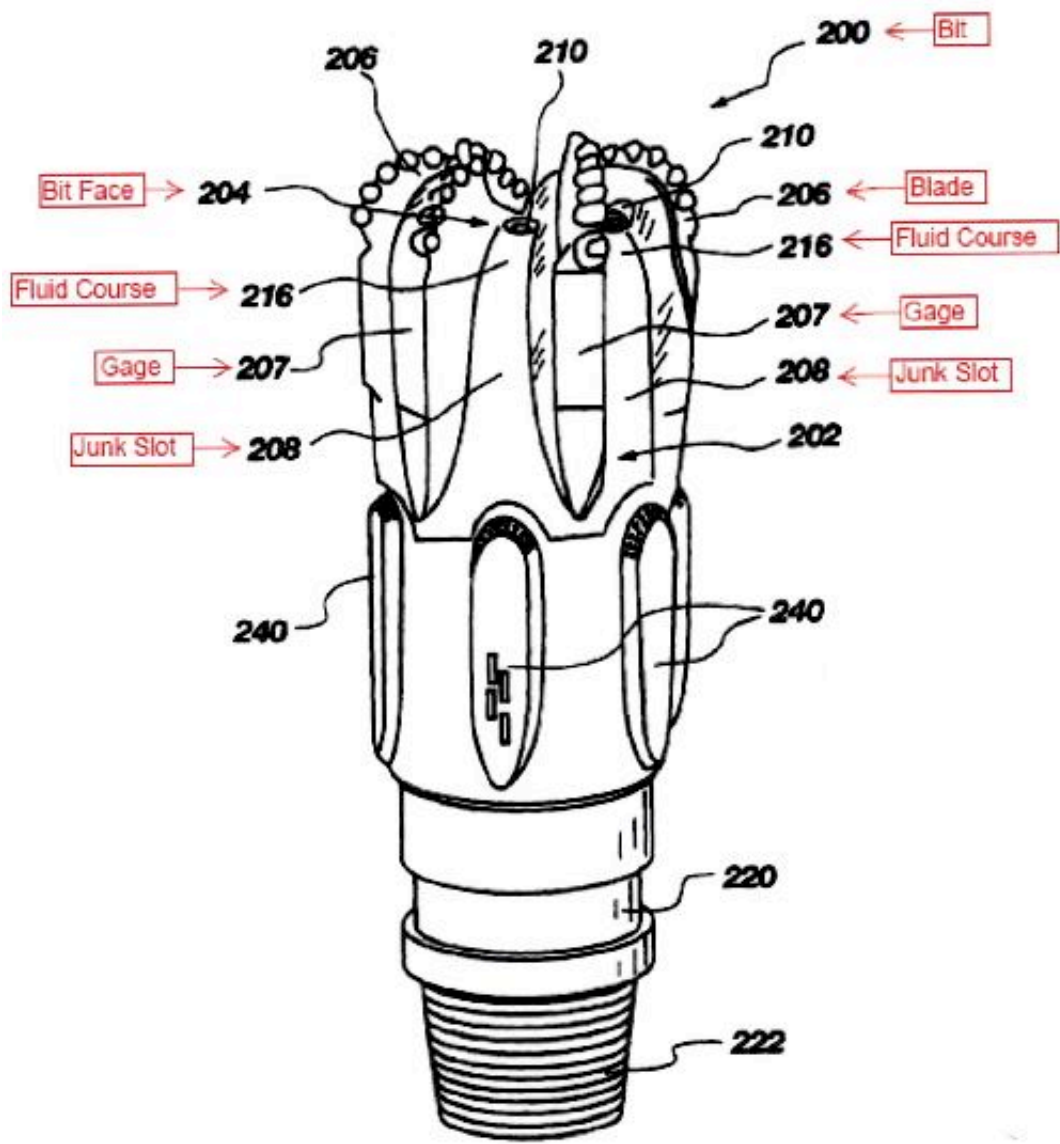

Fig. 7

'249 Patent Fig. 7; '715 Patents Fig. 7.

'249 Patent Fig. 10; '715 Patent Fig. 10.

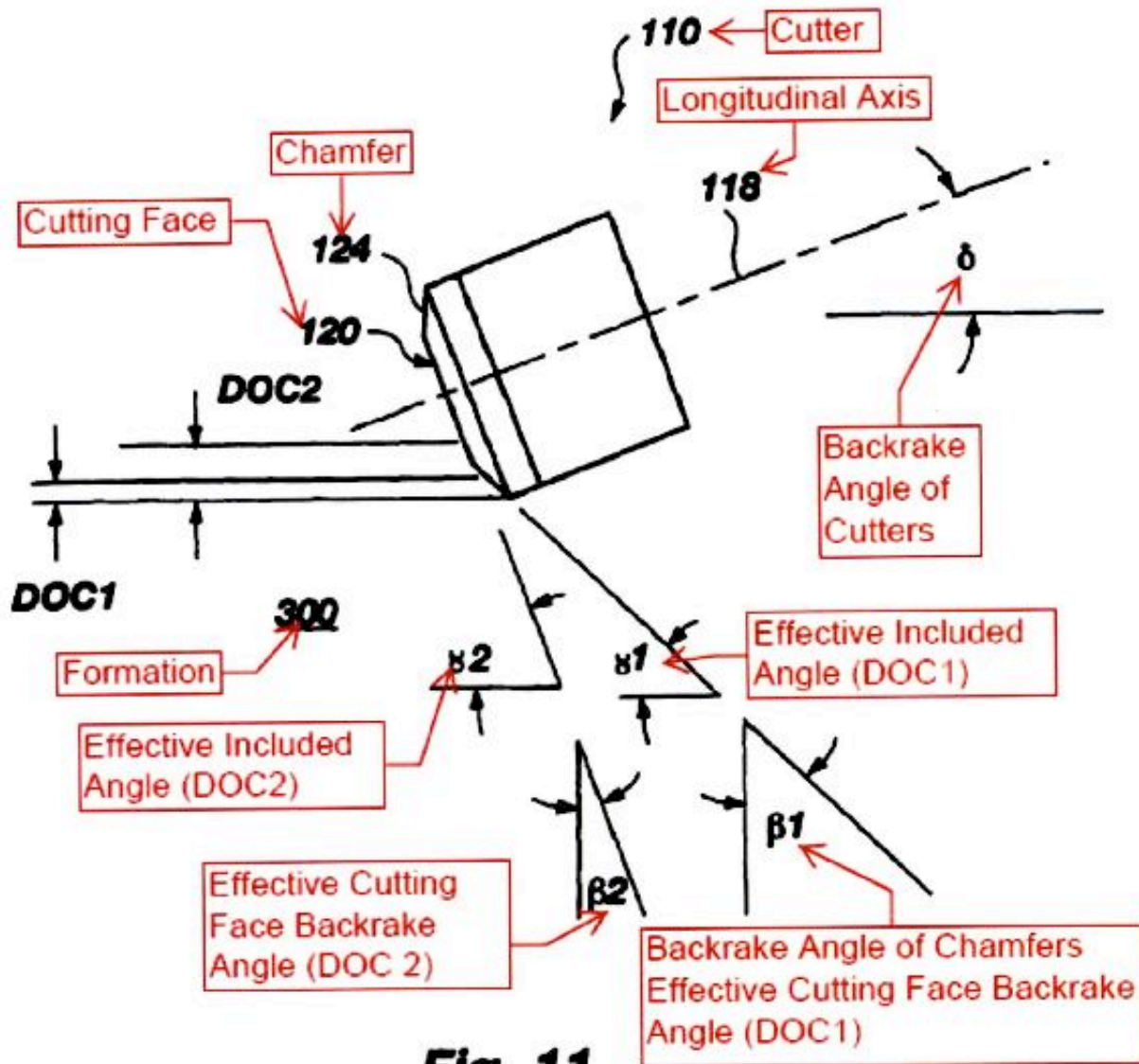

Fig. 11

'249 Patent Fig. 11.

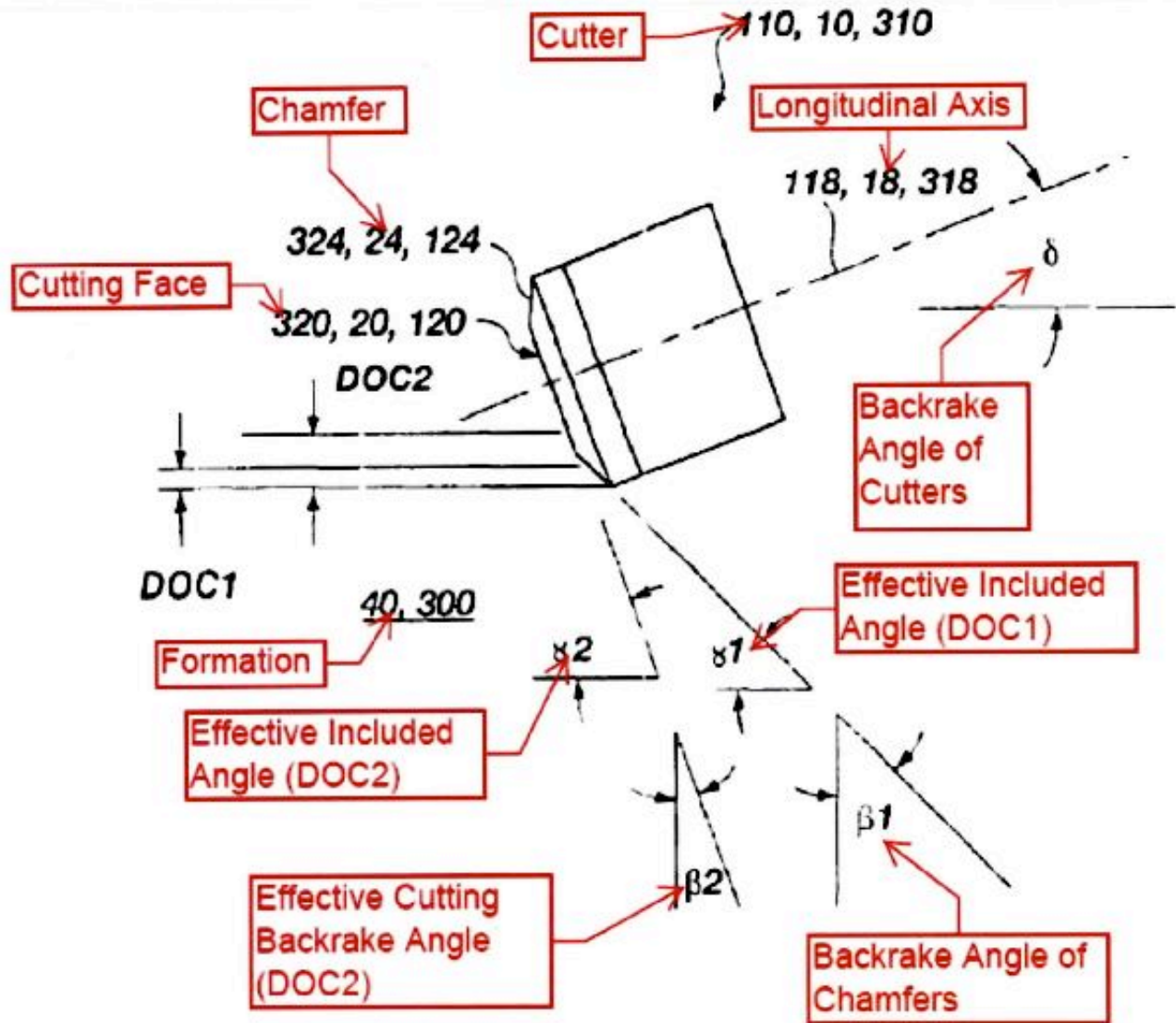

Fig. 11

'715 Patent Fig. 11.

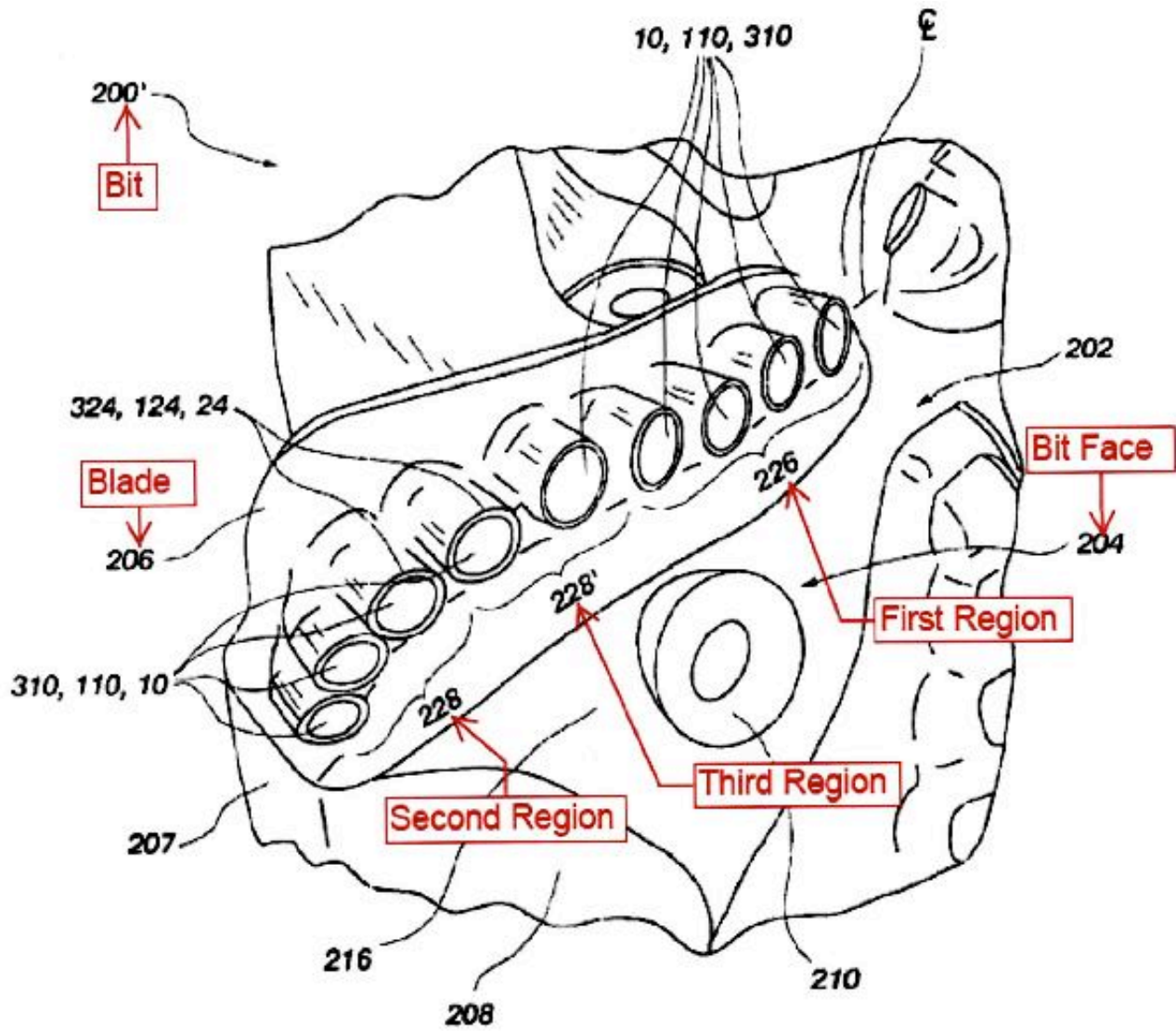

Fig. 12

'715 Patent Fig. 12.

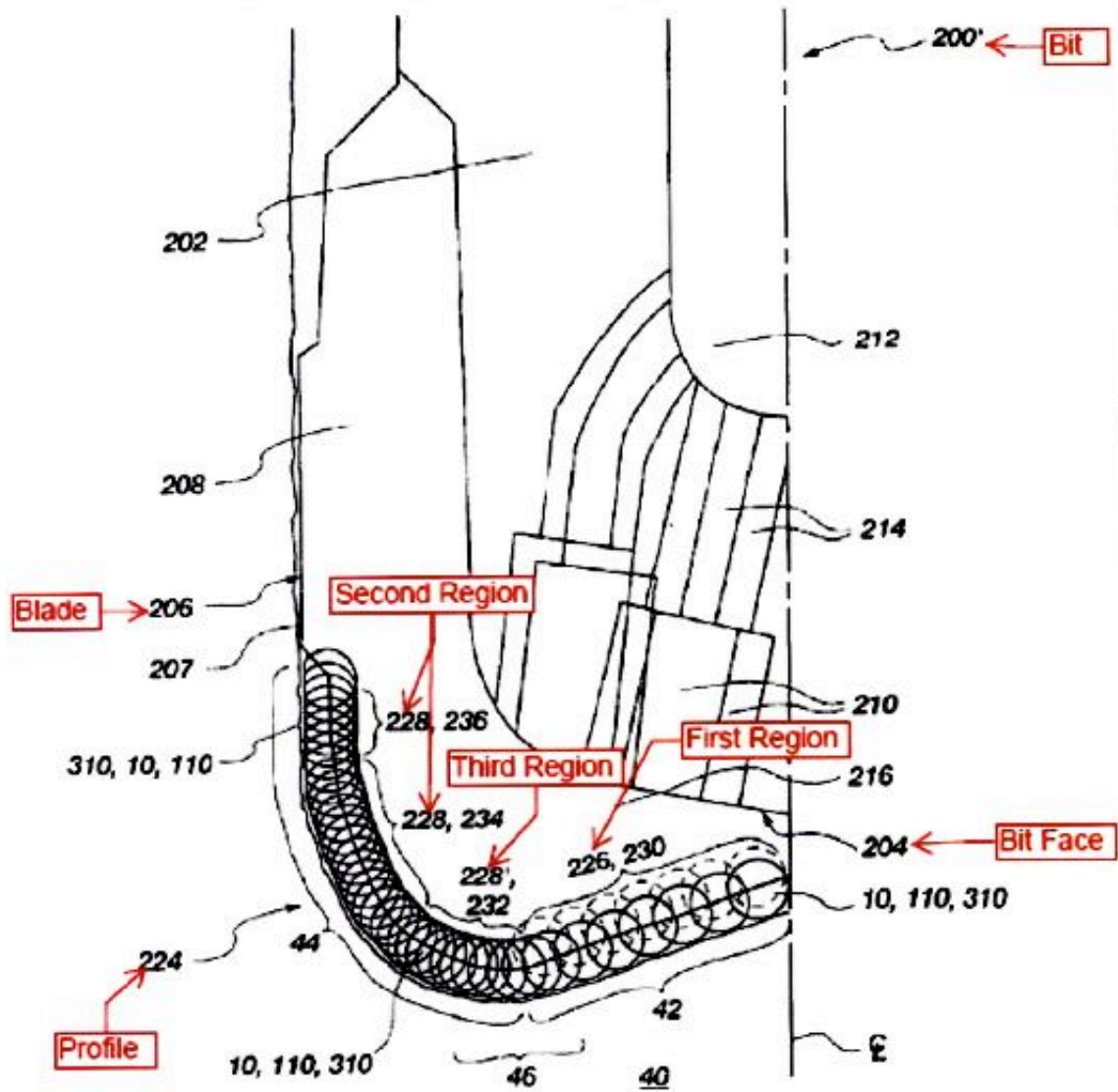
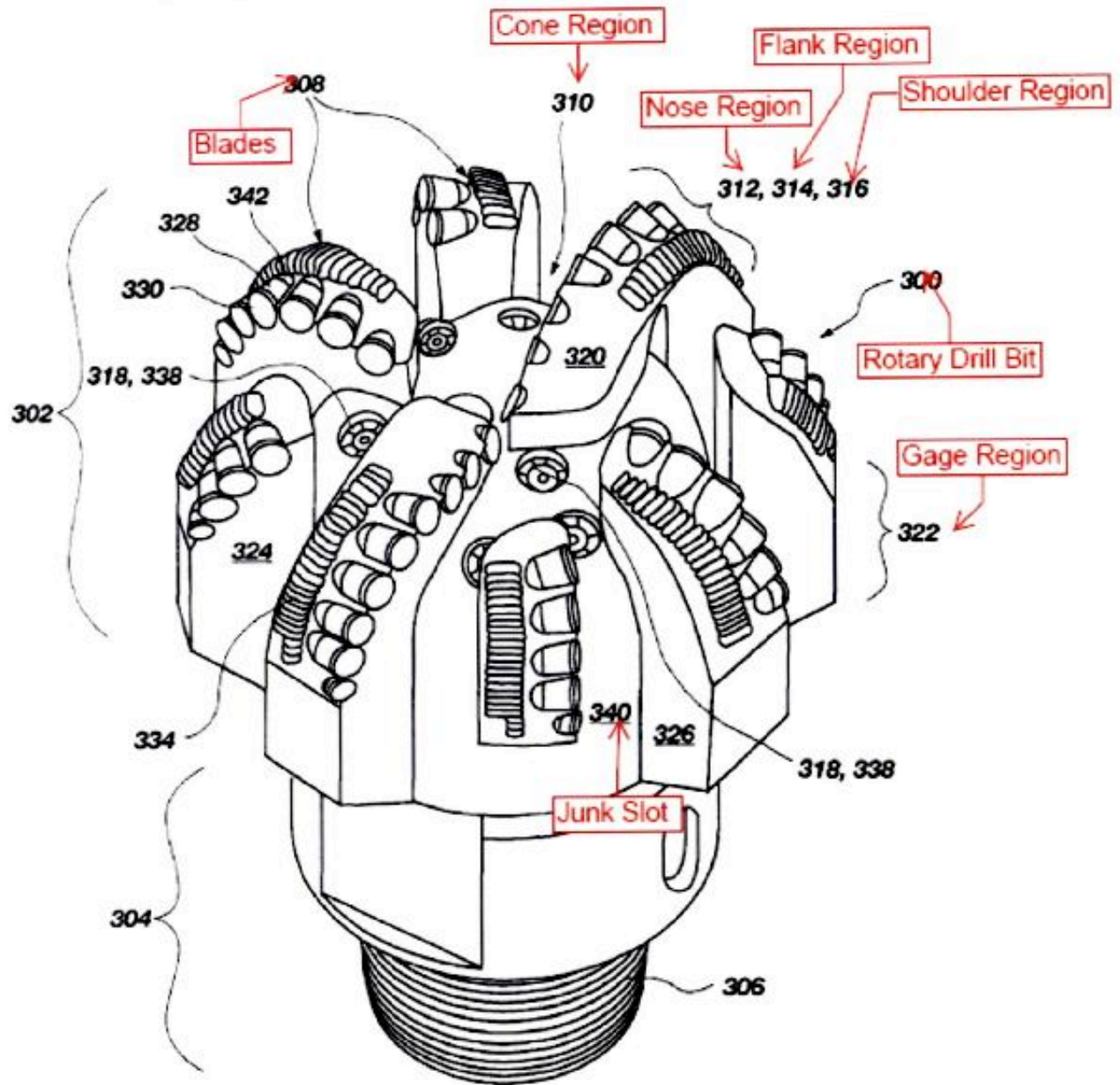

Fig. 13

'715 Patent Fig. 13.



'631 Patent Fig. 14A.

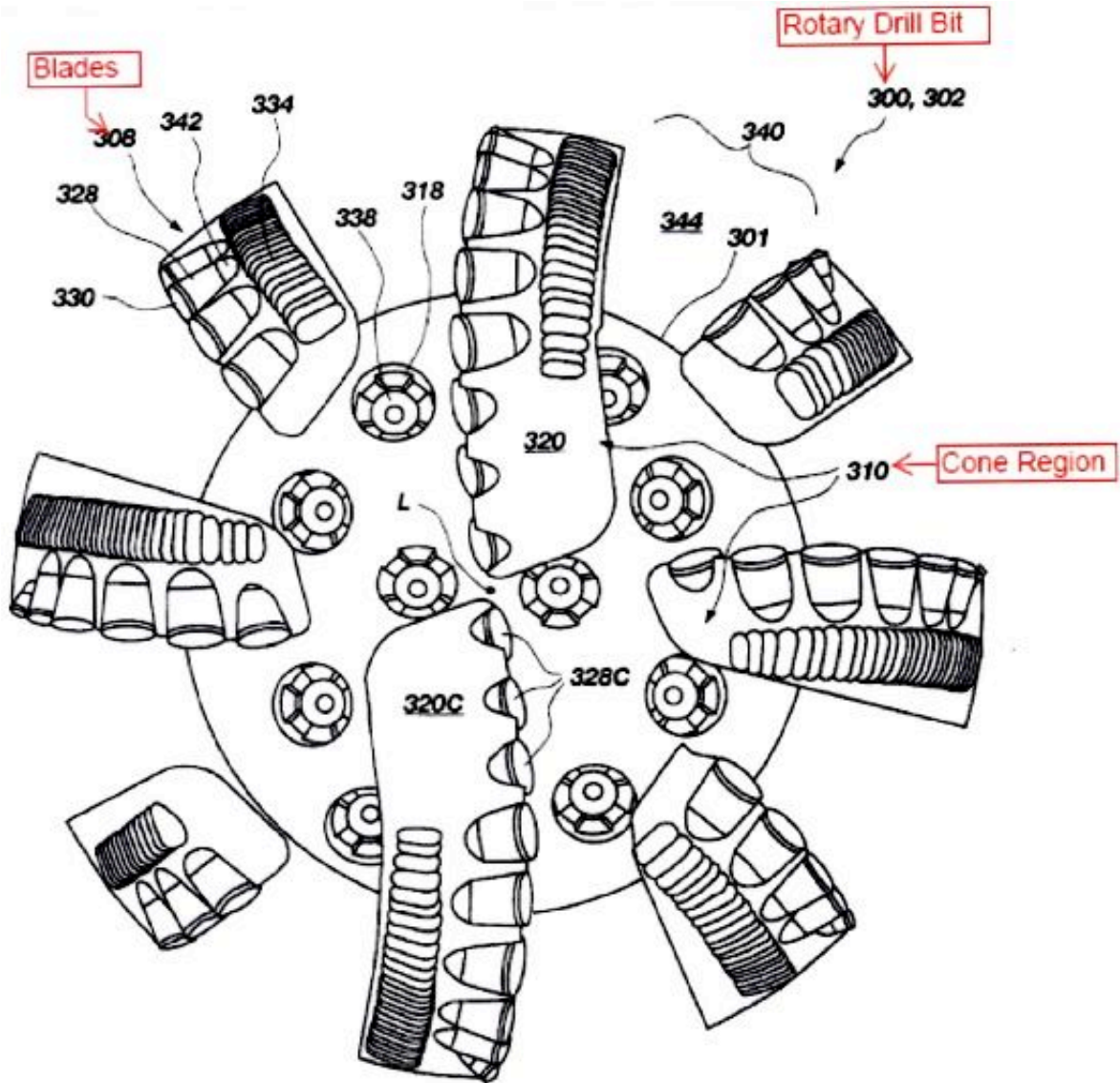

Fig. 14B

'631 Patent Fig. 14B.

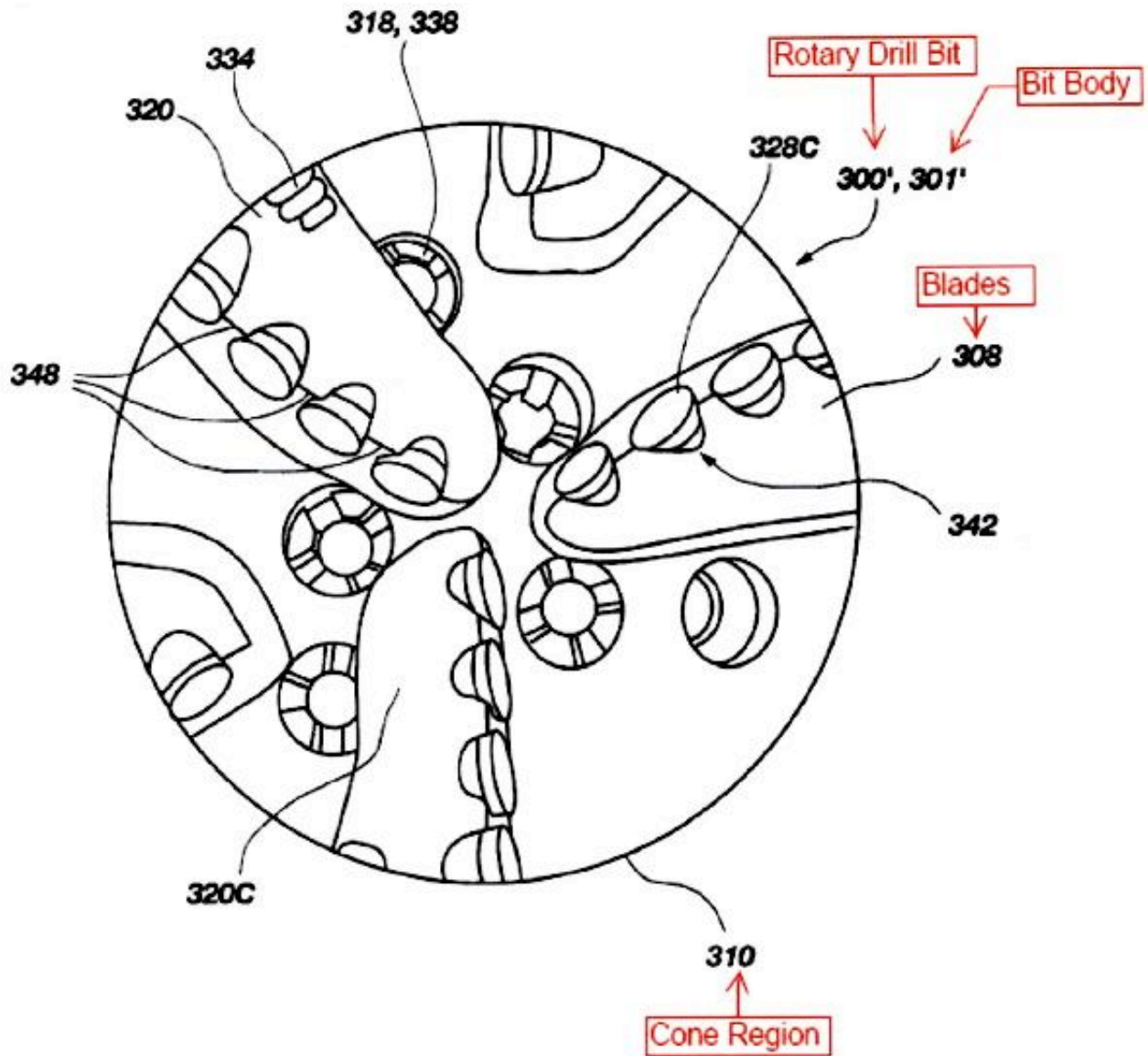
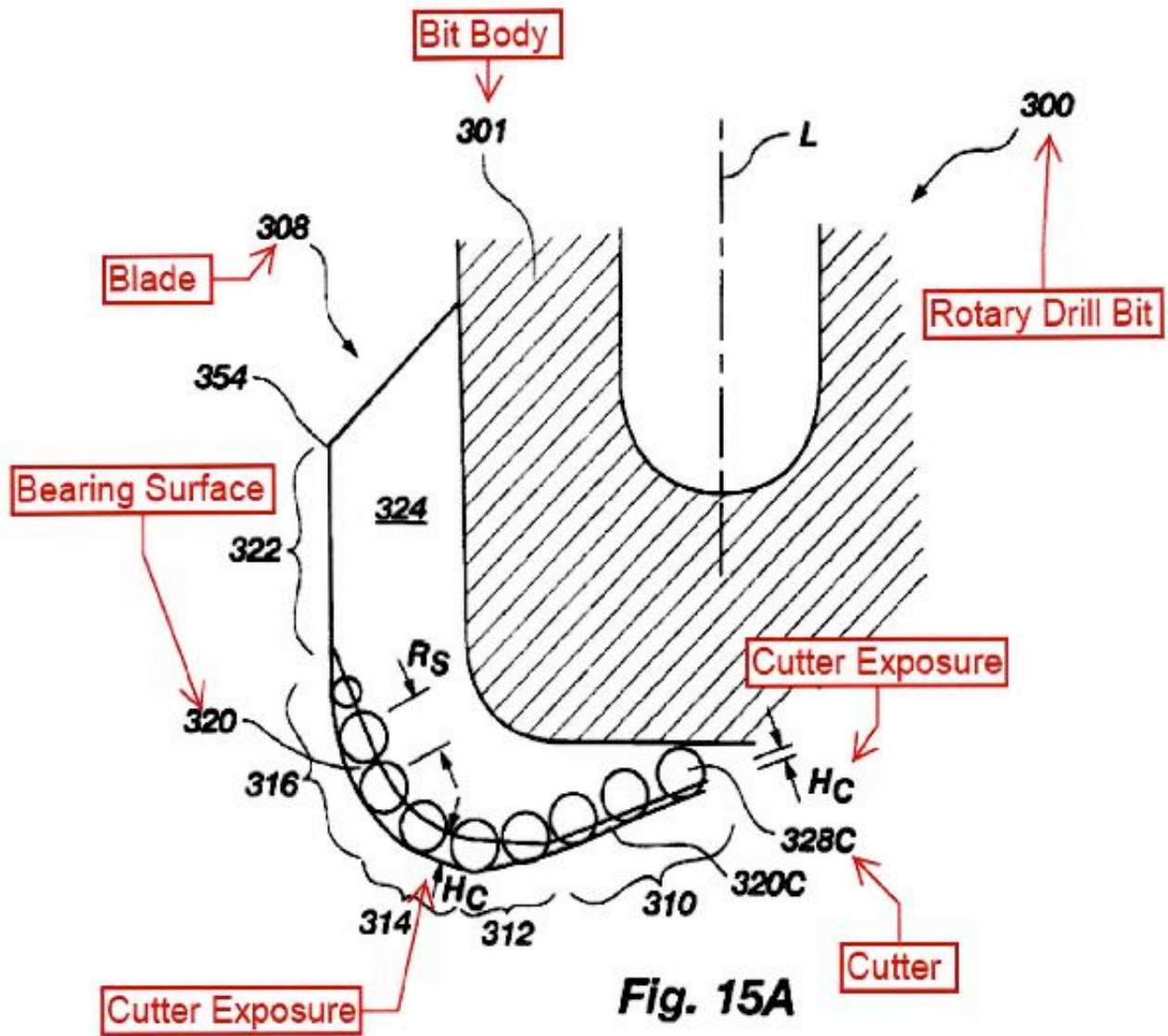

Fig. 14C

'631 Patent Fig. 14C.



'631 Patent Fig. 15A.

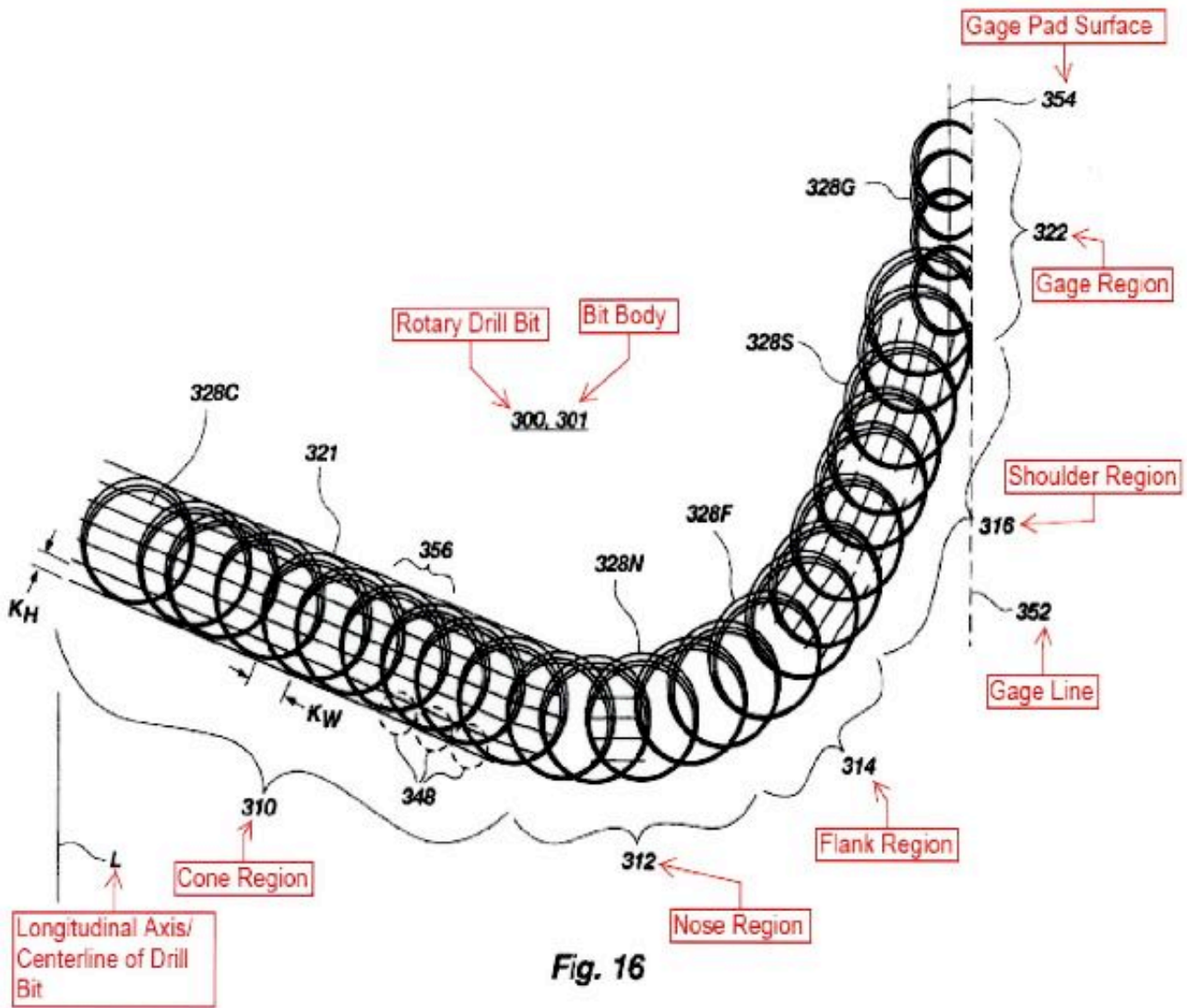
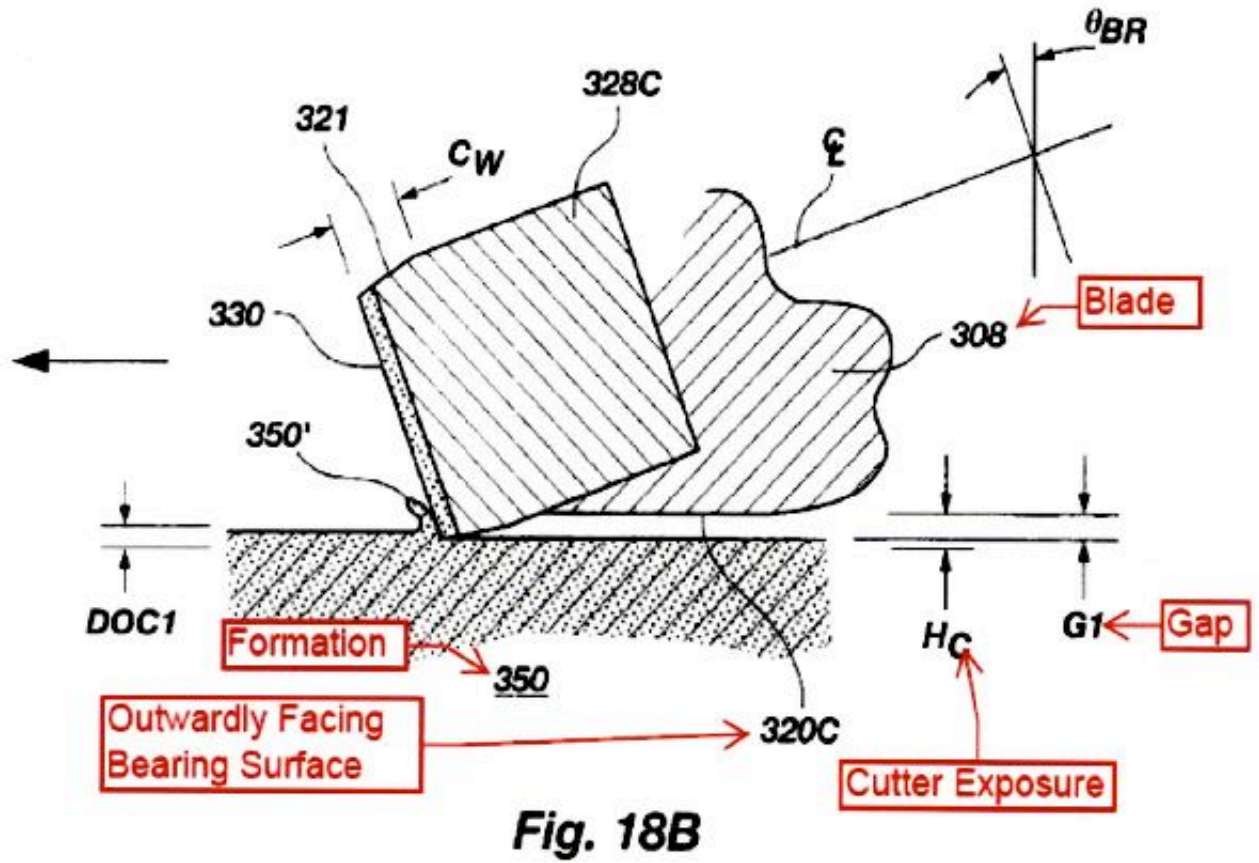

Fig. 16

'631 Patent Fig. 16.



'631 Patent Fig. 18B.

Produced by Sans Paper, LLC.