

United States District Court,  
E.D. Pennsylvania.

**BAUSCH & LOMB INCORPORATED,**  
Plaintiff.

v.

**MORIA S.A., et al,**  
Defendants.

**April 16, 2002.**

Memorandum Granting Reconsideration in Part Aug. 26, 2002.

Exclusive licensee of patents on surgical devices used to cut human cornea during laser eye surgery brought infringement action against competitor. Following *Markman* hearing on claim construction, the District Court, Lowell A. Reed, Jr., Senior District Judge, construed multiple claims and held that: (1) language of claim preambles which ended with phrases such as "cutting blade assembly comprising" was limiting with reference to claims; (2) court would not construe claim to correct alleged typographical error; and, on motion for reconsideration, (3) term "guide element" would be given same construction as terms "guide means" and "guide assembly."

Ordered accordingly.

5,624,456, 6,007,553, 6,051,009, 6,296,649. Construed.

Andrew J. Mottes, Gary A. Rosen, Elke F. Suber, Akin, Gump, Strauss, Hauer & Feld, L.L.P., Philadelphia, PA, Lester L. Hewitt, Gregory M. Hasley, Akin Gump, Strauss, Hauer & Feld, Houston, TX, David R. Clontis, Akin, Gump, Haver, Houston, TX, for plaintiffs.

Christopher K. Walters, Reed, Smith, Shaw & McClay, Philadelphia, PA, Cari S. Nadler, Heller, Ehrman, White & McAuliffe, Washington, DC, for defendants.

***CONCLUSIONS OF LAW REGARDING PATENT CLAIM CONSTRUCTION***

**LOWELL A. REED, JR., Senior District Judge.**

***TABLE OF CONTENTS***

	<i>page</i>
<b>I. THE LAW OF PATENT CLAIM CONSTRUCTION</b>	626
<b>A. Claim Language</b>	627
<b>B. Specification</b>	627

<b>C.</b>	<b>Prosecution History</b>	628
<b>D.</b>	<b>Extrinsic Evidence</b>	629
<b>E.</b>	<b>Means-Plus-Function Limitations</b>	630
<b>II.</b>	<b>CONSTRUCTION OF THE CLAIMS</b>	632
<b>A.</b>	<b>Guide Means, Guide Assembly and Guide Element</b>	632
<b>B.</b>	<b>Drive Means and Drive Assembly</b>	640
<b>C.</b>	<b>Coupling Member</b>	644
<b>D.</b>	<b>Reserve Vacuum Assembly</b>	646
<b>E.</b>	<b>Nose Segment</b>	647
<b>F.</b>	<b>Preambles</b>	648
<b>G.</b>	<b>Remaining Claim Terms not Addressed at Oral Argument</b>	649
1.	<b>Claim 52 of the '456 Patent</b>	650
2.	<b>Means for Temporary Attachment</b>	650
3.	<b>At least Partially Received</b>	651
4.	<b>Means for Permitting Movement</b>	651
5.	<b>Channel Member</b>	652
6.	<b>Generally Tear Drop Shape</b>	653
7.	<b>Generally Vertical Orientation</b>	653
8.	<b>Access Means for Accessing</b>	654
9.	<b>Worm Gear</b>	655
10.	<b>Means for Retaining and Positioning</b>	655
11.	<b>If Said Operation of Said Vacuum Pump is Interrupted</b>	656

<b>12. Rear Edge</b>	657
<b>13. Generally Vertical Plane</b>	657

<b>III. CONCLUSION</b>	658
------------------------	-----

*APPENDIX*

<b>FIGURES 5A, 5B, 5C and 6 of the '456 Patent</b>	659
<b>FIGURE 7 of the '456 Patent</b>	660
<b>FIGURE 8 of the '456 Patent</b>	661
<b>FIGURE 11 of the '456 Patent</b>	662
<b>FIGURE 6-B of the '009 Patent</b>	663
<b>FIGURE 7 of the '009 Patent</b>	663
<b>FIGURE 11 of the '553 Patent</b>	664
<b>Front page of the '456 Patent</b>	665
<b>Front page of the '553 Patent</b>	666
<b>Front page of the '009 Patent</b>	667
<b>Front page of the '649 Patent</b>	668

Johann F. "Hans" Hellenkamp is the holder of four United States patents dealing with surgical devices used to cut the human cornea during the performance of laser eye surgery ("Hellenkamp patents" or "microkeratome patents"). Plaintiff Bausch & Lomb Incorporated ("B & L"), the exclusive licensee of the Hellenkamp patents, filed this patent infringement suit against Moria S.A. ("Moria") and Microtech, Inc. ("Microtech") alleging that defendants are infringing the Hellenkamp patents. In total, twenty patent claims are at issue in this lawsuit. Those claims include Claims 1(a), 1(b), 1(c), 1(d), 1(e), 6, 7, 18, 21, 42, 48(c), 48(d), and 52 of the 5,624,456 patent ("the '456 patent"), Claim 14 of the 6,007,553 patent ("the '553 patent"), Claims 30(b), 30(d), 34(a), 54(b), 67(b), as well as specified preambles to Claims 34, 53, 54, 55 and 67 of the 6,051,009 patent ("the '009 patent"), and Claims 3(b), 3(d), 9(b), 9(d), 10(b), 10(e), 14(b), 15(b), and 15(d) of the 6,296,649 B1 patent ("the '649 patent"). FN1

FN1. The parties also presented briefing on terms recited in the following claims: 1(c), 8, 9, 19, 41 and 48(a) of the '456 patent, 14 and 34(c) of the '553 patent, 30(a), 30(e), 34(a) and 53 of the '009 patent, and 3(a), 9(a), 10(a), 14(a) and 15(a) of the '649 patent.

A *Markman* hearing was held on December 18, 2001, in which the parties presented oral argument as to the proper construction of the disputed claim language in the claims at issue. The parties also submitted a series of briefs, expert reports and deposition transcripts and proposed claim constructions to the Court, all of which were considered by this Court in making the claim constructions that follow. On each claim term to be construed, the parties have submitted many arguments and have pointed to many portions of the intrinsic and extrinsic record in their briefs, proposed claim constructions, and oral presentations. While the Court has considered all of the arguments and citations of the parties, I may not reiterate all of them in full for each claim term.

## I. THE LAW OF PATENT CLAIM CONSTRUCTION

In general, a patent must describe the scope of the patentee's invention so as to "secure to [the patentee] all to which he is entitled, [and] to apprise the public of what is still open to them." *Markman v. Westview Instruments, Inc.*, 517 U.S. 370, 373, 116 S.Ct. 1384, 134 L.Ed.2d 577 (1996) (internal quotation omitted) (alteration in original). This is accomplished through the specification of the patent, which should describe the invention in clear terms so that a person of ordinary skill in the art FN2 of the patent may make and use the invention, and the claims of the patent, which should "particularly point[ ] out and distinctly claim[ ] the subject matter which the applicant regards as his invention." 35 U.S.C. s. 112.

FN2. The parties have stipulated that:

[F]or the purposes of the *Markman* proceeding, a person of ordinary skill in the art as of the time of the filing date from which a claim derives priority of each of the patent applications which issued as patents in this case was an educated mechanical design engineer or a physician, either of whom having a number of years of experience in the design of precision mechanical devices for cutting the eye.

(Pl.'s Ex. 38.)

[1] [2] [3] In *Markman*, the Supreme Court, affirming the Court of Appeals for the Federal Circuit, held that construction of patent claims is exclusively within the province of the court to determine as a matter of law. 517 U.S. at 372, 116 S.Ct. 1384. To complete the task of claim construction, a court may draw on the canons of construction that can be sifted from the decisions of the Court of Appeals for the Federal Circuit spanning before *Markman* and beyond. In construing the claims of a patent, a court should consider the claim language, the specification, and, if offered, the prosecution history, which are collectively considered intrinsic evidence of the meaning of the claim terms. *See Markman v. Westview Instruments, Inc.*, 52 F.3d 967, 979 (Fed.Cir.1995). As the public record before the United States Patent and Trademark Office ("PTO") upon which the public is entitled to rely, the intrinsic evidence is the most important source for determining the meaning of claim terms. *See Vitronics Corporation v. Conceptronic, Inc.*, 90 F.3d 1576, 1582-83 (Fed.Cir.1996). Under some circumstances, a court may also consult evidence extrinsic to the patent, such as technical dictionaries or expert testimony, to interpret the claims. *See id.* at 1583.

### A. Claim Language

[4] [5] [6] [7] [8] Claim construction begins by looking to the claim language itself to define the scope of the patent. *See Bell Atlantic Network Serv., Inc. v. Covad Comm. Group, Inc.*, 262 F.3d 1258, 1267 (Fed.Cir.2001). A technical term used in a patent is construed as having "the meaning a person of ordinary skill in the field of the invention would understand it to mean." *Id.* Unless otherwise compelled, a court should give full effect to the ordinary meaning of claim terms, even if the terms are broad. *See Johnson Worldwide Assoc., Inc. v. Zebco Corporation*, 175 F.3d 985, 989 (Fed.Cir.1999). "General descriptive terms will ordinarily be given their full meaning; modifiers will not be added to broad terms standing alone." *Id.*

Where the claim language is clear on its face, the remaining intrinsic evidence is considered only to determine whether a deviation from that clear definition is specified. *See Interactive Gift Express, Inc. v. Compuserve Inc.*, 256 F.3d 1323, 1331 (Fed.Cir.2001). Where the language lacks clarity, then the remaining intrinsic evidence is viewed for resolving that ambiguity. *See id.*

## ***B. Specification***

[9] [10] After examining the words of the claim, the court is directed to turn to the specification to determine whether any terms have been used in a manner which is inconsistent with the ordinary meaning. *See Vitronics*, 90 F.3d at 1582. While terms are generally given their ordinary meaning, "[c]laims must be read in view of the specification, of which they are a part." *Markman*, 52 F.3d at 979; *see also Phonometrics, Inc. v. Northern Telecom Inc.*, 133 F.3d 1459, 1466 (Fed.Cir.1998) ("Although claims are not necessarily restricted in scope to what is shown in a preferred embodiment, neither are the specifics of the preferred embodiment irrelevant to the correct meaning of claim limitations."). The relationship between the claims and the specification is illustrated by the following pair of claim construction canons: "(a) one may not read a limitation into a claim from the written description, but (b) one may look to the written description to define a term already in a claim limitation, for a claim must be read in view of the specification of which it is a part." *Renishaw PLC v. Marposs Societa' per Azioni*, 158 F.3d 1243, 1248 (Fed.Cir.1998). At times, the line between reading a claim in light of its specification and reading a limitation into the claim from the specification is a fine one. *See Interactive Gift*, 256 F.3d at 1331. Thus, this Court is mindful that the specification is examined to discern the meaning of the claim as used by the patentee in the context of the entire invention and not merely to narrow the claim. *See id.*

[11] [12] While additional limitations may not be imported into a claim from the specification, a court may construe a limitation specifically recited in a claim in light of the specification. *See Phonometrics*, 133 F.3d at 1466. Thus, in order to inject a definition into a claim from the written description, the claim must explicitly contain a term in need of definition. *See Renishaw*, 158 F.3d at 1248, 1252 (noting that passages referring to the preferred embodiment cannot be read into the claim without some "hook"). Further, claim terms should not be narrowed by the content of the specification "unless the language of the claims invites reference to those sources." *Johnson Worldwide*, 175 F.3d at 990 (noting that there "must be a textual reference in the actual language of the claim with which to associate a proffered claim construction").

[13] [14] While there is a "heavy presumption" in favor of giving terms their ordinary meaning, the presumption can be overcome if (1) the patentee chooses to be his own lexicographer, or (2) a claim term so deprives the claim of clarity that there is " 'no means by which the scope of the claim may be ascertained from the language used.' " *Bell Atlantic*, 262 F.3d at 1268 (quoting *Johnson Worldwide Assoc., Inc. v. Zebco Corp.*, 175 F.3d 985, 989 (Fed.Cir.1999)). In the first situation, the court must examine intrinsic evidence to determine if the patentee gave a term an extraordinary meaning. *See id.* The specification will act as a dictionary " 'when it expressly defines terms used in the claims or when it defines terms by implication.' " *Id.* (quoting *Vitronics*, 90 F.3d at 1582). Thus, the specification is "highly relevant" and usually "dispositive" in construing claim terms. *Id.*

The Federal Circuit has indicated that where the specification is used to redefine the meaning of a particular term, the intrinsic evidence must " 'clearly set forth' " or " 'clearly redefine' " the term in such a way that one reasonably skilled in the art is on notice that the patentee intended such redefinition. *Bell Atlantic*, 262 F.3d at 1268 (quoting *Elekta Instr. v. O.U.R. Scientific Int'l*, 214 F.3d 1302, 1307 (Fed.Cir.2000); *N. Telecom v. Samsung*, 215 F.3d 1281, 1287 (Fed.Cir.2000)). The Court of Appeals has further provided that the written description must demonstrate an " 'express intent to impart a novel meaning' to claim terms." *Id.* (quoting *Schering Corp. v. Amgen Inc.*, 222 F.3d 1347, 1353 (Fed.Cir.2000); *Optical Disc Corp. v. Del Mar Avionics*, 208 F.3d 1324, 1334 (Fed.Cir.2000)). At the same time, the Federal Circuit has also determined that an "explicit statement of redefinition" is unnecessary; the specification may define claim terms " 'by

implication' " in that the meaning is " 'found in or ascertained by a reading of the patent documents.' " *Id.* (quoting *Vitronics*, 90 F.3d at 1582, 1584 n. 6). *Cf.* *Johnson Worldwide*, 175 F.3d at 991 (term used in a variety of ways in specification may be indicative of breadth of term rather than a limited definition).

[15] As to the second situation which may overcome a presumption that the term be construed to have its ordinary meaning, while a court generally construes claim terms consistent with their common meaning, a "common meaning, such as one expressed in a relevant dictionary, that flies in the face of the patent disclosure is undeserving of fealty." *Renishaw*, 158 F.3d at 1250. Also, a court may resort to the specifications if a claim term lends itself to several common meanings; in such a situation "the patent disclosure serves to point away from the improper meanings and toward the proper meaning." *Id.*

### ***C. Prosecution History***

[16] This Court is also instructed to view the prosecution history to determine whether "the patentee has relinquished a potential claim construction in an amendment to the claim or in an argument to overcome or distinguish a reference." *Bell Atlantic*, 262 F.3d at 1268. This history encompasses the entire record of all proceedings before the PTO, including express representations made by the patentee regarding the scope of the patent, as well as prior art cited therein which may give clues as to what the claims do not cover. *See id.*; *Vitronics*, 90 F.3d at 1582-83. Thus this information can be of "critical significance" in construing the claims. *Vitronics*, 90 F.3d at 1582.

[17] [18] [19] As with the specification, however, "[a]lthough the prosecution history can and should be used to understand the language used in the claims, it too cannot 'enlarge, diminish, or vary' the limitations in the claims." *Markman*, 52 F.3d at 980 (quoting *Goodyear Dental Vulcanite Co. v. Davis*, 102 U.S. 222, 227, 12 Otto 222, 26 L.Ed. 149 (1880)). If a patentee takes a position before the PTO, such that a "competitor would reasonably believe that the applicant had surrendered the relevant subject matter," the patentee may be barred from asserting an inconsistent position on claim construction. *Cybor Corp. v. FAS Tech., Inc.*, 138 F.3d 1448, 1457 (Fed.Cir.1998); *see also* *Cole v. Kimberly-Clark Corp.*, 102 F.3d 524, 531 (Fed.Cir.1996) (holding that patentee was estopped from arguing that her "perforation means" encompassed "ultrasonic bonded seams" after she distinguished references that contained such seams). If a patentee distinguishes a reference on multiple grounds to the PTO, any one of these may indicate the correct construction of a term. *See Gentry Gallery, Inc. v. Berkline Corp.*, 134 F.3d 1473, 1477 n. \* (Fed.Cir.1998). However, "[u]nless altering claim language to escape an examiner[']s rejection, a patent applicant only limits claims during prosecution by clearly disavowing claim coverage," that is, by making a statement that concedes or disclaims coverage of the claims at issue based on a piece of prior art. *York Products, Inc. v. Central Tractor Farm & Family Ctr.*, 99 F.3d 1568, 1575 (Fed.Cir.1996).

### ***D. Extrinsic Evidence***

[20] [21] [22] If the claims can be construed from the intrinsic evidence alone, it is not proper to rely on extrinsic evidence "other than that used to ascertain the ordinary meaning of the claim limitation." *Bell Atlantic*, 262 F.3d at 1258. In the rare circumstance that the court is not able to construe the claims after examining the intrinsic evidence, however, it may turn to extrinsic evidence to resolve any ambiguity. *See id.* Extrinsic evidence includes expert testimony, articles and testimony of the inventor. *See id.* As with the intrinsic evidence, extrinsic evidence may not be used to "vary, contradict, expand, or limit the claim language from how it is defined, even by implication, in the specification or file history." *Id.* It is also proper to consult extrinsic evidence for the purpose of understanding the underlying technology. *See Interactive Gift*, 256 F.3d at 1332.

[23] Dictionaries and technical treatises, while they are technically extrinsic to the patent, hold a "special place" and in certain situations may be considered along with intrinsic evidence when determining the

ordinary meaning of claim terms. *Bell Atlantic*, 262 F.3d at 1267. *See also* *Dow Chem. Co. v. Sumitomo Chem. Co., Ltd.*, 257 F.3d 1364, 1372 (Fed.Cir.2001); *Vitronics Corp. v. Conceptronic, Inc.*, 90 F.3d 1576, 1584 n. 6 (Fed.Cir.1996) ("Judges are free to consult such resources at any time in order to better understand the underlying technology and may also rely on dictionaries definitions when construing term claims, so long as the dictionary definition does not contradict any definition found in or ascertained by a reading of the patent documents."). Courts are warned, however, against using non-scientific dictionaries, "lest dictionary definitions ... be converted into technical terms of art having legal, not linguistic significance." *Sumitomo*, 257 F.3d at 1372.

### ***E. Means-Plus-Function Limitation***

An element in a claim for a combination may be expressed as a means or step for performing a specified function without the recital of structure, material, or acts in support thereof, and such claim shall be construed to cover the corresponding structure, material, or acts described in the specification and equivalents thereof.

Thus, this paragraph restricts claim limitations drafted in such functional language to those structures (and their equivalents) that perform the claimed function. *See* *Personalized Media Communications, LLC v. Int'l Trade Comm'n*, 161 F.3d 696, 703 (Fed.Cir.1998). It allows a patentee to write a combination claim as a means for performing a function without reciting structure, material, or acts in the limitation; however, in order to invoke this drafting tool, the applicant must describe in the specification some structure which performs the specified function. *See* *Valmont Indus., Inc. v. Reinke Mfg. Co., Inc.*, 983 F.2d 1039, 1042 (Fed.Cir.1993).

[25] [26] If a patentee uses the word "means" in a claim, a presumption arises that he or she used the word to invoke s. 112, para. 6. *See* *Rodime PLC v. Seagate Tech., Inc.*, 174 F.3d 1294, 1302 (Fed.Cir.1999). There are two ways this presumption may be rebutted: (1) if a claim term uses the word "means" but recites no function which corresponds, or (2) if the claim recites a function but also recites sufficient structure or material for performing the claimed function. *See id.* Conversely, where a claim does not use the word "means," treatment as a means-plus-function claim is generally improper. *See* *Al- Site Corp. v. VSI Int'l, Inc.*, 174 F.3d 1308, 1318 (Fed.Cir.1999). Where, however, it is apparent that the element invokes "purely functional terms" without "recital of specific structure or material for performing that function," the claim element may nonetheless be a means-plus-function element even though the trigger word is absent. *Id.*

[27] Even if a mechanism is defined in functional terms, such as a "filter," "brake," "clamp," or "detent mechanism," or if it does not call to mind a single well-defined structure, it may not be subject to means-plus-function analysis. *See* *Greenberg v. Ethicon Endo-Surgery, Inc.*, 91 F.3d 1580, 1583 (Fed.Cir.1996) (noting that "[d]ictionary definitions make clear that the noun 'detent' denotes a type of device with a generally understood meaning in the mechanical arts, even though the definitions are expressed in functional terms" and that "[i]t is true that the term 'detent' does not call to mind a single well-defined structure, but the same could be said of other commonplace structural terms such as 'clamp' or 'container' "). In addition, a structural term need not connote a precise physical structure to those of ordinary skill in the art to avoid a means-plus-function analysis, as long as it conveys a variety of structures that are referred to by that term. *See* *Personalized Media*, 161 F.3d at 704-705 (noting that "detector" was not a generic structural term such as "means," "element," or "device" nor a coined term such as "widget" or "ram-a-fram" in deciding that use of the term "digital detector" did not subject the limitation to s. 112, para. 6 analysis).

[28] [29] The critical inquiry is "not simply that a [mechanism] is defined in terms of what it does, but that the term, as the name for structure, has a reasonably well understood meaning in the art." *Greenberg*, 91 F.3d at 1583. "[T]he focus remains on whether the claim as properly construed recites sufficiently definite

structure to avoid the ambit of s. 112, para. 6." *Personalized Media*, 161 F.3d at 704. The determination of whether or not s. 112, para. 6 applies is decided on an "element-by-element basis," based on the patent and its prosecution history. *Cole v. Kimberly-Clark Corp.*, 102 F.3d 524, 531 (Fed.Cir.1996) (citing *Palumbo v. Don-Joy Co.*, 762 F.2d 969 (Fed.Cir.1985), *overruled on other grounds*, *Markman*, 52 F.3d at 979 ("In construing a 'means plus function' claim, as also other types of claims, a number of factors may be considered, including the language of the claim, the patent specification, the prosecution history of the patent, other claims in the patent, and expert testimony")). If the court determines that a claim limitation is written in means-plus-function form, the court must define what the "means" are in the claim.

[30] [31] [32] The first step is to determine what function the claimed means performs. *See Rodime*, 174 F.3d at 1302. The claim language must link the term "means" to a function or the limitation is not subject to s. 112, para. 6. *See York Products*, 99 F.3d at 1574. The function must be specifically recited in the actual claim; the court must exercise great caution to prevent impermissibly adopting a function other than that explicitly recited in the claim. *See Generation II Orthotics Inc. v. Medical Tech. Inc.*, 263 F.3d 1356, 1363, 1365-66 (Fed.Cir.2001); *Micro Chem., Inc. v. Great Plains Chem. Co., Inc.*, 194 F.3d 1250, 1258 (Fed.Cir.1999). Thus, in construing means plus-function claims, generally a court should not import a function of a working device or a preferred embodiment into the claims as part of the "means" if such a function is not part of the function recited in the claims. *See Rodime*, 174 F.3d at 1303.

[33] [34] [35] Next, the court must determine what structure, material, or acts disclosed in the specification correspond to the word "means." *See Chiuminatta Concrete Concepts, Inc. v. Cardinal Indus., Inc.*, 145 F.3d 1303, 1308 (Fed.Cir.1998). In determining the structure disclosed in the specification that corresponds to the means, the court should be wary of importing excess limitations from the specification; corresponding structure does not include structural features that are not needed to actually perform the recited function. *See Wenger Mfg., Inc. v. Coating Machinery Sys., Inc.*, 239 F.3d 1225, 1233 (Fed.Cir.2001); *Asyst Tech., Inc. v. Empak, Inc.*, 268 F.3d 1364, 1370 (Fed.Cir.2001). For example, if a structure is defined in the specification in a way unrelated to the recited function in the means-plus-function clause, those additional aspects of the structure should not be read as limiting the scope of the means clause. *See Chiuminatta*, 145 F.3d at 1308-1309 (construing a patent for an apparatus and method for cutting concrete, court held that because the function that corresponded to the means in the limitation was supporting the surface of the concrete, structural aspects of the skid plate in the preferred embodiment that did not perform this particular function were not to be read as limiting the scope of the means clause). At the same time, whereas in ordinary claim construction, claims may not be limited by functions or elements disclosed in the specification, in claim construction involving a mean-plus-function claim, a party is limited to the structure disclosed in the specification or its equivalents. *See Kahn v. Gen. Motors Corp.*, 135 F.3d 1472, 1476 (Fed.Cir.1998). Thus, the *quid pro quo* of invoking this drafting tool is that the patentee must detail in the specification an adequate disclosure showing what is meant by that language; "[i]f an applicant fails to set forth an adequate disclosure, the applicant has in effect failed to particularly point out and distinctly claim the invention as required by the second paragraph of section 112." *B. Braun Med., Inc. v. Abbott Lab.*, 124 F.3d 1419, 1425 (Fed.Cir.1997) (citation omitted). If a specification includes multiple embodiments, the claim element is to embrace each of those embodiments. *See Micro Chem.*, 194 F.3d at 1258. It must also be remembered that interpretation of what is disclosed must be determined "in light of the knowledge of one skilled in the art." *Atmel Corp. v. Information Storage Devices, Inc.*, 198 F.3d 1374, 1380 (Fed.Cir.1999).

[36] Where s. 112, para. 6 is not invoked, the claim element is not limited to the structure corresponding to the claimed function as " 'described in the specification and equivalents thereof.' " *Envirco Corp. v. Clestra Cleanroom, Inc.*, 209 F.3d 1360 (Fed.Cir.2000) (quoting 35 U.S.C. s. 112, para. 6). Instead, the standard claim construction rules govern. *See id.*

## II. CONSTRUCTION OF THE CLAIMS



The twenty patent claims here presented to the Court for construction may be categorized into the following key groups: (1) Guide Means, Guide Assembly or Guide Element Claims, including Claims 1(b) and 48(c) of the '456 patent, Claim 30(b) of the '009 patent, Claims 3(b), 9(b), 10(b), 14(b), and 15(b) of the '649 patent, and Claim 14 of the '553 patent; (2) Drive Means or Drive Assembly Claims, including Claims 1(d) and 48(d) of the '456 patent, Claims 30(d), 54(b), and 67(b) of the '009 patent and Claims 9(d), 10(e), and 15(d) of the '649 patent; (3) Coupling Member Claims, including Claim 1(e) of the '456 patent; (4) Reserve Vacuum Assembly Claims, including Claim 14 of the '553 patent; (5) Nose Segment Claims including Claim 3(d) of the '649 patent. The parties also request construction of the Preambles of the '009 patent claims, including Claims 34, 53, 54, 55 and 67. These key groups as recited in the above mentioned claims were specifically addressed at oral argument. The parties provided minimal briefing on over twenty-five additional terms, many of which, for reasons which follow, will not be construed by this Court. I begin with those key terms on which the parties chose to present oral argument.

### ***A. Guide Means, Guide Assembly and Guide Element***

Defendants argue that the terms "guide means" "guide assembly" and "guide element" are subject to a means-plus-function analysis under s. 112, para. 6. Plaintiff disputes the application of such an analysis. As highlighted by the joint submission at oral argument, the disputed claim limitations in which "guide means" appear read: FN3 "said positioning ring including guide means formed on an upper surface thereof in a generally arcuate path," (Claim 1(b) of the '456 patent), "said retaining and positioning means including guide means formed thereon which are structured and disposed to guide said cutting head assembly along a generally arcuate path during movement of said cutting head assembly over said retaining and positioning means," (Claim 48(c) of the '456 patent), and "said positioning ring including guide means formed thereon in a generally arcuate path." (Claim 30(b) of the '009 patent).

FN3. The phrase also appears in Claims 2, 3, 6, 8, 12, 29, 46, 47, and 50-52 of the '456 patent, and Claim 14 of the '009 patent.

As highlighted by the joint submission at oral argument, the disputed claim limitations in which "guide assembly" appears read: FN4 "said positioning ring including a guide assembly defining a generally arcuate path," (Claims 3(b), 9(b), 10(b), and 15(b) of the '649 patent), and "said positioning ring including a guide assembly defining a generally arcuate path, said guide assembly including a channel member and a post member." (Claim 14(b) of the '649 patent). The disputed claim limitation in which "guide element" appears reads: "a positioning ring including a cavity adapted to receive a cornea, an aperture for exposing a portion of the cornea of the eye, and a guide element; ... said guide element guiding said head across said aperture making the lamellar incision in the cornea." (Claim 14 of the '553 patent).

FN4. The phrase also appears in Claim 43 of the '009 patent, and Claims 1, and 11-13 of the '649 patent.

Defendants propose that the guiding function in all three terms should be construed as: "directing and facilitating the movement of the cutting head assembly in an arcuate path." (Court Reference Sheet at 1.) They propose that the corresponding function should be comprised of: "a channel, including a toothed track formed thereon, extending in an arcuate path on the upper surface of the positioning ring, and a rigid upstanding member generally opposite the toothed track." ( *Id.*) Plaintiff proposes that: "The term 'guide means' and 'guide assembly' as used in the asserted claims mean a structure on or operably connected to a positioning ring that defines the arcuate path of the microkeratome cutting head during movement across the positioning ring. The 'guide element' of the '553 patent is not limited to an arcuate path but otherwise has the same definition." ( *Id.* at 2.)

[37] I begin with examining the term "guide means." Defendants start with the premise that because the word "means" is included in the term, there is a presumption that s. 112, para. 6 is invoked. Defendants argue that guide means is the same as "means for guiding" and as such is a means-plus-function clause. Defendants stress that plaintiff's proposed construction consists of only the most generic identification of structure and not the mandatory definite structure. They contend that plaintiff's definition would not only encompass any structure, or a limitless range of structures, but is defined purely by what it does: directing a path. Defendants turn to *Valmont Industries, Inc. v. Reinke Manufacturing Company, Inc.*, 983 F.2d 1039, 1042 (Fed.Cir.1993), and argue that plaintiff's proposed construction would allow the claim limitation to encompass all conceivable means for performing the function, which as discussed by the court in *Valmont*, is the harm that Congress sought to avoid when enacting s. 112, para. 6.

Plaintiff acknowledges that the term includes the word "means" and therefore there is a presumption that s. 112, para. 6 is invoked; however, it contends that the presumption is rebutted because sufficient structure is recited to perform the function, and there is no function linked to the word means. Plaintiff compares "guide means" to the "detent mechanism" which was in dispute in *Greenberg v. Ethicon Endo-Surgery, Inc.*, 91 F.3d 1580 (Fed.Cir.1996) and the "second baffle means" term at issue in *Envirco Corporation v. Clestra Cleanroom, Inc.*, 209 F.3d 1360 (Fed.Cir.2000). In *Greenberg*, the Court determined that "the fact that a particular mechanism-here 'detent mechanism'-is defined in functional terms" is not sufficient to bring the claim within the ambit of s. 112, para. 6. *Greenberg*, 91 F.3d at 1583. The Court acknowledged that many devices are named for the function they perform, e.g., "filter," "brake," "clamp," "screwdriver," or "lock." *See id.* The Court, relying purely on dictionary definitions, concluded that detent fell into this category of terms and noted the following:

It is true that the term "detent" does not call to mind a single well-defined structure, but the same could be said of other commonplace structural terms such as "clamp" or "container." What is important is not simply that a "detent" or "detent mechanism" is defined in terms of what it does, but that the term, as the name for structure, has a reasonably well understood meaning in the art.

*Id.* (recognizing the following technical and non-technical dictionary definitions: "a mechanism that temporarily keeps one part in a certain position relative to that of another, and can be released by applying force to one of the parts"; "a part of a mechanism (as a catch, pawl, dog, or click) that locks or unlocks a movement"; "[a] catch or checking device, the removal of which allows machinery to work such as the detent which regulates the striking of a clock") (citations omitted). The Court held that "detent mechanism" was not subject to a mean-plus-function analysis. *See id.* at 1584. In *Envirco*, the court began with the presumption that "second baffle means" was governed by s. 112, para. 6. The court noted that "baffle" is defined in the dictionary as " 'a device (as a plate, wall or screen) to deflect, check, or regulate flow.' " *Envirco*, 209 F.3d at 1365. The court concluded that this definition conveyed a structure that rebutted the presumption that the means-plus-function analysis was invoked. *See id.* Defendants distinguish a baffle from a guide on the ground that a baffle is defined by a definitive range of structures, namely, a plate, wall or screen.

Plaintiff provides the following dictionary definitions for "guide:" "a device by which another object is led in its proper course," *Dorland's Illustrated Medical Dictionary* (25th ed. 1974), "a contrivance for directing motion of something; *esp.*: such a contrivance (as in a tool) having a directing edge, surface, or channel;" and a "grooved director for a surgical probe or knife," *Webster's Third New International Dictionary* at 1009 (1993), "a device for steadying or directing the motion of something," *Webster's Ninth New Collegiate Dictionary* at 541 (1987), and "a device that acts to regulate or direct a motion or operation," *The American Heritage Dictionary* at 581 (2d College ed. 1985). Plaintiff contends that these definitions support its view that the term "guide means" connotes sufficient structure. Plaintiff further argues that the guide means include the further structural limit of a guide in an arcuate path. Defendants counter that the direction the guide moves cannot be considered a "structure."

Defendants counter that plaintiff's own experts support defendants' conclusion that plaintiff's proposed definition encompasses only a generic structure. Dr. Akin provides in his report that: "Despite the appearance of the word 'means,' the term 'guide means' as used in the '456 and '009 patents would be considered *structure* to a person of ordinary skill in the art. The structure being *a device by [sic] which directs an object in its proper path.*" (J.E. Akin, Ph.D., PE, Markman Report at 17 (September 26, 2001), Defs.' Ex. I ("Akin Report")) (emphasis added). Defendants characterize this statement as a functional description of the structure in that the generic structural term "device" is followed by the function of directing an object in its proper path. Dr. Slade provides in his report that: "The term 'guide' was a well recognized structural term to persons of ordinary skill in the art and was widely used to refer to the range of structures that provide for retention and direction of a cutting head assembly as it moves across the opening in the positioning ring." (Rebuttal Report of Stephen G. Slade, M.D. at 5, Defs.' Ex. J ("Slade Report")). Defendants contend that Dr. Slade describes guide means in terms of what it does and offers a limitless structure instead of providing "sufficiently definite" structure.

As noted by plaintiff the Court of Appeals for the Federal Circuit has specifically rejected the argument that a term *must* fall within s. 112, para. 6 if it is defined in functional terms. *See Personalized Media*, 161 F.3d at 705 ("neither the fact that a 'detector' is defined in terms of its function, nor the fact that the term 'detector' does not connote a precise physical structure in the minds of those of skill in the art detracts from the definiteness of structure") (citing *Greenberg*, 91 F.3d at 1583). At the same time, the Court of Appeals has also determined that a device that is described in terms of what it does and not in terms of its structure can at times include any conceivable device, and in those circumstances s. 112, para. 6 must apply. *See Mas-Hamilton Group v. LaGard, Inc.*, 156 F.3d 1206, 1214 (Fed.Cir.1998) ("the claimed 'lever moving element' is described in terms of its function not its mechanical structure. If we accepted [the] argument that we should not apply section 112, para. 6, a 'moving element' could be any device that can cause the lever to move. [The] claim, however, cannot be construed so broadly to cover every conceivable way or means to perform the function of moving a lever, and there is no structure recited in the limitation that would save it from application of section 112, para. 6.").

The term guide means as used in the identified claims recite the function of guiding. *See Georgia-Pacific Corp. v. U.S. Gypsum Co.*, 195 F.3d 1322, 1331 (Fed.Cir.1999) ("a claim term cannot be given a different meaning in the various claims of the same patent.") (citing *Southwall Tech., Inc. v. Cardinal IG Co.*, 54 F.3d 1570, 1579 (Fed.Cir.1995)). Specifically, each identified claim (or subsection thereof) indicates by the language itself that the function served by the "guide means" is to guide the cutting head assembly. Three of the four dictionaries offered essentially define the term "guide" as some object that *directs* the motion of something.FN5 Plaintiff proposes that the term be defined as "a structure ... that *defines* the arcuate path of the ... cutting head...." While use of the word "define" in this context is quite creative, it is clear that plaintiff is really admitting that the guide means performs the function of *directing* that arcuate path. I therefore conclude that plaintiff's argument that the presumption is overcome because no function is recited in the specified claims fails.

FN5. The fourth definition uses the language of leading an object as opposed to directing an object.

The inquiry, of course, does not end there, since plaintiff can still avoid application of s. 112, para. 6 as long as the term includes sufficient structure. As plaintiff relies heavily on dictionaries, I begin by analyzing those definitions. In so doing, I conclude that not a single definition includes any definitive structure. For instance, the Court in *Envirco* was presented with a definition of "second baffle means" which provided the structure of a "plate, wall or screen." *Envirco*, 209 F.3d at 1365. Likewise, the Court in *Greenberg* was offered a definition of "detent mechanism" which provided examples in the shape of a "catch, pawl, dog, or click." *Greenberg*, 91 F.3d at 1583. The definitions advanced here offer the generic shapes of a

"contrivance," a "tool" with a "directed edge, surface or channel," a "grooved director," or simply a "device." Such examples fail to conjure a non-generic form. The definitions offered by plaintiff's experts fail to indicate otherwise. Plaintiff's own construction fails to include sufficient structure. Rather, plaintiff suggests that the term should be defined as "a structure" that accomplishes defining (which as previously discussed is the equivalent of directing) a particular path. Plaintiff's insistence that defining an arcuate path provides structure is not convincing to this Court. As suggested by defendants, the direction in which a device moves does not provide structure. Rather, the indicated path is more properly a function of such device. I therefore conclude that the term does not connote sufficient structure to escape the application of a means-plus-function analysis.

Before continuing with an analysis of the function and corresponding structure of "guide means," I will address whether the means-plus-function analysis shall apply for the terms "guide assembly" and "guide element." I start by highlighting that plaintiff makes no distinction between the term "guide means" and "guide assembly" in its proposed construction. The claim language and context for these two terms are nearly identical. Essentially, the patentee replaced the term "guide means" with the term "guide assembly" in the '649 patent which was filed after this lawsuit was initiated. The only real difference is that certain claims in the latter patent include the addition of the structure of a channel member and a post member. It is true that because the word "means" is not used in the claims, there is a presumption that s. 112, para. 6 does not apply. That presumption is, however, rebuttable. I have already concluded that the use of the term "defining the arcuate path" as used in plaintiff's proposed construction while innovative, is akin to "directing an arcuate path." The same logic applies to the claim language in the '649 patent. While I cannot dispute that this language offers structure not included in the other claims, it is equally significant that this claim was written after this lawsuit was filed, and plaintiff was well aware of the drafting weaknesses of the earlier and related patents. The fact that additional structure was added to the term and the word "means" was replaced with the word "assembly" does not dissuade me from concluding that the term "guide assembly" is subject to a means-plus-function analysis for the same reasons that the term "guide means" is subject to that analysis.

As to the term "guide element," again, while the term "means" is not used, and therefore a presumption exists that a means-plus-function analysis does not apply, the term clearly denotes a function of guiding the head. Moreover, no structure is offered in the claim. For these reasons, and for the same reasons that the terms "guide means" and "guide assembly" are subject to s. 112, para. 6, I conclude that the term "guide element" is also subject to s. 112, para. 6.

Having so concluded, I must now determine the functions linked to those related terms. Defendants propose the following function for each term: "directing and facilitating the movement of the cutting head assembly in an arcuate path." The only flaw I find in this proposal is the word "facilitating." The Court of Appeals for the Federal Circuit has been clear that the function must come from the claim language itself. *See* Generation II, 263 F.3d at 1363; *Micro Chem.*, 194 F.3d at 1258. Defendants, it appears, have imported the word "facilitating" from the following language in the written description of the '456 patent: "In any event however, the guide means 40 will be disposed on the positioning ring 32 so as to guide and facilitate movement of the cutting head assembly 50...." Col. 7, lns. 32-34. I conclude that the plain language of the actual claims provide for the function of directing the movement of the cutting head assembly in an arcuate path. *See, e.g.* Claim 48(c) of the '456 patent. The function for the term "guide element" varies in that its function is not to guide the cutting head in an arcuate path, but to guide the head across the aperture making a lamellar incision. *See* Claim 14 of the '553 patent. Thus, the guide element does not have a function of guiding in an arcuate path.

[38] The next step is to determine the corresponding structures. As previously provided, defendants propose the following structure: "a channel, including a toothed track formed thereon, extending in an arcuate path on the upper surface of the positioning ring, and a rigid upstanding member generally opposite the toothed

track." (Court Reference Sheet at 1.) In the event that this Court employs a means-plus-function analysis, plaintiff proposes the following structure: "a channel member, with or without a toothed track, or a rigid upstanding member such as a post, or both, or other equivalent structures." (Pl's Reply Br. at 15.) Thus, the two key questions are whether the structure includes a toothed track and whether the structure includes a rigid upstanding member. Plaintiff argues that the toothed track is part of the most preferred embodiment and the rigid upstanding member is part of the preferred embodiment; accordingly, under *Micro Chem.*, 194 F.3d at 1258-59, neither structure should be included in the corresponding structure. Plaintiff takes the position that the function is accomplished by *either* the channel member (which need not have a toothed track) *or* the rigid upstanding member. The Court of Appeals in *Micro Chem.* noted that in determining the structure linked to the identified function, no structure should be incorporated from the written description beyond what is necessary to perform the function as stated in the claim. *See id.* The Court did not hold that structure which is part of a preferred embodiment can never be part of the "corresponding structure" of a means-plus-function claim. Defendants direct the Court to *Kahn*, 135 F.3d at 1476, in which the Court of Appeals noted that the corresponding structure includes that which is clearly linked or associated in the specification. In *B. Braun Medical v. Abbott Lab.*, 124 F.3d 1419, 1425 (Fed.Cir.1997), the Court explained that once s. 112, para. 6 is invoked, the patentee must detail in the specification an adequate disclosure showing what is meant by that language; "[i]f an applicant fails to set forth an adequate disclosure, the applicant has in effect failed to particularly point out and distinctly claim the invention as required by the second paragraph of section 112." Accordingly, this Court concludes that if the *only* structure identified in the specification to perform the determined function is part of the preferred embodiment, such structure must be part of the "corresponding structure," or else the patentee has failed to claim any structure. *See Mitek Surgical Prod., Inc. v. Arthrex, Inc.*, 230 F.3d 1383, 2000 WL 217637, at \*2-3 (Fed.Cir.2000) (per curiam) (unpublished) (affirming decision of district court that limited claim to preferred embodiment because it was the only embodiment; determining that disclosures in prior art were irrelevant because structure in prior art may only be used to limit and not broaden the scope of means-plus-function structures).

As stated above, plaintiff takes the position that the function of the guide means is accomplished by either the rigid upstanding member or the channel member (which may or may not include a toothed track); both structures, according to plaintiff, are not needed. I begin with the possible inclusion of a rigid upstanding member and note that the "guide assembly" as defined in Claim 14(b) of the '649 patent specifically includes a "post member." FN6 The specification of the '456 patent reads:

FN6. In determining whether the corresponding structure includes a rigid upstanding member, this Court found Figures 5A, 5B and 5C of the '456 patent useful. (App. at i.)

The guide means 40 further comprise a rigid upstanding member 44 disposed on the retaining and positioning means 30, and generally opposite the toothed track 43.... From the explanation which follows, it will become clear that channel member 42 and rigid upstanding member 44 permit the cutting head assembly 50 of this invention to become effectively guided.... It will also be appreciated that in assembled form, upstanding member 44 acts as additional guide means for enabling the cutting head assembly 50 to be driven along an arcuate path.

Col. 8, lns. 11-13, 18-22; Col 9, lns. 40-44. These highlighted passages do not even describe a preferred embodiment of the rigid upstanding member. Rather, the specification indicates that the rigid upstanding member is a necessary element of guiding the cutting head and is positioned generally opposite the toothed track. Plaintiff's argument that the rigid upstanding member is merely additional guide means and therefore not necessary to perform the function is unavailing. As pointed out by defendants, the word "additional" does not mean "alternative." I therefore conclude that the rigid upstanding member is part of the corresponding structure.

The following language from the specification of the '456 patent directs this Court's determination of whether the toothed track is part of the corresponding structure.FN7

FN7. In determining whether the corresponding structure includes a toothed track, this Court found Figures 5A, 5B, 5C, 7 and 11 of the '456 patent useful. (App. at i, ii and v.)

Referring to FIGS. 5-A and 5-C, in the preferred embodiment, guide means 40 are seen to comprise a *channel member 41, 42* .... As depicted in FIG. 5-A, *channel member 41* may comprise an elongated "C" shaped structure or even an inverted "L" shaped structure.... As illustrated in FIGS. 5-B and 5-C however, in the most preferred embodiment *channel member 42* is formed by interconnection of two separate elements, namely, an upwardly and arcuately extending sidewall 36 formed on positioning ring 32, and a *toothed track 43* which is interconnected with sidewall 36.... Thus, guide means 40 in the form of a generally "C" shaped channel member 42 is comprised by the combined structure of sidewall 36 and *toothed track 43*.... With respect to the embodiment shown in FIG. 5-A, it is contemplated that a *toothed track* may also be mounted to an upper surface of positioning ring 32 or to an upper surface of *channel member 41*. It will be appreciated that *toothed track 43* cooperated with drive means 80 (see FIGS. 7 and 11) so as to drive the cutting head assembly 50 across positioning ring 32.

Col. 7, lns. 36-38, 42-45, 47-52; Col. 8, lns. 1-10 (emphasis added).

Thus, the specification does appear to disclose a channel member without a toothed track as depicted in Figure 5A. The problem, however, is that the specification does not in any way explain how that embodiment could actually direct the cutting head assembly. The specification only details how a channel member with a toothed track can perform the guide means function. The patentee describes only a toothed track which mates with the propulsion shaft 125 to guide the cutting head assembly in an arcuate path. The teeth of the channel (with the power transmitted thereto) are the core of the guiding process. Without it, there is no structure that can effectively guide the cutting head assembly. This Court is well aware of the mandate not to import excess limitations from the specification. *See, e.g., Wenger Mfg., Inc. v. Coating Machinery Sys., Inc.*, 239 F.3d 1225, 1233 (Fed.Cir.2001). I am equally mindful, however, that in construing a means-plus-function claim, the inventor is limited to the structure disclosed in the patent, *see Kahn v. Gen. Motors Corp.*, 135 F.3d 1472, 1476 (Fed.Cir.1998), and must sufficiently disclose such structure or the invention fails to comport with s. 112, para. 2, *see B. Braun Med., Inc. v. Abbott Lab.*, 124 F.3d 1419, 1425 (Fed.Cir.1997).

[39] [40] Plaintiff also attempts to invoke the doctrine of claim differentiation to support its position that the toothed track is not part of the corresponding structure. Under this judicially created doctrine, it is presumed that each claim in the patent is different in scope. *See Intermatic Inc. v. Lamson & Sessions Co.*, 273 F.3d 1355, 1364 (Fed.Cir.2001); *Wenger*, 239 F.3d at 1233. At the same time, "claim differentiation is not a 'hard and fast rule of construction,' and cannot be relied upon to 'broaden claims beyond their correct scope.'" *Wenger*, 239 F.3d at 1233 (quoting *Kraft Foods, Inc. v. Int'l Trading Co.*, 203 F.3d 1362, 1368 (Fed.Cir.2000)). *See also Laitram Corp. v. Rexnord, Inc.*, 939 F.2d 1533, 1538 (Fed.Cir.1991) (rejecting argument that "means for joining" limitation could not include a "cross member" because that limitation was recited in a dependent claim; "[a] means-plus-function limitation is not made open-ended by the presence of another claim specifically claiming the disclosed structure which underlies the means clause or an equivalent of that structure.") (alteration in original). Thus, the stringencies of a means-plus-function limitation cannot be escaped merely by adding a dependent claim that recites the corresponding structure disclosed in the specification. *See Wenger*, 239 F.3d at 1234. Plaintiff contends that because the toothed track is claimed in dependent Claims 44 and 45 of the '456 patent, the toothed track may not be imported into the corresponding structure of the independent claims. I conclude that this argument runs counter to the case law from the Court of Appeals for the Federal Circuit which clearly indicates that a dependent claim cannot be relied upon to avoid the strictness of a means-plus-function limitation.

I therefore conclude that the corresponding structure is also comprised of a channel member with a toothed track mounted or formed thereon. Defendants propose that the construction further require that the channel

extend in an arcuate path on the upper surface of the positioning ring. The specification of the '456 patent provides: "guide means 40 are seen to comprise a *channel member 41, 42*, which extends along a length of at least one side of positioning ring 32 and preferably, on an upper surface of positioning ring 32." Col. 7, lns. 37-40. Thus, the description requires only that the channel member extend along at least one side of positioning ring; it need not be on the upper surface thereof. The specification further provides: "It will also be appreciated ... that channel member 41, 42 extends across ring 32 in an arcuate or semi-circular path." Col. 7, lns. 40-42.

Lastly, I turn to the corresponding structure for guide element. While the claim language of the term "guide element" indicates a varied function from that of guide means and guide assembly, the specification does not mention this means-plus-function claim term. I must therefore conclude that plaintiff has failed to set forth an adequate disclosure, and has, in effect failed to particularly point out and distinctly claim the invention as required by the second paragraph of section 112. *See* B. Braun Medical, 124 F.3d at 1425.

In summary, this Court has made the following conclusions with respect to the guide terms. Each term, guide means, guide assembly and guide element, are subject to s. 112, para. 6. The functions for guide means and guide assembly are the same: directing the movement of the cutting head assembly in an arcuate path. The corresponding structure includes a channel member with a toothed track that is formed or mounted thereon and extends in an arcuate or semi-circular path along at least one side of positioning ring and a rigid upstanding member, such as a post, that is positioned generally opposite the toothed track. As depicted in Figures 5A, 5B and 5C the guide means includes both a channel member and a rigid upstanding member; these embodiments clearly demonstrate that both structural elements perform the function of directing the cutting head assembly. This Court therefore rejects plaintiff's argument that either element can alone perform the function of directing the movement of the cutting head assembly in an arcuate path. As to the term guide element, because the inventor did not disclose any corresponding structure in the specification, the patentee failed to claim this portion of the invention.

### ***B. Drive Means and Drive Assembly***

[41] The parties agree that the term "drive means" is subject to a means-plus-function analysis. As highlighted in the joint submission of the parties at oral argument, the disputed claim limitations in which "drive means" appear read: FN8 "drive means operably connected to said cutting head assembly *for causing movement* of said cutting head assembly across said positioning ring and *for causing oscillating movement* of said cutting element," (Claim 1(d) of the '456 patent) (emphasis added), "drive means operably connected to said cutting head assembly *for causing automated movement* of said cutting head assembly over said retaining and positioning means along said arcuate path," (Claim 48(d) of the '456 patent) (emphasis added), "drive means operably coupled to said cutting head assembly *for causing movement* of said cutting head assembly across said positioning and *for causing oscillating movement* of said cutting element," (Claim 30(d) of the '009 patent) (emphasis added), "surgical device including ... drive means operably connected to said cutting head assembly *for causing movement* of said cutting head assembly across the positioning ring and *for causing oscillating movement* of the cutting blade assembly," (Preamble of Claim 34 of the '009 patent) (emphasis added).

FN8. The phrase also appears in Claim 18, 28, and 46 of the '456 patent, Claims 1, 3-6, 8, and 9 of the '553 patent, and Claims 1, 9, 14, 23, 32, 35, 47, 50, 51, 64, and 65 of the '009 patent.

The parties also appear to agree that the function should be construed as causing both movement of the cutting head assembly across the positioning ring and causing oscillating movement of the cutting element, or merely causing movement of the cutting head assembly, depending on what claim is involved. (Tr. at 77-78.) In other words, in Claims 1(d) of the '456 patent, 30(d) of the '009 patent and preamble 34 of the '009

patent, the function is to cause both the movement and the oscillating movement, whereas in Claim 48(d) of the '456 patent, the function is to cause only movement. The parties do not highlight for this Court any claim in which the only stated function is to cause the oscillating movement.

Having determined these functions, I will turn to analyzing the corresponding structure. Defendants contend that regardless of whether the function is to cause movement or cause oscillating movement, the structure is the same and includes: the gear box 81, the motor main drive shaft 101, the threaded drive screw ("worm") 115, the oscillating shaft 130, the oscillating pin 135, the worm gear 120, and the propulsion shaft 125. (Court Reference Sheet at 1.) Plaintiff contends that when the function calls for causing movement, the structure includes: the motor 100, FN9 the gearbox 81, and the worm 115, and that when the function calls for causing oscillating movement, the structure includes the motor 100, the gearbox 81, and the oscillation shaft 130. ( *Id.*) Thus, the two key issues are (1) whether the structure is separable as plaintiff contends, and (2) whether the structure includes the worm gear 120 and the propulsion shaft 125.

FN9. The Court Reference Sheet indicates that plaintiff proposes that the motor 80 should be included in the corresponding structure. In the specification, however, the number 80 is attached to the drive means, not the motor, while the number 100 is attached to the motor. This Court will therefore assume that a typo is to blame for the confusion. This interpretation is supported by the briefing of plaintiff.

Defendants argue that whether the function is to move the cutting head or to oscillate the blade, the structure is the same because a single integrated drive accomplishes both functions. In order to move the cutting head, the blade must oscillate and vice versa. Plaintiff counters that the integration only exists in the preferred embodiment; however, plaintiff fails to point to another embodying structure included in the specification. In *Rodime PLC v. Seagate Technology, Inc.*, 174 F.3d 1294, 1304 (Fed.Cir.1999), the court held that the district court had erred in interpreting the claims at issue to require the function of thermal compensation. In so holding, the court observed that the term "positioning means" did not employ that function in three of the claims, but did include that function in a separate claim not at issue in the litigation. *See id.* at 1304-05. The court noted the following:

In other words, the narrower claim 11 adds a thermal compensation function expressly not included in the broader claims 3, 5, and 8. Had [the patentee] intended or desired to claim thermal compensation as a function of the positioning means in the asserted claims, it could have done it explicitly, as in claim 11. *The absence of any such explicit language, however, shows that claims 3, 5, and 8 do not include the function of thermal compensation.*

*Id.* at 1305 (emphasis added). This language suggests that the functions are separable. However, the court added that:

[The specification] merely highlights the unremarkable fact that a particular means may perform more than one function. It does not follow, however, that the positioning means in claims 3, 5, and 8 necessarily performs both these functions.... *Indeed, the two functions are not inextricably intertwined. Rather, the specification associates separate structure with each separate function ....* In other words, thermal compensation is an additional function, with separate, additional structure, included within this patent as a separate claimed feature within the broader parameters of the entire claimed invention. Each claim, however, need not carry the limitations of narrower, specific claimed features. The specification makes this distinction and supports the interpretation of this language of claims 3, 5, and 8 which recite only the function of movement between tracks.

*Id.* (emphasis added). In the claims before this Court, the functions of moving the cutting head assembly and oscillating the blade are inextricably intertwined because one function cannot occur without the other



function occurring. *Cf.* Interactive Pictures Corp. v. Infinite Pictures, Inc., 274 F.3d 1371, 1383 (Fed.Cir.2001) (where two function are closely related and are accomplished by same structure, the two associated functions are considered one limitation under the equivalency analysis); Georgia-Pacific Corp. v. U.S. Gypsum Co., 195 F.3d 1322, 1331 (Fed.Cir.1999) ("a claim term cannot be given a different meaning in the various claims of the same patent.") (citing Southwall Tech., Inc. v. Cardinal IG Co., 54 F.3d 1570, 1579 (Fed.Cir.1995)). As the cutting head assembly is moved, the blade oscillates at the same precise time. The specification does not include an embodiment where these two functions do not occur simultaneously, and I cannot envision such an event from the permissible language of the patent. I thus conclude that the drive means performs two functions and because these functions cannot occur independently, the corresponding structure is the same.

I now turn to whether the drive means structure includes the worm gear 120 and the propulsion shaft 125. FN10 Defendants argue that the specification clearly links these two elements to the stated functions. Plaintiff contends that these two elements are part of the cutting head assembly which is connected to, but not part of, the drives means. In support, plaintiff turns to the prior art and argues that those skilled in the art would understand that the worm gear and propulsion shaft are part of the cutting head assembly and not the drive means. Plaintiff also directs this Court to *Asyst Technologies, Inc. v. Empak, Inc.*, 268 F.3d 1364, 1371 (Fed.Cir.2001), in which the court determined that elements which merely "enable" the means to perform are not part of the corresponding structure; rather, the "means-plus-function limitation must actually perform the recited function." The *Asyst* court offered the following analogy: while an electrical outlet enables a toaster to operate, the outlet is not considered to be part of the toaster. *See id.* Plaintiff contends that the worm gear and propulsion shaft merely enable the drive means, but do not actually perform the function.

FN10. In determining whether the corresponding structure includes these elements this Court found Figures 7, 8 and 11 of the '456 patent useful. (App. at ii-iv.)

The specification of the '456 patent provides:

It is noted that the screw-like threaded surface of the worm 115 enables the worm 115 to rotate without moving vertically and successively engage the drive recesses on the worm gear 120 to effect rotation thereof.... The propulsion shaft 125 ... is structured to ... engage the toothed track 43 on the positioning ring 32 such that *upon rotation of the worm gear 120*, and accordingly rotation of the propulsion shaft 125, *the propulsion shaft 125 rides along the toothed track 43 and drives the cutting head assembly 50 across the positioning ring 32.*

Col 14, lns. 64-67; Col. 15, lns. 3-11 (emphasis added). That portion of the specification which discusses the cutting head assembly does not include any discussion of the worm gear or the propulsion shaft. In fact, these two elements are only discussed in the context of the driving means. One of the problems with plaintiff's argument is that while this Court is directed to interpret the corresponding structure through the eyes of one skilled in the art, *see Atmel Corp. v. Infor. Storage Devices, Inc.*, 198 F.3d 1374, 1380 (Fed.Cir.1999), it is also directed to use prior art only to limit and not expand the scope of means-plus-function structures, *see Mitek Surgical Prod., Inc. v. Arthrex, Inc.*, 230 F.3d 1383, 2000 WL 217637, at \*2-3 (Fed.Cir.2000) (per curiam) (unpublished) (citing *Biodex Corp. v. Loredan Biomedical, Inc.*, 946 F.2d 850, 863 (Fed.Cir.1991)). The specification serves as the basic guide for determining what structure corresponds to the word "means." *See Chiuminatta Concrete Concepts, Inc. v. Cardinal Industries, Inc.*, 145 F.3d 1303, 1308 (Fed.Cir.1998). Thus, the location of the elements is not the key factor; the focus is rather on whether the elements actually perform the means function.

It could not be more transparent from quoted passage of the specification that the propulsion shaft is clearly

linked to the function of driving (or moving) the cutting head assembly across the positioning ring. The written description vividly states that the propulsion shaft performs this function. The worm gear, on the other hand, serves as an enabler. The worm gear is not the source of the power. In other words, it functions to allow the propulsion shaft to rotate which in turn actually performs the driving (or moving) function. Thus, I conclude that under the reasoning of *Asyst*, the worm gear enables the propulsion shaft to perform the means function and is therefore not part of the drive means.

While plaintiff does not highlight the issue, the court must also determine whether the oscillating pin 135 is part of the corresponding structure. FN11 The specification of the '456 patent provides as follows:

FN11. In making this determining, this Court found Figure 11 of the '456 patent useful. (App. at iv.)

The oscillation pin 135 ... is structured to extend into a slot 72' formed in an upper surface of the blade holder 72. As such, *upon axial rotation of the oscillation shaft 130, the oscillation pin 135 rotates a predetermined radius off center and alternately engages opposite side edges of the slot 72' of the blade holder 72 to result in alternating, oscillating movement of the blade holder 72 and the cutting element 70 held thereby.*

Col. 14, lns 28-36 (emphasis added). I conclude that this language indicates that the oscillation pin 135 performs the oscillation function.

Finally, as acknowledged by plaintiff, the corresponding structure includes the motor 100: "The driving means preferably include a motor 100." '456 patent, Col. 13, lns. 25-26. Defendants argues that the structure should also include the motor main drive shaft 101, to which plaintiff offers no reply. I will therefore include the motor main drive shaft 101 as part of the corresponding structure.

I now construe the term "drive assembly." As highlighted in the joint submission of the parties at oral argument, the term "drive assembly" appears only on the latter two issued Hellenkamp patents, namely the '009 patent and the '649 patent. As used in the these patents, the claim language nearly mirrors the claim language of the '456 patent, which employs the term "drive means" instead of "drive assembly." FN12 Plaintiff contends that the term drive assembly does not fall within the ambit of s. 112, para. 6. Plaintiff's primary argument is that the preambles to Claims 54 and 67 of the '009 patent include no function. This position ignores the following important points. First, Claims 9(d), 10(e) and 15(d) of the '649 patent clearly include the identical functions of the guide means: causing movement of the cutting head assembly and causing oscillating movement of the cutting element. Second, Claims 54(b) and 67(b) of the '009 patent incorporate a function of driving the blade holder. Third, while the preambles to Claims 54 and 67 of the '009 patent may include no recited function, it is also true that the heart of those claims concern what comprises the cutting head assembly.

FN12. Specifically, the term is recited in the following claims: "A cutting blade assembly to be used with a surgical device that cuts at least partially across a cornea of an eye of a patient, the surgical device including a drive assembly, said cutting blade assembly comprising," (Preambles of Claims 54 and 67 of the '009 patent); "a blade holder, said blade holder secured to said cutting blade and structured to be operably driven by the drive assembly of the surgical device," (Claim 54(b) of the '009 patent), "a blade holder having an underside, said underside of said blade holder secured to said cutting blade at said at least one aperture formed in said cutting blade, and said blade holder structured to be operably driven by the drive assembly of the surgical device from a generally vertical plane," (Claim 67(b) of the '009 patent), "a drive assembly operably connected to said cutting head assembly from generally vertical orientation for causing movement of said cutting head assembly across said positioning ring and for causing oscillating movement of said cutting element," (Claim 9(d) of the '649 patent), "a drive assembly operably connected to said cutting head assembly from generally a vertical orientation for causing movement of said cutting head assembly across said positioning ring," (Claim 10(e) of the '649 patent), and "a drive assembly operably connected to said

cutting head assembly from a generally vertical orientation for causing oscillating movement of said cutting element," (Claim 15(d) of the '649 patent). The term also appears in Claims 13 and 15-20 of the '553 patent, in Claims 43, 56, 63 and 66 of the '009 patent, and in Claims 8, 11, and 12 of the '649 patent.

Most critical, however, is plaintiff's proposed construction: "The term 'drive assembly' is a structure that connects to the cutting head assembly and imparts movement to the cutting head assembly, oscillating movement to the cutting element, or both (depending on the claim-'649 patent claim 9 recites both cutting head movement and oscillation, claim 10 recites cutting head movement, and claim 15 recites oscillation)." (Court Reference Sheet at 2.) This construction is the equivalent of the function of the drive means: causing movement of the cutting head assembly across the positioning ring and oscillating movement of the cutting element. The addition of the word structure is only a bare word which fails to include a description for such structure. I therefore conclude that s. 112, para. 6 applies to the term "drive assembly," and the construction of the term drive assembly is identical to that of the term drive means.

In summary, this Court has made the following conclusions with respect to the drive terms. Both terms, drive means and drive assembly, are subject to s. 112, para. 6. The drive terms have the same two functions: causing both movement of the cutting head assembly across the positioning ring and oscillating movement of the cutting element. The corresponding structure of these functions for both terms are not separable and include a motor 80, a gearbox 81, a motor main drive shaft 101, a threaded drive screw (or worm) 115, an oscillation shaft 130, an oscillation pin 135, and the propulsion shaft 125. The corresponding structure does not include the worm gear 120.

### ***C. Coupling Member***

[42] As highlighted in the joint submission of the parties at oral argument, the recitation of "coupling member" appears in the Claim 1(e) of the '456 patent: FN13 "a coupling member structured and disposed to detachably couple said cutting head assembly and said positioning ring and including means for permitting movement of said cutting head assembly relative to said positioning ring along said generally arcuate path."

FN13. The term also appears in Claims 12, 13 and 46 of the '456 patent.

Again, the primary dispute between the parties with respect to this term is that defendants argue that s. 112, para. 6 is invoked, while plaintiff contends it is not. Defendants propose the following construction: the function should be construed as a "separate element for coupling the cutting head assembly to the positioning ring," and the corresponding structure should be comprised of: a retaining segment 92, including an aperture 94 formed therein; and a pivot segment 95 structured and disposed to be coupled to the rigid upstanding member 44 of the positioning ring 32 and to permit coupling member 90 and accordingly, the cutting head assembly 50 connected thereto, to pivotally move about post member 45. (Court Reference Sheet at 1.) Plaintiff counters with the following construction: "the term 'coupling member' is a structure that detachably joins the cutting head assembly and the positioning ring." ( *Id.* at 2.)

As with the guide terms, the defendants essentially argue that "coupling member" connotes only the most generic structure and is therefore subject to a means-plus-function analysis. Plaintiff counters that the term invokes sufficiently definitive structure to those skilled in the art to escape s. 112, para. 6. The dictionary definitions provided by plaintiff define coupling as "a pairing or joining," *Dorland's Illustrated Medical Dictionary* (25th ed. 1974), "a device that serves to connect the ends of adjacent parts or objects," *Webster's Ninth New Collegiate Dictionary* at 299 (1987), "[s]omething that links or connects, as a railroad coupler," *The American Heritage Dictionary* at 332 (Second College ed. 1985), and define member as "[a] structural unit such as a wall, column, beam, or tie, or a combination of any of these," *McGraw-Hill Dictionary of*

*Scientific and Technical Terms* (5th ed. 1994). Dr. Akin, an expert for the plaintiff, defines coupling member as "a mechanism or device to join two or more elements." (Pl.'s Ex. 10, Akin Report at 7.) Dr. Slade, plaintiff's rebuttal expert, offers this definition: "a structural element that detachably couples the cutting head and the positioning ring together." (Pl.'s Ex. 11, Slade Report at 6.) Plaintiff's own proposed construction mirrors that of its experts. These definitions essentially rely on the generic shapes of a "device," "structure," "something" and "mechanism" to accomplish the function of joining, linking, or connecting. I therefore conclude that for the same reasoning which led me to conclude that the guide and drive terms invoked s. 112, para. 6, coupling member is also under its ambit. None of these definitions indicate that the term would call to mind for those skilled in the art a range of structures sufficient to escape a means-plus-function analysis. To hold otherwise, would be to include every conceivable device. *See Mas-Hamilton Group v. LaGard, Inc.*, 156 F.3d 1206, 1214 (Fed.Cir.1998).

Having so concluded, I now turn to determining the function of the coupling member. The claim language is clear on this point. The function is to detachably connect or join the cutting head assembly and the positioning ring.

The specification of the '456 patent provides:

*[C]oupling member 90 comprises two segments: a) a retaining segment 92 and b) a pivot segment 95.... The retaining segment 92 also includes an aperture 94 formed therein to correspond to aperture 58 of housing 51. As such, aperture 94 is sized and configured to allow passage of the driving shaft of the driving means 80 ... there through and into aperture 58 of the housing 51. Thus, in assembled form, coupling member 90 is securely yet removably coupled to head assembly 50 as a result of the engagement of the driving means 80 with the housing 51 through retaining segment 92.*

Col. 8, lns. 64-66; Col. 9, lns. 3-11 (emphasis added). Accordingly, the corresponding structure FN14 which provides the means for detachably connecting the cutting head assembly and the positioning ring is retaining segment 92, which includes aperture 94, and pivot segment 95. FN15

FN14. In determining this corresponding structure, this Court found Figure 6 of the '456 patent useful. (App. at i.)

FN15. Defendants bring forth a construction of the coupling member in Claim 53 para. 2 of the '009 patent. Plaintiff, however, never designated that claim as being one that was infringed by defendants' invention. I therefore decline the opportunity to construe this Claim.

In summary, the term coupling member is subject to a means-plus-function analysis. The function is to detachably connect or join the cutting head assembly and the positioning ring. The corresponding structure includes retaining segment 92, which includes aperture 94, and pivot segment 95.

#### ***D. Reserve Vacuum Assembly***

[43] The recitation of "reserve vacuum assembly" appears only in Claim 14 of the '553 patent, which reads: "An instrument for making a lamellar incision in a cornea of an eye comprising: ... a reserve vacuum assembly coupled to said positioning ring to sustain the vacuum within said cavity if operation of said vacuum pump is interrupted as the head moves across the aperture." Defendants contend that a means-plus-function analysis applies, while plaintiff disputes its application.

As the term does not use the word "means," there is a presumption that the means-plus-function analysis

does not apply. Reserve is defined as "something kept in store for future use." *Dorland's Illustrated Medical Dictionary* (25th ed. 1974). Vacuum is defined as "a space partially exhausted (as to the highest degree possible) by artificial means (as an air pump)," *Merriam Webster Medical Dictionary* available at <http://www.intelihealth.com> and *Meriam-Webster's Collegiate Dictionary* available at <http://www.m-w.com>, and "a device creating or utilizing a partial vacuum," *Webster's Third New International Dictionary* at 2527 (1986). Assembly is defined as a "unit containing the component parts of a mechanism, machine, or similar device." *McGraw-Hill Dictionary of Scientific and Technical Terms* at 139 (5th ed. 1994). These ordinary definitions amount to a device, such as a pump, that creates a partially exhausted space to be kept in store for future use.

It is true that Hellenkamp's creation of the reserve vacuum assembly does not call to mind a single well defined structure, and the term as used in Claim 14 of the '553 patent is defined in terms of what it does, namely, sustaining the vacuum if operation of the vacuum pump is interrupted. However, the term is akin to clamp, container, filter, lock, which have been held to be outside the reach of s. 112, para. 6. *See Greenberg v. Ethicon Endo-Surgery, Inc.*, 91 F.3d 1580, 1583 (Fed.Cir.1996). The key here is that while the term does not connote a precise physical structure to those of ordinary skill in the art, it does convey a variety of structures that are referred to by that term. *See Personalized Media Communications, LLC v. Int'l Trade Comm'n*, 161 F.3d 696, 704-05 (Fed.Cir.1998). I therefore conclude that the a means-plus-function analysis does not apply to the construction of the term reserve vacuum assembly.

Defendants argue that if the normal rules of construction are to apply, the term should be construed as "an assembly, including a reserve tank-or store-of vacuum, for storing or holding in reserve a supply of vacuum." (Defs.' Br. at 31.) Plaintiff proposes the following construction: "The structure to one of ordinary skill in the art that is a reliable alternate source of vacuum." (Court Reference Sheet at 2.) Thus, defendants wish to limit the claim to the vacuum tank recited in Claims 2, 12 and 13(g) of the '553 patent, while plaintiff wishes to expand the term to encompass any mechanism which can provide an alternate source of vacuum.

The specification does not mention the term reserve vacuum assembly; rather, it discloses the embodiment of a tank, as claimed in Claims 2, 12 and 13(g), to perform the function of sustaining the vacuum.FN16 Thus, limiting the claim to the tank would amount to importing a limitation into the claim from the specification. Defendants argue that the prosecution history indicates that the tank is the equivalent of the assembly. The applicant's amendment of March 1, 1999 provides: "a control assembly which in addition to detecting an interruption in the operation of the vacuum pump, also includes a reserve vacuum tank to maintain vacuum, thereby obviating the need to interrupt the cutting of the eye." (Defs.' Ex. O at 19.) The amendment, however, also explains the reserve vacuum assembly, providing: "new independent claim 18 is directed to a surgical device having a control assembly which includes the reserve vacuum tank.... New independent claim 19 is directed to an instrument for making a lamellar incision in a cornea of an eye having a reserve vacuum assembly, ... structured to sustain the vacuum.... These claims address the situation wherein operation of the vacuum source or vacuum pump may at least temporarily stop.... In such a situation the Applicant's invention, as recited in claims 18 and 19, provide back-up or reserve vacuum assembly which maintains a sufficient vacuum." ( *Id.* at 18.) Thus the prosecution history includes both the embodiment of a tank and the broader assembly. The word reserve, however, is employed as a limiting word in Claim 14. I therefore conclude that the proper construction is based on the term's ordinary meaning: "the structure, including but not limited to a tank, to one of ordinary skill in the art that is a reserve source of vacuum."

FN16. This embodiment is depicted in Figure 11 of the '553 patent. (App. at vii.)

### ***E. Nose Segment***

[44] The term "nose segment" is recited in Claim 3(d) of the '649 patent which reads: FN17 "said cutting head assembly further including a nose segment structured to appanate the cornea to be cut; said nose segment structured to move in unison at substantially all times with said cutting head assembly in both a forward and a reverse direction over said positioning ring along said generally arcuate path defined by said guide assembly." Defendants support the following construction: "the separable forward part of the cutting head assembly," (Court Reference Sheet at 1), and plaintiff proposes the following: "the forward section on the cutting head that appanates the cornea," ( *id.* at 2). Thus, the key dispute is whether the piece is separable, as proposed by defendants, or integral, as argued by plaintiff.

FN17. It is also recited in Claims 34 and 35 of the '456 patent and Claim 1(d) of the '649 patent.

Defendants argue that the nose segment must be separable or the claim would not specify that it "move[s] in unison at substantially all times with said cutting head assembly." In other words, if the nose segment was fully integrated with the cutting head assembly, there would be no need to point out that it moved in general unison with the cutting head assembly. This is a powerful argument, for if the nose segment is to be integrated, the last part of the claim would be wholly redundant.

Defendants further contends that any ambiguity is resolved by the specification of the '649 patent which reads: "Preferably, the depth adjusting means 75 comprise a *separate* nose segment 76, which is structured to be securely, yet removably interconnected with housing 51 by way of a conventionally known fasteners 74 such as a screw, bolt, etc." Col 10, ln. 60-Col. 11, ln. 3 (emphasis added). Thus, the specification describes a separate piece. While it is clear that the patentee is not mandated to describe in the specification every possible embodiment, *see* *Rexnord Corp. v. Laitram Corp.*, 274 F.3d 1336, 1344 (Fed.Cir.2001), one may turn to the written description to define a term already in a claim limitation because a claim must be read in view of the specification of which it is a part, *Renishaw PLC v. Marposs Societa per Azioni*, 158 F.3d 1243, 1248 (Fed.Cir.1998).

Plaintiff relies on *Rexnord* in which the Court of Appeals held that the term "portion" embraced structure that may be either integral or separate. 274 F.3d at 1345. Plaintiff analogizes "segment" to "portion," which shares a similar dictionary definition. The *Rexnord* court, however, found it significant that the specification described more than one embodiment. *See id.* The inventor had also specifically noted that the invention could be carried out in a number of ways. *See id.* Here, the specification describes only an embodiment of a separate nose segment which is secured to the cutting head assembly and removable therefrom. I therefore adopt defendants' proposed construction for the term nose segment: "the separable forward part of the cutting head assembly."

### ***F. Preambles***

[45] [46] The parties provided briefing on preambles for multiple claims in multiple patents; however, they presented oral argument only on the preambles for certain claims of the '009 patent. This Court will therefore only construe the reach of the preambles which were discussed at oral argument. A preamble is not deemed limiting if it "merely states a purpose or intended use of the invention." *In re Paulsen*, 30 F.3d 1475, 1479 (Fed.Cir.1994). *See also* *Bristol-Myers Squibb Co. v. Ben Venue Lab. Inc.*, 246 F.3d 1368, 1375-76 (Fed.Cir.2001) (preamble reading a "method for treating a cancer patient to effect regression of a taxol-sensitive tumor, said method being associated with reduced hematologic toxicity" held to be a statement of purpose that failed to result in a "manipulative difference in the steps of the claim"); *STX, LLC v. Brine, Inc.*, 211 F.3d 588 (Fed.Cir.2000) (preamble phrase "which provides improved playing and handling characteristics" followed by claim that was "self-contained description that could stand alone, with or without the preamble" held to be non-limiting preamble). If the body of the claim "fully and intrinsically sets forth the complete invention, including all of its limitations," and the preamble fails to offer a "distinct

definition of any of the claimed invention's limitations," then the preamble is not to be construed as limiting. *Pitney Bowes, Inc. v. Hewlett-Packard Co.*, 182 F.3d 1298, 1305 (Fed.Cir.1999).

[47] Where, however, preamble terms "give meaning to the claim and properly define the invention," the preamble is considered limiting. *See Paulsen*, 30 F.3d at 1479 (citation omitted). *See also General Elec. Co. v. Nintendo Co., Ltd.*, 179 F.3d 1350, 1361 (Fed.Cir.1999) (preamble reading a "system for displaying a pattern on a raster scanned display device by mapping bits from a display location in a memory associated with a computer onto the raster" was incorporated by reference because of language in claim and was held to be limiting for breathing life and meaning into claim); *Pitney Bowes*, 182 F.3d at 1306 (where term can only be understood in context of preamble statement, preamble is limiting). There exists no "litmus test" for determining the effect of a preamble. *Id.* The entire patent must be reviewed to decide whether the patentee intended for the preamble to serve as "additional structural limitations or mere introductory language." *Id.*

The preamble to Claim 34 provides: "A cutting blade assembly to be used with a surgical device that cuts at least partially across a cornea of an eye of a patient, the surgical device including a positioning ring ..., a cutting head assembly ..., and drive means ..., said cutting blade assembly comprising: ...". The preamble to Claim 53 provides: "A microkeratome blade assembly comprising: ...". The preamble to Claim 54 provides: "A cutting blade assembly to be used with a surgical device that cuts at least partially across a cornea of an eye of a patient, ..., said cutting blade assembly comprising: ...". The preamble to Claim 55 provides: "A cutting blade assembly for cutting a cornea of an eye, said cutting head assembly comprising: ...". The preamble to Claim 67 provides: "A cutting blade assembly to be used with a surgical device that cuts at least partially across a cornea of an eye of a patient ..., said cutting blade assembly comprising: ...".

[48] Plaintiff takes the position that the preambles are limiting in that these claims define blade assemblies. Defendants generally contend that the preambles are not limiting because they merely state the intended use or purpose of the invention, and the claims can stand on their own. Defendants concede that preamble 34 is partially limiting in that the claim refers back to the drive means, and preambles 54 and 67 are partially limiting in that the claims refer back to the drive assembly. The preambles at issue here define the invention because they each clearly end with the similar phrases: "said cutting blade assembly comprising: ...," "a microkeratome blade assembly comprising: ...," or "cutting head assembly comprising:..." The claims are unable to stand on their own because without the preamble it is not discernable that the elements described constitute the cutting blade or head assemblies. The patent read as a whole supports this view. I therefore conclude that the designated preambles of the '009 patent are limiting in that they refer to microkeratome cutting blade or head assemblies.

### ***G. Remaining Claim Terms not Addressed at Oral Argument***

As stated above, the parties submitted briefing on over twenty-five additional terms. The parties seem to agree on the construction for three of these terms-means for engaging, (Claim 53 of the '009 patent), means for lockingly engaging, (Claim 34(c) of the '533 patent), and positioning ring, (Claims 1 and 48(a) of the '456 patent, Claim 14 of the '553 patent, Claim 30(a) of the '009 patent and Claims 3(a), 9(a), 10(a), 14(a) and 15(a) of the '649 patent),FN18 and this Court will therefore not engage in any further analysis.FN19 I agree with plaintiff that the following terms are not in need of construction because, as plaintiff observes, they are not in dispute FN20: cutting head assembly (Claim 1(c) of '456 patent), rigid upstanding member (Claim 8 of '456 patent), cavity adapted to receive a cornea (Claim 14 of '553 patent), aperture (Claim 14 of '553 patent), head movably disposed (Claim 14 of '553 patent), rear, training portion (Claim 34(a) of '009 patent), and coupling element (Claim 53 of '009 patent). I agree with plaintiff that the following terms are clear on their face, and defendants have either failed to propose a construction which clarifies the term beyond that plain meaning or have failed to provide adequate argument including meaningful citation to the intrinsic record, and therefore these terms will not be construed by this Court: cutting element (Claim 1(c) of the '456 patent), driven across (Claim 1(c) of '456 patent), near a tip of said positioning ring (Claim 9 of '456

patent), threaded aperture (Claim 41 of '456 patent), and structured to receive and maintain (Claim 19 of '456 patent and Claim 30(e) of the '009 patent). I now address those remaining terms which are in need of judicial construction.

FN18. The term positioning ring appears in a multitude of other claims as well.

FN19. The parties agree that a means-plus-function analysis applies to the terms means for engaging and means for lockingly engaging. They also agree on the corresponding structure for these claim terms. They appear, however, to be in slight disagreement on the function. Plaintiff argues that because the parties agree on the structure, this Court need not construe the terms. Defendants offer no response to this position. I thus conclude that no construction is necessary.

FN20. I find it important that defendants offered no response to this argument.

### **1. Claim 52 of the '456 patent**

[49] Plaintiff contends that Claim 52 of the '456 patent has a typographical error in that it is missing the word "comprises" or "includes," and moves this Court to fix the alleged error. 35 U.S.C. s. 255 provides:

Whenever a mistake of a clerical or typographical nature, or of minor character, which was not the fault of the Patent and Trademark Office, appears in a patent and a showing has been made that such mistake occurred in good faith, the Director may, upon payment of the required fee, issue a certificate of correction, if the correction does not involve such changes in the patent as would constitute new matter or would require re-examination. Such patent, together with the certificate, shall have the same effect and operation in law on the trial of actions for causes thereafter arising as if the same had been originally issued in such corrected form.

Thus, this statutory provision governs the correction of typographical errors. *See In re Arnott*, 19 U.S.P.Q.2d 1049, 1052 (Comm'r Pat. & Trademarks 1991). Plaintiff has brought forth no case in which a court has taken on this role specifically assigned to the patent office. In fact, plaintiff offers no argument with respect to the impact of this statutory provision on its position before the court. I therefore conclude that this Court will not construe the claim to insert plaintiff's choice of any purportedly mistaken omission.

### **2. Means for Temporary Attachment**

[50] Claim 1(a) of the '456 patent reads: "a positioning ring have means for temporary attachment to a portion of the eye surrounding the cornea to be cut." The parties agree that s. 112, para. 6 applies. As proposed by plaintiff, the proper function, as construed from the claim language, is to "temporarily attach the positioning ring to a portion of the eye surrounding the cornea to be cut." The specification of the '456 patent provides:

Ideally, the temporary attachment means include suctioning means. For example, positioning ring 32 preferably includes a connection member 37, which ... is in fluid communication with an undersurface of positioning ring 32. Connection member 37 is adapted to be interconnected with a vacuum hose (not shown) which in turn may be connected to a vacuum means (also not shown) such that when suction occurs, the undersurface of positioning ring 32 forms a seal about and is retained about the cornea portion of the eye which is about to undergo surgery.... Typically, a vacuum of about 25 inches of Hg at sea level will be used.



Col. 7, lns. 13-23, 26-27.FN21 The parties agree that the corresponding structure includes a connection member 37. Plaintiff argues that under *Asyst*, the vacuum means and vacuum hose should not be included in the corresponding structure because these elements merely enable the attachment, but do not perform the function of attaching. This Court disagrees. The only embodiment provided in the written description is one where the temporary attachment occurs through suctioning means. Thus, the creation of the suction through the vacuuming performs the function of temporarily attaching. The vacuum means and vacuum hose are not merely enablers, but actually perform the function and therefore are part of the corresponding structure. Defendants argue that the corresponding structure also includes a "tear-drop shaped positioning ring." This Court reads the specification to include the undersurface of positioning ring 32 in the structure. The issue of the shape of the positioning is discussed *infra*.

FN21. In determining the corresponding structure to the function of this temporary attachment, this Court found Figures 5A and 5B of the '456 patent useful. (App. at i.)

### **3. At least Partially Received**

[51] Claim 1(c) of the '456 patent provides: "said cutting head assembly being structured and disposed to be at least partially received in said guide means." Defendants propose the following construction: "a portion of the cutting head assembly that goes inside the guide means." (Def. Br. at 44.) Plaintiff objects to the insertion of the word "inside." The ordinary meaning of "received" in, however, would include "to act as a receptacle or container for" and "to permit to enter." *Merriam-Webster's Collegiate Dictionary* available at <http://www.m-w.com>. Thus, the inclusion of the word "inside" does not mean that this Court would be giving the claim term something other than its ordinary meaning. This Court has not been directed to any portion of the specification or the prosecution history which would indicate a different construction. I therefore conclude that this term is construed to mean: a portion of the cutting head assembly that goes inside the guide means.

### **4. Means for Permitting Movement** FN22

FN22. This term relates to the coupling member construction discussed *supra*.

[52] Claim 1(e) of the '456 patent provides: "a coupling member ... including means for permitting movement of said cutting head assembly relative to said positioning ring along said generally arcuate path." The parties agree that this is a means-plus-function claim. The function is quite clear from the claim. To reiterate, it is permitting movement of the cutting head assembly relative to the positioning ring along an arcuate path. I conclude that it is significant that the function is one of "permitting" and not actually "doing." In other words, the disclosed structure which is clearly linked to allowing movement is part of the corresponding structure. The disclosed structure need not actually perform the movement itself.

The specification of the '456 patent provides as follows:

Coupling member 90 is structured and disposed to movably couple the cutting head assembly 50 to the positioning ring 32 *while simultaneously permitting movement of the cutting head assembly 50 relative to positioning ring 32*. As illustrated in FIG. 6, coupling member 90 comprises two segments: a) a retaining segment 92 and b) a pivot segment 95.... Thus, in assembled form, coupling member 90 is securely yet removably coupled to head assembly 50 as a result of the engagement of the driving means 80 with the housing 51 through retaining segment 92. Turning to pivot segment 95 ..., it is structured and disposed to be coupled to rigid upstanding member 44 of the positioning ring 32 and to *permit coupling member 90, and accordingly, the cutting head assembly 50 connected thereto, to pivotally move about post member 45*.

Col. 8, Ins. 60-66; Col. 9, Ins. 8-16 (emphasis added).FN23 Defendants argue that both the retaining segment 92 and the pivot segment 95 should be included in the corresponding structure of the means for permitting movement. The specification, however, discloses that it is only the pivot segment 95, and not the retaining segment 92, which performs the function of movement (by pivoting about the post member). The retaining segment is not clearly linked to that function. The written description further reads: "It will therefore be appreciated that in assembled form, the engagement means 98 and maintaining means 46 cooperate to permit coupling member 90 and cutting head assembly 50 to rotate about upstanding member 44." Col. 9, Ins. 35-40. Thus, despite plaintiff's objection to the contrary, the specification clearly provides that engagement means 98 and maintaining means 46 perform the function of permitting movement.

FN23. In determining the corresponding structure for permitting movement, this Court found Figures 5C and 6 of the '456 patent useful. (App. at i.)

In addition, the disclosed embodiment of the pivot segment, "includes a bushing 97 having a bore 96 formed therein, which is sized to receive a substantial height of post member 45, thereby captivating it therein." Col. 9, Ins. 17-20. These elements of the pivot segment thus seize the post member which is part of the function of *permitting* movement. The disclosed embodiment of the maintaining means, which "maintain[s] rigid upstanding member 44 within bushing 97," Col. 9, Ins. 22-23, and includes "an enlarged head 47 ..., and an annular recess 48 or taper about the neck section of the upstanding member 44," Col. 9, Ins. 26-28. Thus the engagement means functions to permit movement by keeping the upstanding member within the bushing through the enlarged head and an annular recess or a taper. These two elements are therefore part of the function, but the specification discloses either a annular recess or a taper. The engagement means includes a rotating handle 99 which engages the upstanding member and "cause[s] a tip thereof to extend into the annular recess 48, thereby preventing removal of the pivot segment 95 from the upstanding member 44, when surgery is to take place." Col. 9, Ins. 32-35. Thus, the handle prevents the pivot segment from becoming dislodged, and permits movement by preventing movement from stopping.

In summary, the function for the means-plus-function claim term "means for permitting movement" is to permit movement of the cutting head assembly relative to the positioning ring along an arcuate path. The corresponding structure includes: pivot segment 95, which includes bushing 97 and bore 96, engagement means 98, which includes rotating handle 99, and maintaining means 96, which includes enlarged head 47 and either an annular recess 48 or a taper. It does not include retaining segment 92.

## **5. Channel Member** FN24

FN24. This term relates to the terms "at least partially received" and "guide means" discussed *supra*.

[53] Claim 6 of the '456 patent depends on claim 1 and reads: "... wherein said guide means of said positioning ring comprise a channel member disposed on said positioning ring and extending at least partially there across." Defendants offer the following construction: "a groove formed on the upper surface of the positioning ring into which a portion of the cutting head assembly fits." (Defs.' Br. at 46.) Plaintiff claims this construction is improper and accuse defendants of attempting to limit the channel member to an "L" shaped structure when the specification provides for a "C" shaped structure that includes no "groove." As discussed, *supra*, in the context of determining the corresponding structure for guide means and guide assembly, the only embodiment disclosed in the specification is a channel member with a toothed track which mates with the propulsion shaft to guide the cutting head assembly in an arcuate path. It is the teeth of this channel (combined with the power transmitted thereto) which form the heart of the guiding process. This is true whether the channel member is "C" shaped or "L" shaped. In terms of the "C" shaped structure,

the written description of the '456 patent provides: "Thus, guide means 40 in the form of a generally 'C' shaped channel member 42 is comprised by the combined structure of sidewall 36 and toothed track 43." Col. 8, lns. 1-3. As discussed above, however, the channel member need not be formed on the upper surface of the ring; rather, it extends along at least one side of positioning ring. The question of whether a portion of the cutting head assembly fits into a groove of the toothed track was also discussed above where this Court construed "at least partially received" to mean: a portion of the cutting head assembly that goes inside the guide means. I therefore conclude that the proper construction for the term channel member is: a groove formed along at least one side of positioning ring into which a portion of the cutting head assembly fits.

## **6. Generally Tear Drop Shape**

[54] Claim 7 of the '456 patent provides: "said positioning ring has a generally tear drop shape." Defendants propose the following construction, "having a globular form at the bottom, tapering to a point at the top" and present little if any argument in support of this proposal. (Def.' Br. at 47-48.) Plaintiff counters with substituting "point at top" with "narrower portion at the top." (Pl.'s Reply Br. at 39.) Plaintiff points out that Figure 5-A, (App. at i), which illustrates an embodiment of the positioning ring, indicates that the positioning ring does not have a point at the top. Thus, defendants' construction would impermissibly exclude the preferred embodiment. *See Vitronics*, 90 F.3d at 1583-84. Neither party presents, nor could this Court find, a dictionary definition of "tear drop" which indicates whether the ordinary meaning of the word must include a pointed top. The claim itself also indicates that the shape is "generally tear drop." I therefore conclude that plaintiff has presented the construction which is consistent with the claim language and specification. Thus, the claim is not limited by a pointed top as described by defendants. Thus the proper construction for "generally tear drop shape" is: having a globular form at the bottom, tapering to a narrower portion at the top.

## **7. Generally Vertical Orientation**

[55] Claim 18 of the '456 patent provides: "A surgical device as recited Claim 1, wherein said drive means are operably connected to said cutting head assembly through a top surface thereof so that said drive means are disposed in a generally vertical orientation." Defendants propose the term to mean: "over and perpendicular to the top surface of the cutting head assembly." (Def.' Br. at 50.) Plaintiff proposes the term to mean: "vertically away from the plane of the eye in which the positioning ring is horizontally disposed." (Pl.'s Reply Br. at 40.) Thus plaintiff appears to object to defendants' construction with respect to the insertion of the word "perpendicular," as well as the extension from the "top surface."

According to the dictionary, the ordinary meaning of the word vertical is "perpendicular to the plane of the horizon or to a primary axis" and "located at right angles to the plane of a supporting surface." *Merriam-Webster's Collegiate Dictionary* available at <http://www.m-w.com>. Thus, inclusion of the word perpendicular does not change the ordinary meaning of the word vertical.

Plaintiff contends that the specification, prior art and expert testimony from the defendants' expert support its view that the extension is from the plane of the eye and not the top surface of the cutting head assembly. The language of the claim itself, however, indicates that the extension comes from the top surface of the cutting head assembly. A description denoting the plane of the eye is not included in the claim.

Nor is the plane of the eye included in that portion of the written description highlighted by plaintiff. Rather, the specification of the '456 patent reads: "the drive means 80 are thereby permitted to enter the cutting head assembly 50 through the top surface 56' and are thus, generally vertically disposed. It is believed that this feature results in less interference with the surgical field and facilitates finer handling by the surgeon than is offered by conventionally known microkeratomes. Specifically, known microkeratomes have typically provided for horizontally disposed drive means." Col. 13, ln. 64-Col. 14, ln. 4. Thus, the written description

supports the construction that the extension comes from the top surface of the cutting head assembly, not the plane of the eye. The prior art citation merely indicates that the inventor changed the horizontal direction to a vertical direction.

Plaintiff points to the following deposition testimony of Dr. Steinert, the defense expert:

Q. Do you understand what's meant by "generally vertical orientation"?

A. Yes.

Q. What does that mean to you?

A. Going up and down.

Q. With respect to the eye or with-

A. Well, the way it's used, yes, it ends up being that way, but what it really would refer to is orientation relative to the head and how it passes across the ring.

(Dep. at 117-18, Pl.'s Ex. 14.) Thus, Dr. Steinert testified that the extension from the plane of the eye is mere happenstance, but that the term refers to the extension from the cutting head assembly. I therefore conclude that neither the intrinsic nor extrinsic evidence demonstrates that the ordinary meaning of the claim language is varied. Thus, the defendants' construction of the term is correct, and "generally vertical orientation" shall be construed as: over and perpendicular to the top surface of the cutting head assembly.

### ***8. Access Means for Accessing***

[56] Claim 21 of the '456 patent provides: "A surgical device as recited in claim 19, further comprising access means for accessing said cutting element within said interior chamber of said main housing." The parties agree that the term is a means-plus-function clause. The function is clear from the claim language; it functions to access the cutting element within the interior chamber of the main housing. As to the corresponding structure, the specification of the '456 patent provides:

Additionally, in order to permit a used cutting element 70 to be removed and replaced, housing 51 includes access means 55. Although the access means 55 may include an exterior slot or like access, in the preferred embodiment, and as illustrated in FIG. 8, access means 55 at least partially form bottom wall of housing 51 near rear end face 54, and ideally, comprise a door member 57 which is hingedly connected to surrounding sidewall structure 53 at rear end face 54.

Col. 10, Ins. 16-24.FN25 Plaintiff argues that this written description includes three embodiments: an exterior slot or like access, a bottom wall and "ideally" a door. While it is true that where the specification describes more than one embodiment, the structure of the claim element must embrace each embodiment, *see Micro Chem., Inc. v. Great Plains Chem. Co., Inc.*, 194 F.3d 1250, 1258 (Fed.Cir.1999), I conclude that the specification encompasses two, not three, embodiments. As shown in Figures 6 and 8 the bottom wall of housing 51 near rear end face 54 works with the door member 57 to allow for the access to occur. There are not separate and alternative means shown. Sidewall structure 53 functions to enable the door to work; thus it does not actually perform the function of accessing. In summary, I conclude that the function of "access means for accessing" is: to access the cutting element within the interior chamber of the main housing, and the corresponding structure includes either an exterior slot or like access, or a bottom wall near rear end face 54 and a door member 57.

FN25. In determining the corresponding structure for accessing the cutting element, this Court found Figures 6 and 8 of the '456 patent useful. (App. at i, iii.)

## **9. Worm Gear**

[57] Claim 42 of the '456 patent provides: "A surgical device as recited in Claim 41, wherein said driving means are operably connected through said threaded aperture to a worm gear positioned and disposed within said main housing so as to transmit motion thereto." Defendants argue that this term should be construed as "a gear whose threads wind up in a spiral fashion with a single continuous groove around the outside of the gear." (Defs.' Br. at 54.) Plaintiff explains that defendants have confused the worm gear for the worm, noting that worm is defined as "[a] shank having at least one complete tooth (thread) around the pitch surface; the driver of a worm gear," while worm gear is defined as "[a] gear with teeth cut on an angle to be driven by a worm; used to connect nonparallel, nonintersecting shafts." (Pl.'s Reply Br. at 45) (citing *McGraw-Hill Dictionary of Scientific and Technical Terms* 2176 (5th ed. 1991)). The specification of the '456 patent supports these definitions: the "screw-like threaded surface of the worm 115 ... successively engage the drive recesses on the worm gear 120 to effect rotation thereof." Col. 14, lns. 64-67. Figure 11 of the '456 patent further demonstrates that it is the worm that includes the continuous spiral. I therefore conclude that the term worm gear shall be construed as consistent with its normal dictionary definition: gear with teeth cut on an angle to be driven by a worm, and is used to connect nonparallel, nonintersecting shafts.FN26

FN26. Worm is construed as: a shaft with at least one complete tooth or thread around its surface such that when it rotates, it drives the worm gear.

## **10. Means for Retaining and Positioning**

[58] Claim 48 of the '456 patent reads: "An automated surgical device for surgically cutting a cornea portion of the eye, said device comprising: a) means for retaining and positioning the eye on which cutting of the cornea is to be performed, said means being capable of temporary attachment to a portion of the eye surrounding the cornea being capable of exposing and presenting the cornea to be cut." The parties agree that the term is a means-plus-function clause. The function is evident from the claim language: it retains and positions the eye on which cutting of the cornea is to be performed. The corresponding structure is determined from the written description of the '456 patent which provides: "The retaining and positioning means 30, which may be made of high grade stainless steel, preferably comprise a positioning ring 32 having an aperture 33 formed therein." Col. 7, lns. 1-4.FN27 Thus, the specification discloses a positioning ring 32 with an aperture 33 to perform the retaining and positioning function. Defendants seek to include in the corresponding structure a teardrop-shaped positioning ring. While the specification does disclose such a shape, it does not specify that the particular disclosed shape performs the function of retaining and positioning the eye. Rather, it demonstrates that a ring with an aperture performs the function. I therefore conclude that such a limitation is not warranted for this means-plus-function clause. In summary, the means-plus-function claim term "means for retaining and positioning" has a function of: it retains and positions the eye on which cutting of the cornea is to be performed, and the corresponding structure includes a positioning ring 32, which is not limited by a teardrop-shape, with an aperture 33.

FN27. In determining this corresponding structure, this Court found Figure 5B of the '456 patent useful. (App. at i.)

## **11. If Said Operation of Said Vacuum Pump is Interrupted**

[59] Claim 14 of the '553 patent provides: "a reserve vacuum assembly coupled to said positioning ring to sustain the vacuum within said cavity if operation of said vacuum pump is interrupted as the head moves across the aperture." FN28 Defendants request that this court construe the term to mean: "the trigger for using the reserve vacuum assembly is interruption of the operation of the vacuum pump." (Defs.' Br. at 59.) Plaintiff objects to the use of the word "trigger," and contends that: "To the contrary, in the preferred embodiment, the reserve vacuum assembly is a vacuum tank that 'maintains' the vacuum *upon pump failure*-it need not be 'triggered' by interruption of the operation of the vacuum pump." (Pl.'s Reply Br. at 48) (emphasis added). This argument, however, supports the insertion of the word trigger. In other words, even according to plaintiff's own contention, the tank of the preferred embodiment only maintains the vacuum in the event that the pump fails and thus the operation of the vacuum pump is interrupted as recited in the claim language. The inverse of that conclusion is that unless and until the pump fails, the vacuum is not maintained by the reserve tank. Thus the trigger for the maintenance of the vacuum by the reserve tank is in fact the failure of the pump to operate. The specification of the '553 patent does not indicate otherwise: "[I]n the event that the operation of the vacuum pump is interrupted, such as due to a power loss, the reserve tank 215 is preferably structured to maintain a sufficient vacuum to continue the positioning ring's hold on the eye until the movement of the cutting head assembly 50 over the eye is completed." Col. 19, lns. 10-15. I therefore conclude that defendants have proposed an accurate construction of the term: the trigger for using the reserve vacuum assembly is interruption of the operation of the vacuum pump.

FN28. This Court above construed the term "reserve vacuum assembly" to mean: "the structure, including but not limited to a tank, to one of ordinary skill in the art that is a reserve source of vacuum."

## **12. Rear Edge**

[60] Claim 34(a) of the '009 reads: "a cutting blade having ... ii) a rear, trailing portion including a rear edge." Defendants request that the term rear edge be construed as consistent with its dictionary definition: "a line where the rear of the blade ends or begins." (Defs.' Br. at 63.) Defendants note that edge is defined as "the line where something ends or begins." ( *Id.*) (citing *Webster's New World Dictionary* 443 (2d ed. 1986)). While this definition is accurate, the term edge is also defined as "the narrow part adjacent to a border," "a point near the beginning or the end," and "a line or line segment that is the intersection of two plane faces (as of a pyramid) or of two planes." *Merriam-Webster's Collegiate Dictionary* available at <http://www.m-w.com>. Defendants offer no real argument in support of their position, and I conclude that their construction is unconvincing.

Plaintiff asks this Court to adopt the construction given by the United States District Court for the Central District of California in a related action: FN29 "having a margin of intersection between the top and bottom surfaces of the blade in which at least some part of the surface boundary defined by that margin is at the rearmost point of the blade. There is no limitation on the shape of the surface boundary defined by the margin of intersection." (Pl.'s Reply Br. at 50 (citing *Bausch and Lomb, Inc. v. Oasis Med., Inc.*, CV 00-11298 (C.D.Cal. July 18, 2001) (slip op.); Pl.'s Ex. 8.)) The Court in *Oasis Medical*, upon rejecting both proposed definitions, noted first that the blade includes three types of edges: the rear edge, the cutting edge, and the side edge. The Court further noted that the term "rear edge" has dual meaning in that the term is physical because it describes a location (within the rear, trailing portion), and it is relational because, as explained in the preferred embodiment, it is " 'generally parallel to the forward cutting edge.' " *Oasis Med.* at 4 (quoting Col. 11, lns. 26-28). The Court determined that the relational description would be meaningless unless the patentee intended to describe "the two dimensional relationship between the front and rear surface borders." *Id.* (emphasis omitted). The Court further observed that the rear edge had no shape restriction. *See id.* I am persuaded by the thorough logic of the Court in *Oasis Medical* and adopt it here.FN30 In summary, the term "rear edge" is construed as: having a margin of intersection between the top and bottom surfaces of the blade in which at least some part of the surface boundary defined by that

margin is at the rearmost point of the blade; there is no limitation on the shape of the surface boundary defined by the margin of intersection.

FN29. This related action was brought by plaintiff against a different defendant and appears to exclusively involve the '009 patent.

FN30. In reaching this conclusion, this Court also found Figures 6-B and 7 of the '009 patent useful.

### ***13. Generally Vertical Plane***

[61] Claim 67(b) of the '009 patent provides: "... said blade holder structured to be operably driven by the drive assembly of the surgical device from a generally vertical plane." Defendants propose the following construction for this term: "driving force is applied from a vertical plane." (Defs.' Br. at 68.) Plaintiff contends that this term should be construed similarly to the term "generally vertical orientation" of Claim 18 of the '456 patent which this Court, over objection by plaintiff, construed to mean: "over and perpendicular to the top surface of the cutting head assembly." For the same reasons that this Court refused to accept plaintiff's argument that the extension should come from "the plane of the eye" in the earlier construed term, this Court rejects plaintiff's attempt to do the same with this term. I therefore conclude that defendants have offered the appropriate construction for this term, and the term "generally vertical plane" is construed as: driving force is applied from a vertical plane.

### **III. CONCLUSION**

The foregoing constitutes the Court's construction of the terms presented by the parties from the claims designated in connection with the *Markman* hearing.

An appropriate Order follows.

### ***ORDER***

**AND NOW**, this 16th day of April, 2002, upon consideration of the briefs, exhibits, expert reports and deposition testimony, as well as oral argument presented by the parties in connection with the *Markman* hearing held on December 18, 2001, in which counsel for all parties participated, and upon consideration of the intrinsic and extrinsic records of the patents-at-issue as indicated in the foregoing Memorandum, it is hereby **ORDERED** that the meaning and scope of the patent claims asserted to be infringed and presented by the parties for construction are hereby determined as set forth in the foregoing Memorandum.

### **APPENDIX**

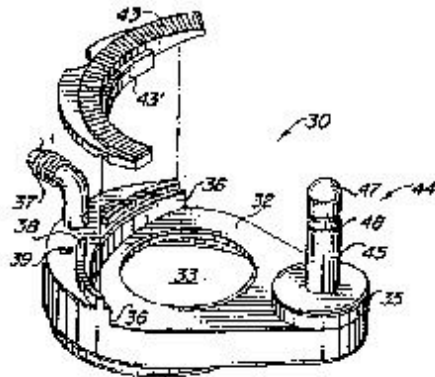

FIG. 5B

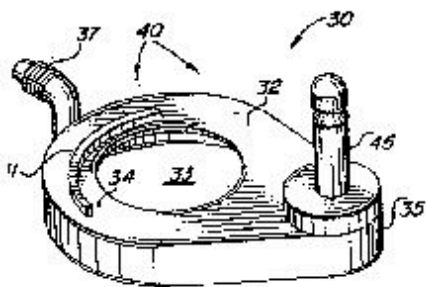

FIG. 5A

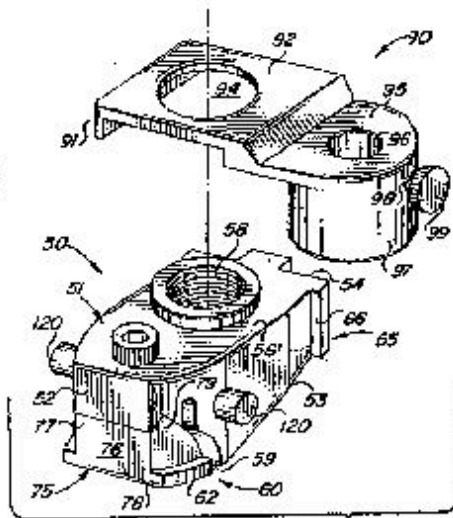

FIG. 6

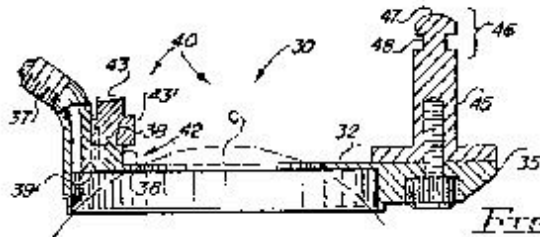
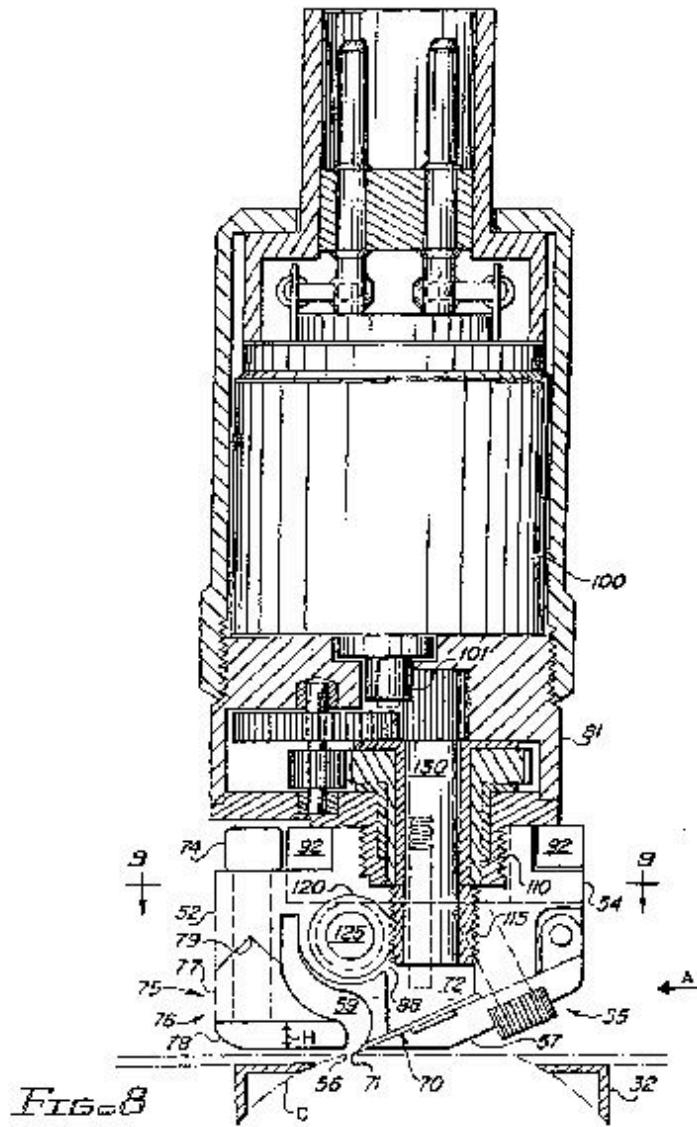

FIG. 5C



**\*661**



\*662

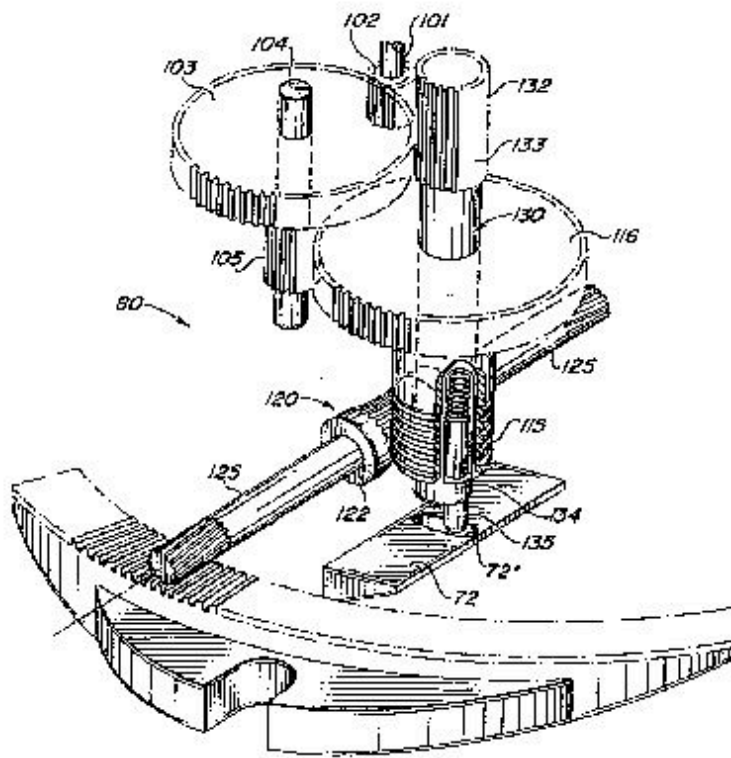
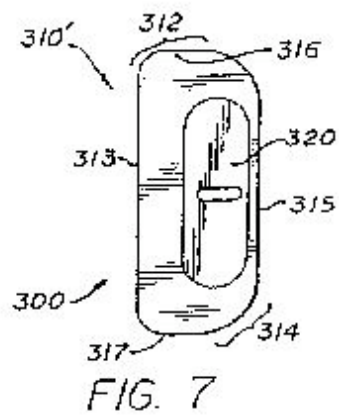
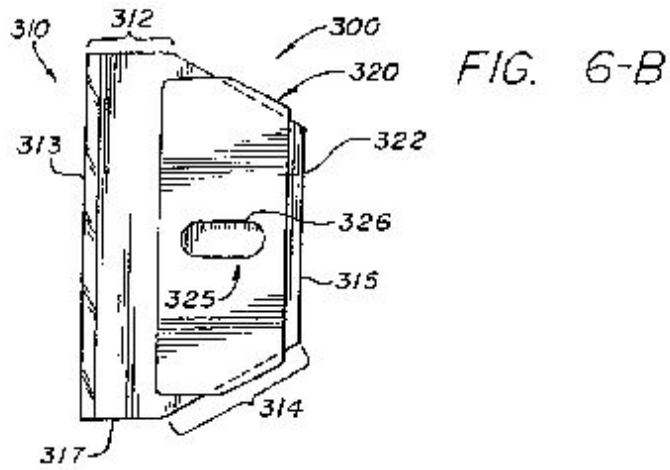
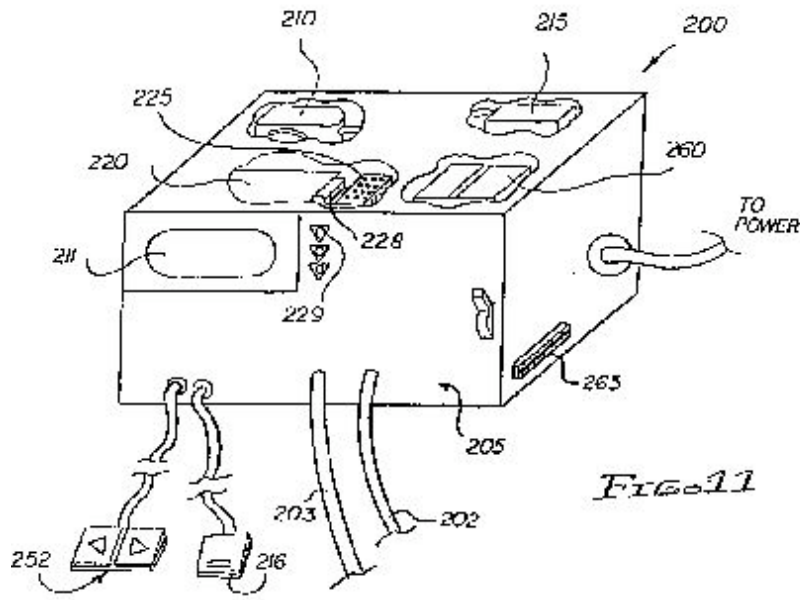

FIG. 11

\*663



\*664



\*665



USC05624456A

United States Patent (19)  
Hellenkamp

(11) Patent Number: 5,624,456  
(12) Date of Patent: Apr. 29, 1997

(14) AUTOMATIC SURGICAL DEVICE FOR CUTTING A CORNEA  
(15) Inventor: Johann F. Hellenkamp, 7740 SW 75th Ter., Miami, Fla. 33143

5,464,417 11/1995 Fink ..... 606/166  
5,446,168 11/1995 Smith ..... 606/166  
5,349,622 01/1995 Ingers ..... 606/166

OTHER PUBLICATIONS

Stetway Instrument Company, Inc., "The Stetway/Berzinger In-Situ Microkeratome Set" Brochure.  
"New Methods in Refractive Corneal Surgery—An Experimental Study," by J. Dräger et al., *Klin. Mbl. Augenheilk.* 192 (1983), pp. 458-461.  
"A Semi-Automatic Electric Keratome for Lamellar Corneal Graft," by J. Dräger, *Klin. Mbl. Augenheilk.* 189 (1975), pp. 333-339.  
"Lamellar Refractive Keratoplasty," *Bowen Eye Institute*, 1968, 1969, Chapter 4, pp. 1-9.

Priority Examiner—Guy V. Tucker  
Assistant Examiner—Mark S. Lomasolo  
Attorney Agent or Firm—Malloy & Malloy, P.A.

(57) ABSTRACT

A surgical device for cutting substantially across a cornea of an eye of a patient, the device including a positioning ring structured to be temporarily attached to a portion of the eye surrounding the cornea to be cut, and defining an aperture sized to receive and expose the cornea to be cut. The surgical device further includes a cutting head assembly structured to be guided and driven over an upper surface of the positioning ring in a generally arcuate path, and having a cutting element positioned therein and structured to oscillate laterally to facilitate approach and effective cutting of the cornea. The cutting head assembly is structured to be detachably coupled to the positioning ring by a coupling member which permits movement of the cutting head assembly relative to the positioning ring along the generally arcuate path, but maintains sufficient engagement therewith to ensure that smooth, steady, drive movement is maintained.

53 Claims, 7 Drawing Sheets

(21) Appl. No.: 598,180  
(22) Filed: Feb. 7, 1996  
(31) Int. Cl. 6 ..... A61F 9/00  
(32) U.S. Cl. .... 606/166; 606/171; 606/172  
(54) Field of Search ..... 606/4, 5, 161, 606/166, 167, 169, 170, 171, 180, 172; 606/166

(56) References Cited

U.S. PATENT DOCUMENTS

7,967,405 01/1974 Pohl et al.  
4,173,980 10/1979 Duhin . . .  
3,225,682 07/1968 Cook et al. . .  
4,429,666 10/1984 Hagan . . .  
4,560,256 07/1987 Swings et al. . .  
4,663,770 01/1987 Holbrook et al. . .  
4,625,814 01/1987 Tanso . . .  
4,614,505 07/1987 Feyman et al. . .  
4,648,579 08/1987 Yasser et al. . .  
4,407,623 02/1989 Lieberman . . .  
4,474,570 02/1989 Kymaich et al.  
4,903,625 01/1990 Wether et al. . .  
4,849,296 07/1989 Tsujigata et al. . . 606/166  
4,937,437 03/1991 Chesbaker . . .  
5,133,726 08/1992 Bain . . .  
5,217,104 02/1993 Scharf . . .  
5,238,292 02/1994 Chiral . . .  
4,718,044 04/1994 Elmer . . .  
5,308,009 11/1994 Elmer . . .  
5,295,243 07/1995 Kilmac . . .  
5,603,335 01/1995 Lechner . . .  
5,443,517 08/1995 Stein et al. . . 606/167

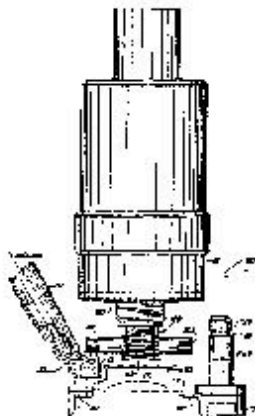

\*666

U.S. PATENT AND TRADEMARK OFFICE  
U.S. 60607553A

**United States Patent** [11]

Patent Number: 6,007,553

Hellenkamp et al.

Date of Patent: Dec. 23, 1999

[54] **AUTOMATIC SURGICAL DEVICE  
CONTROL ASSEMBLY FOR CUTTING A  
CORNEA**

5,402,315 4/1995 Loomis et al.  
5,464,417 2/1995 Eick.  
5,486,184 1/1996 Smith  
5,449,174 8/1996 Jenkins et al.  
5,284,560 12/1996 Kracker et al.  
5,283,311 10/1995 Ozono 609,106

[57] **Inventors:** Johann K. Hellenkamp, 7740 SW 75th  
Tr., Miami, Fla. 33145; Richard J.  
Sherin, 9766 SW 116th St., Miami,  
Fla. 33175

**FOREIGN PATENT DOCUMENTS**

WO 95/01143 11/1995 WPA.  
WO 96/02226 2/1996 WIPO.

**OTHER PUBLICATIONS**

1. Storz Instrument Company, Inc., "The Storzway: Endoscopic In-Situ Microkeratome Set" Brochure.
2. "New Methods in Refractive Corneal Surgery—An Experimental Study," by J. Dräger et al., *Klin. Wkbl. Augenheilk.*, 192 (1985), pp. 458-461.
3. "A Beam Automatic Electric Keratome for Lamellar Corneal Graft," by J. Dräger, *Klin. Wkbl. Augenheilk.*, 167 (1976), pp. 353-359.
4. "Lamellar Refractive Keratoplasty," *Trans. Eye Institute*, 1988, 1589, Chapter 4, pp. 1-9.

**Primary Examiner**—Michael Dritz  
**Assistant Examiner**—Wicki Trout  
**Attorney, Agent, or Firm**—Malloy & Malloy, P.A.

[21] Appl. No.: 09/065,848

[22] Filed: Apr. 24, 1999

**Related U.S. Application Data**

[63] **Continuation-in-part of application No. 08/845,171, Apr. 25, 1997, which is a continuation-in-part of application No. 08/568,190, Feb. 7, 1996, Pat. No. 5,621,426.**

[51] **Int. Cl.** ..... A61B 17/32

[52] **U.S. Cl.** ..... 606/166

[52] **Field of Search** ..... 606/166, 167,  
606/161, 165, 173, 4, 5, 1, 2; 300/272.1,  
276, 287, 293; 504/20, 22

[56] **References Cited**

**U.S. PATENT DOCUMENTS**

- Re 35,421 11/1997 Baran et al.
- 3,783,403 8/1972 Pohl et al.
- 4,173,989 11/1979 Glinis
- 4,205,682 8/1980 Crick et al.
- 4,429,696 7/1984 Ikeda
- 4,640,556 4/1987 Svingen et al.
- 4,662,370 5/1987 Thompson et al.
- 4,803,494 3/1987 Daise
- 4,874,197 3/1987 Pappas et al.
- 4,968,570 3/1987 Kracker et al.
- 5,079,829 2/1992 Liberman
- 5,086,370 12/1989 Kromach et al.
- 5,303,895 2/1994 Farmer et al.
- 4,942,596 7/1990 Funagaba et al.
- 4,471,627 8/1982 Finckh
- 5,318,432 6/1992 Swadlow et al.
- 5,123,726 7/1992 Ritz et al.
- 5,215,124 6/1993 Steiner
- 5,258,292 2/1994 Farad et al.
- 5,318,444 6/1994 Kracker et al.
- 5,318,654 1/1994 Kracker et al.
- 5,395,385 5/1995 Eick et al.

[57] **ABSTRACT**

A surgical device for cutting substantially across a cornea of an eye of a patient, the device including a positioning ring structured to be temporarily attached to a portion of the eye surrounding the cornea to be cut, and defining an aperture sized to receive and expose the cornea to be cut. The surgical device further includes a cutting head assembly structured to be guided and driven over an upper surface of the positioning ring in a generally arcuate path, and having a cutting element positioned therein and structured to oscillate laterally to facilitate smooth and effective cutting of the cornea. The cutting head assembly is structured to be detachably coupled to the positioning ring by a coupling member which permits movement of the cutting head assembly relative to the positioning ring along the generally arcuate path, but maintains sufficient engagement therebetween to ensure that smooth, steady, driven movement is maintained.

20 Claims, 10 Drawing Sheets

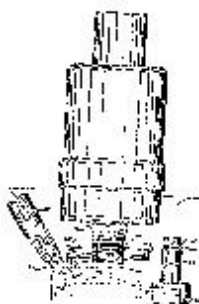

\*667

US06051009A

United States Patent 1197  
Hellenkamp et al.

(11) Patent Number: 6,051,009  
(12) Date of Patent: Apr. 18, 2000

(54) AUTOMATIC SURGICAL DEVICE FOR CUTTING A CORNEA AND A CUTTING BLADE ASSEMBLY AND CONTROL ASSEMBLY

FOREIGN PATENT DOCUMENTS

US0327 6/1994 France  
WO 95/3143 11/1995 WIPO

(70) Inventors: Johann F. Hellenkamp, 7740 SW 75th St., Miami, Fla. 33143; Richard J. Shepin, 9764 SW 110th St., Miami, Fla. 33176

OTHER PUBLICATIONS

Stearns Endoscopy Company, Inc., "The StearneyBar: "The Super Microkeratome Set" Brochure.

(\*) Notice: This patent is subject to a terminal disclaimer

(List continued on next page.)

(21) Appl. No.: 08/745,171

(22) Filed: Apr. 25, 1997

Related U.S. Application Data

(63) Continuation-in-part of application No. 08/598,180, Feb. 7, 1996, (No. 3,824,656)

(51) Int. Cl.<sup>7</sup> A61B 1/332

(52) U.S. Cl. 606/166

(58) Field of Search: 606/161, 172, 169-170, 171, 4, 5, 1, 2, 16072.1, 176, 287, 293, 604/20, 22

(56) References Cited

U.S. PATENT DOCUMENTS

- Re. 35,423 01/1977 Jure et al.
- 1,763,403 01/1971 Foll et al.
- 4,173,880 11/1979 Curtis
- 4,206,687 01/1980 Clark et al.
- 4,429,646 2/1981 Hama
- 4,661,335 07/1987 Swager et al.
- 4,662,370 09/1987 Hoffmann et al.
- 4,665,914 05/1987 Itope
- 4,671,303 01/1987 Hyman et al.
- 4,682,719 01/1987 Kramer et al.
- 4,807,823 10/1989 Lieberman
- 4,869,310 12/1989 Kofman et al.
- 4,907,655 12/1989 Wang et al.
- 4,943,296 11/1990 Pappas et al.
- 4,997,877 11/1991 Giesche
- 5,123,417 08/1992 Kozmich et al.

(List continued on next page.)

Primary Examiner—Michael Swiz  
Assistant Examiner—Vicki Trieb  
Attorney Agent, or Firm—Malloy & Malloy, P.A.

(57) ABSTRACT

An optical device for cutting substantially across a cornea of an eye of a patient, the device including a positioning ring structured to be temporarily attached to a portion of the eye surrounding the cornea to be cut, and defining an aperture sized to receive and expose the cornea to be cut. The surgical device further includes a cutting head assembly structured to be guided and driven over an upper surface of the positioning ring in a generally arcuate path, and having a cutting element positioned therein and structured to oscillate laterally to facilitate accurate and effective cutting of the cornea. The cutting head assembly is structured to be detachably coupled to the positioning ring by a coupling member which permits movement of the cutting head assembly relative to the positioning ring along the generally arcuate path, but maintains sufficient engagement therewith to ensure that smooth, steady, driven movement is maintained.

(68 Claims, 9 Drawing Sheets)

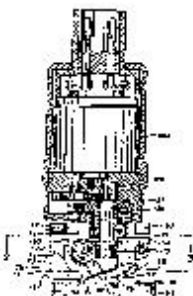





(22) United States Patent Hellenkamp

(10) Patent No.: US 6,296,649 B1 (45) Date of Patent: \*Oct. 2, 2001

(54) AUTOMATIC SURGICAL DEVICE FOR CUTTING A CORNEA

(76) Inventor: Johann F. Hellenkamp, 7740 SW 75 Ter., Miami, FL (US) 33143

(\*) Notice: Subject to any disclaimer, the term of this patent is extended or adjusted under 35 U.S.C. 154(b) by 0 days.

This patent is subject to a terminal disclaimer.

(21) Appl. No. 08/840,439

(22) Filed: Apr. 29, 1997

Related U.S. Application Data

(E3) Continuation of application No. 08/598,180, filed on Feb. 7, 1996, now Pat. No. 5,624,456

(51) Int. Cl. A61F 9/007

(52) U.S. Cl. 606/166

(53) Field of Search 606/166, 167, 606/5

(46) References Cited

U.S. PATENT DOCUMENTS

Table with 3 columns: Patent No., Date, Inventor. Includes entries like 3,542,421, 1/1967, Rufe et al., 3,583,403, 6/1971, Pohl et al., etc.

Table with 3 columns: Patent No., Date, Inventor. Includes entries like 5,215,194, 7/1993, Steiner, 5,794,557, 2/1994, Girard et al., etc.

OTHER PUBLICATIONS

- Storzway Instrument Company, Inc., "The Storzway/Esraquer Jo-Sini Microkeratome Set" Brochure. "New Methods in Refractive Corneal Surgery—An Experimental Study," by F. Draeger et al., Klin. Mbl. Augenheilk., 192 (1988), pp. 458-461. "A Semi-Automatic Electronic Keratome for Lamellar Corneal Graft," by J. Draeger, Klin. Mbl. Augenheilk., 167 (1976), pp. 357-359. "Lamellar Refractive Keratoplasty," Brien Eye Institute, 1989, 1989, Casper 4, pp. 1-9.

\* cited by examiner

Primary Examiner—Michael H. Thaler (70) Attorney, Agent, or Firm—Mallory & McCoy, P.A.

(57) ABSTRACT

A surgical device for cutting subconjunctally across a cornea of an eye of a patient, the device including a positioning ring structured to be telescopically attached to a portion of the eye surrounding the cornea to be cut, and defining an aperture sized to receive and expose the cornea to be cut. The surgical device further includes a cutting head assembly structured to be guided and driven over an upper surface of the positioning ring in a generally arcuate path, and having a cutting element positioned therein and structured to oscillate laterally to facilitate smooth and effective cutting of the cornea. The cutting head assembly is structured to be detachably coupled to the positioning ring while simultaneously permitting movement of the cutting head assembly relative to the positioning ring along the generally arcuate path.

13 Claims, 7 Drawing Sheets

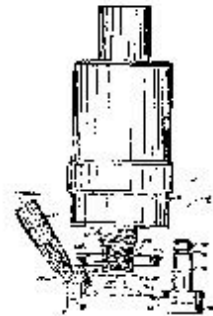

MEMORANDUM SUR MOTION FOR RECONSIDERATION OF PATENT CLAIM CONSTRUCTION

Presently before this Court is the motion of Plaintiff Bausch & Lomb Incorporated ("B & L"), for reconsideration (Document No. 65) and the response and reply thereto. For the reasons set forth below, the motion will be denied in part and granted in part.

I. Background

Johann F. "Hans" Hellenkamp is the holder of four United States patents dealing with surgical devices used to cut the human cornea during the performance of laser eye surgery ("Hellenkamp patents"). Plaintiff B & L, the exclusive licensee of the Hellenkamp patents, filed this patent infringement suit against Moria S.A. ("Moria") and Microtech, Inc. ("Microtech") alleging that defendants are infringing the Hellenkamp patents.

After holding a *Markman* hearing on December 18, 2001, this Court issued Conclusions of Law Regarding Patent Claim Construction, (Document No. 63), on April 16, 2002. *Bausch & Lomb Inc. v. Moria S.A.*, 222 F.Supp.2d 616 (E.D.Pa.2002) (hereinafter page numbers refer to the slip opinion). B & L has moved for reconsideration of this opinion.

## II. Standard

[62] [63] [64] The usual vehicle for a motion for reconsideration is Federal Rule of Civil Procedure 59(e) or 60(b). However, neither Rule 59(e) nor 60(b) applies because the order B & L seeks to have reconsidered is not a final judgment or order but rather an interlocutory decision. *See Dayoub v. Penn-Del Directory Co.*, 90 F.Supp.2d 636, 637 (E.D.Pa.2000). A federal district court has the inherent power to reconsider interlocutory orders "when it is consonant with justice to do so." *Walker by Walker v. Pearl S. Buck Foundation, Inc.*, 1996 WL 706714, at (E.D.Pa. Dec.3, 1996) (quoting *United States v. Jerry*, 487 F.2d 600, 605 (3d Cir.1973)). "[T]he purpose of a motion for reconsideration is to correct manifest errors of law or fact or to present newly discovered evidence." *Confer v. Custom Eng'r Co. Employee Health Benefit Plan*, 760 F.Supp. 75, 77 (W.D.Pa.) (quoting *Harsco Corp. v. Zlotnicki*, 779 F.2d 906, 909 (3d Cir.1985)), *aff'd in part on other grounds and dismissed in part on other grounds*, 952 F.2d 41 (3d Cir.1991); *see also Taylor v. Sterling Winthrop*, 1995 WL 752446, at (E.D.Pa. Dec.18, 1995). Because of the interest in finality, however, courts should grant motions for reconsideration sparingly. *Rottmund v. Continental Assurance Co.*, 813 F.Supp. 1104, 1107 (E.D.Pa.1992).

## III. Discussion FN1

FN1. This Court in this memorandum will refer to certain terms and law which are more fully explained and detailed in the underlying opinion. *See Bausch & Lomb Inc. v. Moria S.A.*, 222 F.Supp.2d 616 (E.D.Pa.2002).

### *Guide Assembly*

Plaintiff first argues that this Court committed clear legal error in its construction of the term "Guide Assembly." Plaintiff specifically contends that this Court failed to construe the term independently from the term "Guide Means." Plaintiff criticizes this Court for noting that the term guide means was changed to guide assembly in a later issued related patent and emphasizes that the patentee is entitled to amend or insert claims intended to cover a competitor's product. This Court did not hold that B & L was not allowed to amend the claims. Rather, this Court acknowledged that the changes in the language were superficial and not substantive.

One recognized change in the later issued '649 patent is the word change from "means" to "assembly." This word change does mean that the means-plus-function analysis does not apply. *See Al- Site Corp. v. VSI Int'l, Inc.*, 174 F.3d 1308, 1318 (Fed.Cir.1999). Where the element invokes "purely functional terms" without "recital of specific structure or material for performing that function," the claim element may nonetheless be a means-plus-function element even though the trigger word is absent. *Id.* "[T]he focus remains on whether the claim as properly construed recites sufficiently definite structure to avoid the ambit of s. 112, para. 6." *Personalized Media Communications, LLC v. Int'l Trade Comm'n*, 161 F.3d 696, 703 (Fed.Cir.1998).

A second recognized change is the addition of the word "defining" in the later issued patents. This word is also part of plaintiff's proposed construction. In the earlier '456 and '009 patents, the highlighted claims provide: "guide means ... in a generally arcuate path," (Claim 1(b) of the '456 patent and claim 30(b) of the '009 patent), and "guide means ... structured and disposed to guide said cutting head assembly along a generally arcuate path," (Claim 48(c) of the '456 patent). The later issued '649 patent provides: "said

positioning ring including a guide assembly *defining* a generally arcuate path," (Claims 3(b), 9(b), 10(b), and 15(b) of the '649 patent) (emphasis added), and "said positioning ring including a guide assembly *defining* a generally arcuate path, said guide assembly including a channel member and a post member." (Claim 14(b) of the '649 patent) (emphasis added).

In the context of discussing plaintiff's proposed construction for "guide means," this Court concluded that plaintiff's argument that guide means be construed to mean "a structure ... that defines the arcuate path" was akin to "directing an arcuate path." While defendant's proposed construction included the term "directing," this Court concluded that defining and directing were analogous based on the dictionary definitions of the term guide. ( *Supra* at 635.) Thus, this Court further concluded that the addition of the word "defining" in the '649 patent claims failed to take the term guide assembly out of the ambit of a means-plus-function analysis because the claim term connoted a function. ( *Supra* at 636.) While it was observed that Claim 14(b) of the '649 patent includes the additional structure of a channel member and a post member, this Court also concluded that the term guide assembly as recited in the '649 patent claims fall within the ambit of the means-plus-function analysis because the claim did not include sufficient structure. ( *Supra* at 636.)

Having concluded that the language in the claims of the related patents had for all substantive purposes identical meaning, this Court explained that it reached its conclusion that the guide assembly is subject to a means-plus-function analysis "for the same reasons that the term 'guide means' is subject to that analysis." (Slip Op. at 21.) While this Court did recognize the timing of the '649 patent as significant, the significance of the timing lies in the fact that the changes which were made after the plaintiff was made aware of the drafting weaknesses were cursory, not substantive, and therefore failed to take the term out of the reach of s. 112, para. 6. Thus, it was the type of changes which were made which affected this Court's construction of the guide terms, and this Court did in fact engage in a separate analysis of the "guide assembly."

[65] To be clear, the determination of whether or not s. 112, para. 6 applies is decided on an "element-by-element basis," based on the patent and its prosecution history. *Cole v. Kimberly-Clark Corp.*, 102 F.3d 524, 531 (Fed.Cir.1996) (citing *Palumbo v. Don-Joy Co.*, 762 F.2d 969 (Fed.Cir.1985), *overruled on other grounds*, *Markman*, 52 F.3d at 979 ("In construing a 'means plus function' claim, and as well other types of claims, a number of factors may be considered, including the language of the claim, the patent specification, the prosecution history of the patent, other claims in the patent, and expert testimony")). This Court's construction of guide assembly is wholly supported by the fact that while the claims in the later issued '649 patent recite the term guide assembly, the specification includes the following single reference to that term: "The retaining and positioning means 30 further include *guide means or guide assembly* 40 formed thereon." (Col.4, Ins.31-32) (emphasis added). The remaining portion of the specification refers entirely to guide means, a term which is not found in the claims. Further, that portion of the '649 patent specification which describes guide means is seemingly identical to the guide means portion of the specification of the '456 patent. Where terms are used interchangeably, this Court cannot construe them in complete isolation. *See Abtox, Inc. v. Exitron Corp.*, 131 F.3d 1009, 1010, 1010 n. 1 (Fed.Cir.1997) (where the terms "gas-tight confining chamber" and "gas-confining chamber" are found "indisputably interchangeable," and are used in various claims which have issued in separate but related patents, "it would be improper to construe this term differently in one patent than another, given their common ancestry"). FN2

FN2. Plaintiff attempts to distinguish *Abtox* on the ground that means-plus-function terms were not at issue; however, plaintiff brings forth no cases in which this rule can be wholly ignored in the context of s. 112, para. 6.

This Court is perplexed by plaintiff's contention that this Court committed clear error in construing these terms together when plaintiff uses the terms interchangeably as evidenced by the fact that plaintiff proposed that the terms be given an identical construction. I also note that plaintiff now presents a proposed

construction for the term guide assembly which is different from the construction offered at the *Markman* hearing, and I will therefore not consider it. For the aforementioned reasons, I conclude that this Court will not amend its conclusions regarding the term guide assembly.

### ***Guide Element***

[66] Plaintiff also moves for reconsideration of this Court's construction of the term "Guide Element." The highlighted claim in which guide element appears provides: "a positioning ring including a cavity adapted to receive a cornea, an aperture for exposing a portion of the cornea of the eye, and a guide element; ... said guide element guiding said head across said aperture making the lamellar incision in the cornea." (Claim 14 of the '553 patent). This Court previously determined that the function of the guide element varied from the other guide terms in that while the function of the guide means and guide assembly is to direct the movement of the cutting head assembly in an arcuate path, the function of the guide element is not to guide in an arcuate path, but to guide the head across the aperture making a lamellar incision. ( *Supra* at 636.) This Court further determined that because the specification failed to mention the term, B & L had in effect failed to particularly point out and distinctly claim the invention as required by the second paragraph of section 112. ( *Supra* at 639.)

Upon reconsideration of the claim in question, including the fact that defendant moved for the guide terms to be given one construction, this Court now concludes that the function of the "guide element" does not vary from the other guide terms. As to its structure, the specification fails to make even one mention of the term. Rather the specification refers to the "guide means," a term not found in the '553 patent claims. The portion of the '553 specification which includes a discussion of the guide means mirrors that portion of the '456 specification which includes a discussion of the guide means. ('553 patent, Col. 7 ln. 23-Col. 8 ln. 14.) I therefore conclude that the motion for reconsideration will be granted on the limited ground that the term guide element has the same construction as the terms guide means and guide assembly.

### ***Drive Assembly***

B & L next attacks this Court's construction of the term "Drive Assembly." Plaintiff argues that this Court impermissibly relied on the term as used in the '649 patent for its construction of the term in the earlier issued '009 patent. In other words, plaintiff takes the position that this Court committed legal error by looking to claims in a subsequent patent and not giving the term in the '009 patent an independent analysis. B & L contends that the term in the '009 patent should not fall within the reach of s. 112, para. 6.

The '009 patent includes the following recitations of drive assembly: "A cutting blade assembly to be used with a surgical device that cuts at least partially across a cornea of an eye of a patient, the surgical device including a drive assembly, said cutting blade assembly comprising," (Preambles of Claims 54 and 67 of the '009 patent); "a blade holder, said blade holder secured to said cutting blade and structured to be operably driven by the drive assembly of the surgical device," (Claim 54(b) of the '009 patent), and "a blade holder having an underside, said underside of said blade holder secured to said cutting blade at said at least one aperture formed in said cutting blade, and said blade holder structured to be operably driven by the drive assembly of the surgical device from a generally vertical plane," (Claim 67(b) of the '009 patent).

As provided in the underlying opinion, the preambles of Claims 54 and 67 do not include a function; however, this portion of these claims merely recite what is included in the cutting blade assembly. (Slip Op. at 34.) In other words, the claim provides no context for a construction of the term drive assembly. Rather, as further provided in the underlying opinion, Claims 54(b) and 67(b) expressly provide that the drive assembly has a clear function of driving the blade holder. ( *Supra* at 643-44.) *See Georgia-Pacific Corp. v. U.S. Gypsum Co.*, 195 F.3d 1322, 1331 (Fed.Cir.1999) ("a claim term cannot be given a different meaning in the various claims of the same patent.") (citing *Southwall Tech., Inc. v. Cardinal IG Co.*, 54 F.3d 1570,

1579 (Fed.Cir.1995)). As provided in the April 16th opinion, it was for this independent reason that this Court concluded that the '009 patent claims invoked s. 112, para. 6. It was the express function of driving the blade holder without any recitation of structure, which invoked the means-plus-function analysis. This Court further opined:

Most critical, however, is plaintiff's proposed construction: "The term "drive assembly" is a structure that connects to the cutting head assembly and imparts movement to the cutting head assembly, oscillating movement to the cutting element, or both (depending on the claim-'649 patent claim 9 recites both cutting head movement and oscillation, claim 10 recites cutting head movement, and claim 15 recites oscillation)." (Court Reference Sheet at 2.) This construction is the equivalent of the function of the drive means: causing movement of the cutting head assembly across the positioning ring and oscillating movement of the cutting element. The addition of the word structure is only a bare word which fails to include a description for such structure.

( Supra at 643-44.) I further observe that while plaintiff's proposed construction incorporates the '649 patent, it ignores the '009 patent. In addition, while the specification of the '009 patent discusses the drive means, this Court could not find reference to the drive assembly, nor does plaintiff direct this Court to any such mention of the term in the '009 specification. I therefore conclude that this Court will not amend its conclusions regarding the term drive assembly as used in the '009 patent.

### ***Structure of Drive Means and Drive Assembly***

Plaintiff next moves for reconsideration of the corresponding structure for the drive means and drive assembly terms. B & L specifically attacks two conclusions made by this Court. First, B & L argues that this Court erred in including the propulsion shaft as part of the structure. The specification of the '456 patent provides: "The propulsion shaft 125 ... is structured to ... engage the toothed track 43 on the positioning ring 32 such that upon rotation of the worm gear 120, and accordingly rotation of the propulsion shaft 125, *the propulsion shaft 125 rides along the toothed track 43 and drives the cutting head assembly 50 across the positioning ring 32.*" Col. 15, Ins. 3-10 (emphasis added). As this Court previously determined: "It could not be more transparent from quoted passage of the specification that the propulsion shaft is clearly linked to the function of driving (or moving) the cutting head assembly across the positioning ring. The written description vividly states that the propulsion shaft performs this function." ( Supra at 643.) This Court stands by its earlier conclusion.

Second, B & L contends that the court erred by concluding that because the drive components were "inextricably intertwined," the structures to accomplish the different functions had to be joined, despite the fact that the court recognized that the drive terms had dual functions. Specifically, this Court determined that the drive functions of moving the cutting head assembly and oscillating the blade are inextricably intertwined because one function cannot occur without the other function occurring. In other words, as the cutting head assembly is moved, the blade oscillates at the same precise time. The court therefore concluded that the drive means and drive assembly perform two functions and because these functions cannot occur independently, the corresponding structure is the same.

Plaintiff begins with the general well accepted principal that it is improper to include structure which does not perform the function. Plaintiff also appears to argue that this Court made an improper factual finding in determining that the functions were inextricably intertwined. B & L relies primarily on *Chiuminatta Concrete Concepts, Inc. v. Cardinal Industries, Inc.*, 145 F.3d 1303 (Fed.Cir.1998), in which the Court of Appeals held that a single structure which performs three functions must be separated. *Chiuminatta* involved the construction of the following means-plus-function clause: "supporting the surface of the concrete adjacent to the leading edge of the cutting blade to inhibit chipping, spalling, or cracking of the concrete surface during cutting." *Id.* at 1308. The specification clearly identified the structure to perform that function

as the skid plate. *See id.* The court concluded that the entire skid plate was not included in the corresponding structure because certain structural aspects of the skid plate performed different functions. *See id.*

Plaintiff contends that it is significant that defendant does not distinguish *Chiuminatta*. I conclude, however, that *Chiuminatta* is distinguishable. *Chiuminatta* involved a means clause which performed only one function: supporting a particular surface of the concrete. Here, the means terms drive means and drive assembly perform two functions, not one function. In other words, were the term associated with the single function of oscillating the blade, then only those structural components identified with that function would constitute the corresponding structure. Here, however, the interchangeable means terms are associated with two functions. Plaintiff takes the position that this Court erroneously failed to separate the structure, but the focus of the underlying opinion was on whether the functions, not the structure, were separable.

Plaintiff argues that in the present invention, the components corresponding to the two functions are not extricable because (1) they operate in perpendicular directions; (2) they act on different objects, i.e.-the blade assembly versus the cutting head; and (3) they operate at significantly different speeds or frequencies. Plaintiff does not contend, however, that the functions occur at separate times.

[67] Plaintiff further contends that this Court's construction violates the judicially created doctrine of claim differentiation because under the court's analysis, claim 48 of the '456 patent and claims 9-12 and 15 of the '649 patent have the identical scope. This Court agrees with defendant that this doctrine is merely a rebuttable presumption and does not trump the statutory requirements for claim construction. *See, e.g., Wenger Mfg., Inc. v. Coating Machinery Sys., Inc.*, 239 F.3d 1225, 1233 (Fed.Cir.2001).

I further point out that this Court did not impermissibly make a factual finding that the functions were inextricable intertwined because it is well settled that construing the corresponding structure is a matter of law. This Court notes that B & L's own proposed construction for drive assembly would have led to the same construction. Specifically, B & L had proposed that drive assembly be construed to mean: "a structure that connects to the cutting head assembly and imparts movement to the cutting head assembly, oscillating movement to the cutting element, or both (depending on the claim-'649 patent claim 9 recites both cutting head movement and oscillation, claim 10 recites cutting head movement, and claim 15 recites oscillation)." Thus, it is clear that plaintiff proposed a single structure which performs both functions.

This court thoroughly addressed the issue of the corresponding structure for the drive terms in the underlying opinion, and I conclude that I did not commit a clear error of law which is the standard to meet on this motion for reconsideration. I will therefore not amend the opinion with respect to this issue.

### ***Channel Member***

B & L also moves for reconsideration of this Court's construction of the term "Channel Member." Claim 6 of the '456 patent depends on claim 1 and provides: "... wherein said guide means of said positioning ring comprise a channel member disposed on said positioning ring and extending at least partially thereacross." This Court construed the term channel member to mean: a groove formed along at least one side of positioning ring into which a portion of the cutting head assembly fits. In so construing the term, the court noted that when examining the specification in the context of determining the corresponding structure for the guide terms, the specification disclosed only one embodiment of the channel member which actually could perform the guiding function. Specifically, this Court concluded that the specification only adequately described a channel member 42.

Plaintiff argues that in requiring the channel member to have a groove, the court excluded a preferred embodiment from the construction. Plaintiff contends that the specification defines two distinct structures: channel member 41 and 42, and that channel member 41 includes no groove. Plaintiff contends that there is

no channel member disclosed that is a groove into which a toothed track (a separate piece of structure) is added. Plaintiff also argues that it was erroneous to incorporate "at least partially received" into the court's construction because "at least partially received" is part of claim 1, not claim 6. Plaintiff offers the following construction: "a structure formed along at least one side of the positioning ring that is either a ridge forming an outer boundary for the cutting head assembly or a groove into which a portion of the cutting head assembly fits." FN3 I highlight that the second part of this proposed construction nearly mirrors the court's construction in the underlying opinion.

FN3. This construction differs from the original proposed construction: "part of the outer surface of the positioning ring that forms an arcuate path for the cutting head."

Defendant responds that plaintiff has remanufactured arguments which were already rejected by this Court. Defendant also aptly argues that it was proper to limit channel member by "at least partially received" because claim 6 is dependent on claim 1.

Plaintiff replies that defendant does not appreciate the inconsistency. Plaintiff takes the position that to the extent that the Court's channel member construction for the '456 patent claim 6 applies to the corresponding structure construction for "guide means," the composite result is: "a channel member [a groove into which a portion of the cutting head assembly fits] with a toothed track that is formed or mounted thereon."

Plaintiff has not persuaded this Court that there is any inconsistency in the court's construction of channel member. Plaintiff's own construction allows for the term to be construed as a groove into which a portion of the cutting head assembly fits. I will therefore not amend the underlying ruling.

#### **IV. Conclusion**

This Court concludes that the term guide element has the same construction as the terms guide means and guide assembly. In all other respects, the opinion rendered on April 26, 2002 remains unchanged. An appropriate Order follows.

#### ***ORDER***

**AND NOW**, this 26th day of August, 2002, upon consideration of motion of Plaintiff Bausch & Lomb Incorporated for reconsideration (Document No. 65) and the response and reply thereto, for the reasons set forth in the foregoing memorandum, it is hereby **ORDERED** that the motion is **GRANTED** in part and **DENIED** in part.

Produced by Sans Paper, LLC.