

United States District Court,
D. Connecticut.

UNITED TECHNOLOGIES CORPORATION,
Plaintiff.

v.
PERKINELMER, INCORPORATED, & Eaton Corporation,
Defendants.

No. 3:05 CV 1824(MRK)

March 24, 2008.

Background: Owner of patent relating to brush seals used in aircraft jet engines filed infringement action against competitor.

Holdings: The District Court, Mark R. Kravitz, J., held that:

- (1) claim described stand-alone brush seal, rather than brush seal assembly;
- (2) term "tab" described one that was not machined;
- (3) term "tab" was not limited to radially offset tab; and
- (4) term "lip" included protrusion or appendage that angled sharply away from tab's main body.

Ordered accordingly.

Court-Filed Expert Resumes

5,597,167. Construed.

Glenn E. Coe, Anne C. Dranginis, Kelley A. Bergelt, Rome McGuigan, P.C., Hartford, CT, Hamilton H. Hill, Paul J. Skiermont, Bartlit, Beck, Herman, Palenchar & Scott, Chicago, IL, for Plaintiff.

Glenn A. Duhl, Siegel, O'Connor, O'Donnell & Beck, P.C., Hartford, CT, James F. Kamp, Leigh C. Taggart, Michael B. Stewart, R. Terrance Rader, Steven R. Hansen, Rader, Fishman & Grauer, PLLC, Bloomfield Hills, MI, for Defendants.

Memorandum of Decision on Claim Construction

MARK R. KRAVITZ, District Judge.

In this case, Plaintiff, United Technologies Corporation ("UTC"), asserts that Defendants, PerkinElmer,

Incorporated ("PerkinElmer") and Eaton Corporation ("Eaton"), FN1 infringed UTC's United States Patent 5,597,167 (the "'167 Patent"), entitled "Brush Seal with Fool Proofing and Anti-Rotation Tab." *See* Amended Complaint [doc. # 13]. UTC's patent, which is attached to this decision as an appendix, relates to brush seals commonly used in aircraft jet engines.

FN1. UTC alleges that the replacement brush seals at issue are manufactured at a facility in Warwick, Rhode Island, which at the time of UTC's filing of suit was owned by PerkinElmer, but has since been purchased by Eaton. *See* UTC's Claim Construction Brief [doc. # 62], at 1 n. 1. All references in this ruling to "PerkinElmer" will include both PerkinElmer and Eaton.

Both parties have filed briefs on the construction of various terms in the '167 Patent, as well as motions for summary judgment on patent infringement and invalidity and motions to exclude each other's experts. However, as the parties themselves recognize, assessment of patent infringement and validity claims involves two steps, the first of which is claim construction. *Amazon.com, Inc. v. Barnesandnoble.com, Inc.*, 239 F.3d 1343, 1351 (Fed.Cir.2001). Thereafter, the construed claims are compared with the accused device to determine in the case of infringement, whether all of the claim limitations are present either literally or by a substantial equivalent, or to determine in the case of validity, "whether the claim 'reads on' an accused device or method, or whether the prior art anticipates and/or renders obvious the claimed invention." *Id.*

Therefore, this ruling is confined to the first step-claim construction. The Court will require further briefing on infringement and invalidity in light of its construction of the patent claims. Accordingly, the Court denies without prejudice the parties' motions for summary judgment. The Court also denies without prejudice the parties' motions seeking exclusion of expert testimony. The Court has been able to construe the disputed terms in the '167 Patent without the need to rely on any of the parties' proffered expert testimony. That said, the Court benefitted greatly from the superb briefing provided by both parties and by the able presentations of counsel at a Markman hearing devoted to claim construction issues. The Court is grateful to counsel for their guidance.

I. Background

Commonly used in aircraft jet engines, brush seals are hoop-like structures consisting of one or more bristle packs sandwiched between two retaining plates, in this case a sideplate and a backplate. *See* '167 Patent at 1:18-25. A brush seal provides sealing between a rotating component such as a shaft and an adjacent stationary structure. *See id.* at 1:16-18. Because the free ends of the bristles extend beyond the sideplate and backplate, the bristles maintain contact with the rotating surface, filling the air gap between the surfaces and thus forming a seal. An everyday analogy to these brush seals would be the brush or rubber seals commonly attached to the bottom of the front doors to houses to exclude air entry. In jet engines, brush seals are used to isolate high pressure regions in an engine from low pressure regions. By doing so, they allow the turbine engine to work more efficiently and also reduce damage to turbine parts.

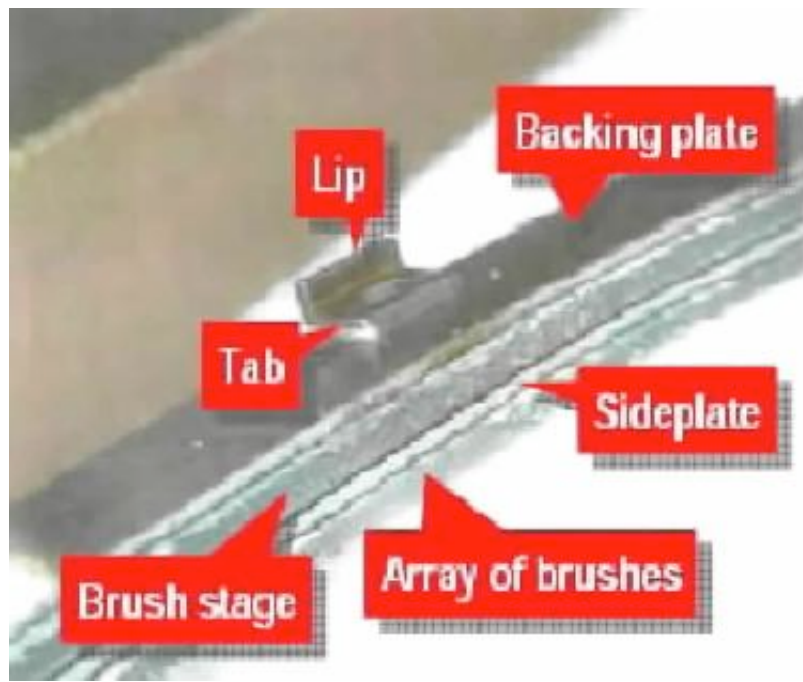

As owner of the '167 Patent, UTC does not claim to have invented brush seals. However, UTC does contend that it advanced the state of the art of brush seals. The parties agree that the ' 167 Patent is directed toward two problems in brush seal design: (1) rotation of the brush seal; and (2) reverse installation of the brush seal (also termed "foolproofing"). *See* UTC's Claim Construction Brief ("UTC's Claim Br.") [doc. # 62], at 4-8; Defs.' Claim Construction Brief ("Defs.' Claim Br.") [doc. # 61], at 4. Rotation happens when interaction between the brush seal's bristles and the rotating surface causes the seal to rotate in the direction of the rotating surface. Reverse installation occurs because it is easy to mistake the "front" of the brush seal for its "back." Both rotation and reverse installation can cause excessive wear on a brush seal, impairing its sealing performance and reducing or preventing its effectiveness. The wear from rotation results from the contact between the bristles and the rotating surface, which can eventually result in wear on both the brush seal and the stationary surface. *See* '167 Patent at 1:29-32. The wear from reverse installation results from the bending of the bristles in the wrong direction as well as the effect of higher levels of vibration when the brush seal does not seat properly. *See id.* at 1:33-46.

UTC's design-which is by no means the first to seek a solution to the problems of rotation and reverse installation-tries to eliminate these issues by way of a tab that is attached to the brush seal. The tab prevents rotation because it fits within a cut-out in a housing structure consisting (in pertinent part) of a "retaining means," which holds the brush seal to the stationary surface termed the "carrier." The tab prevents reverse installation by interfering with the carrier if it is installed backwards. UTC contends that its design advanced the state of the art because it allows for brush seals to be used "in locations of higher pressure and surface speed," and thus larger airplanes, such as the Boeing 777, "than had previously been accomplished in the industry." UTC's Claim Br. at 1. The brush seal at issue in this case has a diameter of about two feet.

II. Legal Framework

[1] [2] [3] [4] The construction of patent claims is a matter of law within the exclusive province of the Court. *See* *Markman v. Westview Instruments, Inc.*, 517 U.S. 370, 388, 116 S.Ct. 1384, 134 L.Ed.2d 577

(1996). To fulfill that responsibility, the Court must use the framework for construing patent claims developed by the Supreme Court and the Federal Circuit. In its landmark decision in *Phillips v. AWH Corp.*, 415 F.3d 1303 (Fed.Cir.2005) (en banc), the Federal Circuit provided lower courts with important guidance in construing patent claims. It explained that "the words of a claim are generally given their ordinary and customary meaning[, which] is the meaning that the term would have to a person of ordinary skill in the art in question at the time of the invention...." *Phillips*, 415 F.3d at 1312-13 (quotation marks omitted). Where such meaning is "readily apparent even to lay judges, ... claim construction ... involves little more than the application of the widely accepted meaning of commonly understood words. In such circumstances, general purpose dictionaries may be helpful." *Id.* at 1314 (citations omitted). In many cases, however, the meaning of a term is not "readily apparent" and "determining the ordinary and customary meaning of the claim requires examination of terms that have a particular meaning in a field of art." *Id.* To do so, courts should look to those sources available to the public, that is, "the words of the claims themselves, the remainder of the specification, the prosecution history, and extrinsic evidence concerning relevant scientific principles, the meaning of technical terms, and the state of the art." *Id.* (quotation marks omitted).

As to the first interpretative source-the words of the claim itself-the Federal Circuit has stated that "[i]t is a bedrock principle of patent law that the claims of a patent define the invention to which the patentee is entitled the right to exclude." *Id.* at 1312 (quotation marks omitted). Beyond the words themselves, the context in which a term is used also matters. *See id.* at 1314. In providing guidance on how a claim's terms should be read, the Federal Circuit has developed two sets of rules, among others, that are particularly relevant here-that relating to preambles and that dealing with differences in claims.

[5] [6] First, because "claims are interpreted with an eye toward giving effect to all terms in the claim," *Bicon, Inc. v. Straumann Co.*, 441 F.3d 945, 950 (Fed.Cir.2006), preamble language should also be considered in construing claims. *See id.* Though usually not limiting in nature, preamble language can be limiting in certain cases. *See id.* at 952. "Preamble language that merely states the purpose or intended use of an invention is generally not treated as limiting the scope of the claim." *Id.* However, "if the claim drafter 'chooses to use *both* the preamble and the body to define the subject matter of the claimed invention, the invention so defined, and not some other, is the one the patent protects.'" *Id.* (quoting *Bell Commc'ns Research, Inc. v. Vitalink Commc'ns Corp.*, 55 F.3d 615, 620 (Fed.Cir.1995)). "Moreover, when the limitations in the body of the claim 'rely upon and derive antecedent basis from the preamble, then the preamble may act as a necessary component of the claimed invention.'" *Id.* (quoting *Eaton Corp. v. Rockwell Int'l Corp.*, 323 F.3d 1332, 1339 (Fed.Cir.2003)).

The Federal Circuit has cautioned that "there is no litmus test for determining whether preamble language is limiting. To the contrary, ... whether to treat a preamble as a claim limitation is determined on the facts of each case in light of the *claim as a whole* and the *invention described in the patent*." *Id.* (quotation marks and citations omitted and emphasis added); *see also* *In re Cruciferous Sprout Litig.*, 301 F.3d 1343, 1347 (Fed.Cir.2002) ("Whether to treat a preamble as a limitation is a determination resolved only on review of the *entirety of the patent* to gain an understanding of what the inventors actually invented and intended to encompass by the claim." (quotation marks omitted and emphasis added)).

[7] [8] Second, "[d]ifferences among claims can also be a useful guide in understanding the meaning of particular claim terms. For example, the presence of a dependent claim that adds a particular limitation gives rise to a presumption that the limitation in question is not present in the independent claim." *Phillips*, 415 F.3d at 1314-15 (citations omitted). This concept-known as the doctrine of claim differentiation-is "a guide, not a rigid rule," *Curtiss-Wright Flow Control Corp. v. Velan, Inc.*, 438 F.3d 1374, 1381

(Fed.Cir.2006) (quotation marks omitted), and it provides that "[t]o the extent that the absence of such difference in meaning and scope would make a claim superfluous, the doctrine of claim differentiation states the presumption that the difference between claims is significant." *Andersen Corp. v. Fiber Composites, LLC*, 474 F.3d 1361, 1369-70 (Fed.Cir.2007) (quotation marks omitted). In sum, this judge-made doctrine "is based on the common sense notion that different words or phrases used in separate claims are presumed to indicate that the claims have different meanings and scope." *Id.* at 1369.

[9] The second interpretative source identified by the Federal Circuit-the specification-is often determinative of the meaning and scope of the claims. As the Federal Circuit has explained, "claims must be read in view of the specification, of which they are a part." *Phillips*, 415 F.3d at 1315 (quotation marks omitted). In fact, "[u]sually, [the specification] is *dispositive*; it is the *single best guide* to the meaning of a disputed term [and] the *primary* basis for construing the claims." *Id.* (quotation marks omitted and emphasis added). As such, where the specification reveals "a special definition given to a claim term ... that differs from the meaning it would otherwise possess" or "an intentional disclaimer, or disavowal, of claim scope by the inventor," it is "the inventor's intention, as expressed in the specification, [that is] dispositive." *Id.* at 1316 (citations omitted).

[10] However, the Federal Circuit has emphasized that while courts should use the specification to interpret claim terms, they should "avoid importing limitations from the specification into the claims...." *Id.* at 1323. For example, the "depiction of a single embodiment in a patent [does not] necessarily limit[] the claims to that depicted scope." *AGFA Corp. v. Creo Prods. Inc.*, 451 F.3d 1366, 1376 (Fed.Cir.2006) (citing *Phillips*, 415 F.3d at 1323). Rather, the specification should be used to determine whether the embodiments "define the outer limits of the claim term or [are] merely ... exemplary in nature." *Phillips*, 415 F.3d at 1323. In short, claim terms should be read in light of the specification but not limited by it, although "the distinction between using the specification to interpret the meaning of a claim and importing limitations from the specification into the claim can be a difficult one to apply in practice." *Id.*

The two remaining sources of interpretation-the prosecution history and extrinsic evidence-are useful, but less reliable, sources of a patent claim's meaning, the latter more so than the former. Thus, the prosecution history can inform the specification where needed, *see id.* at 1315, because it "provides evidence of how the [Patent and Trademark Office] and the inventor understood the patent," *see id.* at 1317. However, because a prosecution history represents an "ongoing negotiation ... rather than the final product of that negotiation, it often lacks the clarity of the specification and thus is less useful for claim construction purposes." *Id.* Similarly, although courts can rely on extrinsic evidence-that is, "all evidence external to the patent and prosecution history, including expert and inventor testimony, dictionaries, and learned treatises," *id.* (quotation marks omitted)-such evidence is "less significant" and "less reliable" than the intrinsic record (including the prosecution history) in constructing a claim. *See id.* at 1317-18. FN2

FN2. As noted, each side filed expert opinions, and objections to the use of such opinions. Given that intrinsic evidence is preferred over extrinsic evidence, *see Phillips*, 415 F.3d at 1317-18, and that the expert opinions simply tracked the arguments of counsel in the legal briefs, the Court concluded that it was able to construe the '167 Patent without resorting to the views of the parties' experts. As a result, the Court need not address each side's efforts to prevent the other side's experts from testifying.

In sum, therefore, it is "[t]he construction that stays true to the claim language and *most naturally aligns with the patent's description of the invention* [that] will be, in the end, the correct construction." *Id.* at 1316

(quoting *Renishaw PLC v. Marposs S.p.A*, 158 F.3d 1243, 1250 (Fed.Cir.1998) (emphasis added)). As in many cases, the parties do not dispute these general principles. It is their application in the context of this case that causes disagreement. And it is to their application that the Court now turns.

III. Analysis

The '167 Patent describes UTC's inventions in eighteen claims. Claims 1, 7, and 13 are the only independent claims, with claims 2 through 6 dependent on claim 1, claims 8 through 12 dependent on claim 7, and claims 14 through 18 dependent on claim 13, which covers a method of installation and is not at issue in this ruling. UTC's claims of patent infringement involve only claims 1, 3, and 6. Those claims are reproduced below, with the disputed language italicized:

1. *A brush seal for discouraging fluid flow through an annular spacing between a stationay [sic: stationary] carrier and a rotating surface proximate to the carrier, the annular spacing disposed about a longitudinal axis and separating a first cavity and a second cavity, the first cavity having a higher pressure than the second cavity, the carrier including a retaining means being engageable with the brush seal and thereby fixedly retain the brush seal to the carrier with the brush seal in an installed condition, the brush seal including:*

at least one brush stage, the brush stage including:

an array of brushes extending through the spacing;

a backing plate adjacent the side of the array of brushes, the backing plate facing the second cavity with the brush seal in the installed condition; and

a sideplate adjacent the opposite side of the array of brushes; and

a *tab* disposed in a fixed relationship to the brush stage, the *tab* engaging the *retaining means* to block rotation of the brush stage about the longitudinal axis, and the *tab* extending outward from the brush seal, the *tab* being located such that if the brush seal is installed with the backing plate between the array of brushes and the first cavity, the *tab* interfaces with the carrier to thereby prevent fixed retention of the brush seal to the carrier by the retaining means.

...

3. The brush seal according to claim **1**, wherein the *retaining means* is vane assembly sideplate, the vane assembly sideplate being fastened to an adjacent vane assembly and extending over the brush seal, wherein the *tab* is disposed on the side of the brush seal facing the second cavity.

....

6. The brush seal according to claim **3**, wherein the *tab* includes a *lip* extending outward from the brush seal, wherein the vane assembly sideplate includes a cut-out adapted to accommodate the *lip* such that engagement between the *lip* and cut-out blocks rotation of the brush seal about the longitudinal axis.

U.S. Patent No. 5,597,167, at 6:5-29, 34-39, 51-56 (issued Jan. 28, 1997) (emphasis in italics added).

The parties dispute the construction of claim 1 (and in particular its preamble) and the terms "tab," and "lip" in claims 1, 3, and 6. Both parties agree that what is unusual about this case is that the patent holder-UTC-is not trying to broaden its patent claims to encompass brush seals or configurations different from the one

UTC designed. Rather, it is seeking (at least for some claims) to rather narrowly describe essentially only the brush seal that UTC designed, which UTC claims PerkinElmer copied through reverse engineering. On the other hand, the alleged infringer-PerkinElmer-seeks an expansive reading of the disputed patent language to encompass much more than a brush seal and configurations far different from UTC's design, presumably in order to enhance PerkinElmer's infringement and invalidity arguments. Therefore, the position of the parties on the scope of the patent is essentially the reverse of what one would expect to see in the usual case.

A. Claim 1 and its Preamble

Certainly the first, and in many ways the primary, construction issue in this case is that of claim 1 and its preamble, which starts at the beginning of claim 1 and ends just before the words "the brush seal including." '167 Patent at 6:5-13. Though preambles are more commonly not limiting, they may be limiting where the entire patent so instructs. *See* Bicon, 441 F.3d at 952. In this case, the Court's task is not to ascertain whether claim 1's preamble is limiting; both parties agree that it is. *See* UTC's Claim Br. at 15; Defs.' Claim Br. at 14. Instead, the issue is *how* the preamble limits claim 1. In brief, the question this Court must answer is whether, as UTC argues, claim 1 describes a stand-alone brush seal that operates in a particular design envelope described in the preamble, or whether, as PerkinElmer contends, the preamble recites structural features of the invention—a brush seal and a stationary carrier, a retaining means, an annular spacing, and first and second cavities—that limit claim 1 by requiring both a brush seal and a particular housing structure or framework. In other words, according to PerkinElmer, claim 1 describes a "brush seal assembly," and not simply a stand-alone brush seal. This issue is important because both parties agree that PerkinElmer sold only a brush seal and not a brush seal assembly. FN3

FN3. Apparently, UTC sold brush seal assemblies to United Airlines, and the stand-alone brush seals later needed replacement. Finding UTC's replacement brush seals too expensive, United Airlines sought alternative suppliers and approached PerkinElmer to provide the replacement stand-alone brush seals. *See* Defendants' Motion for Summary Judgment of Non-Infringement [doc. # 69], at 1-2.

[11] [12] Whether, and thus how, a preamble is limiting is determined by reviewing the claim as a whole and the entire patent to ascertain whether the preamble recites essential structure, whether the drafter used both the preamble and the body of the claim to define the claim, and whether limitations in the body of the claim rely upon or derive antecedent meaning from the preamble. *See* Bicon, 441 F.3d at 952; *In re Cruciferous*, 301 F.3d at 1347. Having considered this issue at length, the Court believes that a reading both of claim 1 as a whole and of the patent in its entirety shows that claim 1 describes a stand-alone brush seal, albeit one that functions in a design envelope described in the preamble. The Court reaches this conclusion for a number of reasons.

First, the introduction to claim 1's preamble explicitly specifies that what the claim covers is "*a brush seal*." '167 Patent at 6:5 (emphasis added). Indeed, those are the first three words of the claim. The phrase "brush seal assembly," which along with "brush seal" appears elsewhere in the patent, is nowhere to be found in claim 1 or its preamble. *See id.* at 6:57, 61; 7:11, 15, 27, 33.

Second, the language that follows "a brush seal" in the preamble (though perhaps not the epitome of clear claim drafting) does not indicate that anything more than a "brush seal" is claimed. Indeed, the first phrase states "[a] brush seal *for* discouraging fluid flow through an annular spacing," *id.* at 6:5-6 (emphasis added),

indicating that the preamble describes the purpose or function of the brush seal claimed, *see* *Bicon*, 441 F.3d at 952; *C.R. Bard, Inc. v. M3 Sys., Inc.*, 157 F.3d 1340, 1350 (Fed.Cir.1998). The forty words that then follow the phrase "annular spacing" describe the *location* of the annular spacing (between stationary and rotating surfaces) through which the brush seal is designed to discourage fluid flow. *See* '167 Patent at 6:6-9. And the remainder of the preamble describes two structures near the annular spacing-"the carrier including a retaining means"-as "being engageable" with the "brush seal [when] in an installed condition." *Id.* at 6:9-13. Thus, the preamble describes a brush seal that is "engageable" with, or "able to engage," the carrier, including a retaining means, when the brush seal is in an installed condition. *See* *Pfizer Inc. v. Ajix, Inc.*, CIV3-03CV754 (JCH), 2005 WL 1828830, at (D.Conn. July 29, 2005) ("The term 'engageable,' [is] commonly understood to mean 'able to engage....' "). The combination of these features-use of the term "brush seal," the descriptions of purpose and location, and the conditional language "engageable"-all indicate that the preamble is intended to describe a design envelope in which the claimed brush seal operates, so that when placed in this design envelope, the brush seal achieves the patent's goals of foolproofing and anti-rotation.

This conclusion is further buttressed by the body of claim 1, which reiterates that what is being claimed is a "brush seal." Thus, the body of the claim describes the invention as including at least one brush stage, a backing plate, a sideplate, and a tab, but notably, not any housing structure or framework. *See* '167 Patent at 6:13-29. The body of the claim thus describes the tab as affixed to the "brush stage" and as "engaging" the "retaining means" (described in the preamble as "being engageable with the brush seal," *id.* at 6:11), "to block rotation" and to interface with the carrier, when the brush seal is installed, *see id.* at 6:21-29.

PerkinElmer contends that this language-specifically the reference to "engaging" the retaining means-demonstrates that claim 1 relates to a seal *and* its housing structure, noting that the body of the claim does not use conditional language such as "capable of engaging." Yet, as PerkinElmer itself points out, the language of the body of the claim should be read in light of the meaning accorded those terms in the preamble. *See* Defs.' Claim Br. at 18 ("Because, 'retaining means' is first defined in the preamble, the preamble must be consulted to understand the meaning of [the] phrase."); *Bicon*, 441 F.3d at 952. Given that the Court finds that the preamble refers to a design envelope in which a stand-alone brush seal operates, any terms later repeated should be read in light of how those terms are understood in the preamble. FN4 This means that if the preamble defines the tab as "being engageable with the retaining means," then the reference in the body of claim 1 to "the retaining means" would mean the retaining means discussed in the preamble-namely, one that is able to engage with the tab on the stand-alone brush seal. FN5

FN4. The same analysis would apply to PerkinElmer's contention that language in claim 3 demonstrates that claim 1 describes a seal and its housing structure. The relevant language in claim 3 reads as follows: "wherein the retaining means is vane assembly sideplate, the vane assembly sideplate being fastened to an adjacent vane assembly and extending over the brush seal, wherein the tab is disposed on the side of the brush seal facing the second cavity." '167 Patent at 6:34-39. PerkinElmer points out that this language is definite and not conditional; the language says "extending over the brush seal," not "able to extend over a brush seal." However, for the reasons stated in the text, the Court concludes that this language should be read in the light of the preamble and as such, it refers to the design envelope in which a stand-alone brush seal operates, and not a brush seal assembly.

FN5. It is also worth noting the distinctions between this case and *Cross Medical Products, Inc. v. Medtronic Sofamor Danek, Inc.*, 424 F.3d 1293 (Fed.Cir.2005), the case that PerkinElmer cites to buttress

its argument that phrases such as "engaging the retaining means" and "extending over the brush seal" should not be construed in the conditional sense of "able to engage" or "able to extend." Cross Medical did not include preamble language similar to that in claim 1 that would give meaning to terms that are repeated in the body of the claim. *See id.* at 1306.

Furthermore, the language of the entire patent points to the same conclusion. Claims 3 and 6 each begin with the words "The *brush seal* according to claim 1" and "claim 3." *See* '167 Patent at 6:34, 51 (emphasis in italics added). Moreover, claim 7—one of the three independent claims in the patent—uses similar preamble language, but is different from claim 1 in the following three important respects. Claim 7 claims (1) a "brush seal assembly," (2) omits claim 1's locational description of the "annular spacing," and (2) describes the claimed "brush seal assembly" as "including a stationay [sic: stationary] carrier, a rotating surface proximate to the carrier, at least one brush stage, and a tab disposed in a fixed relationship to the brush stage, the carrier including a retaining means being engageable with the brush stage...." '167 Patent, 6:57-65. FN6 Put simply, claim 7 describes a brush seal and its housing structure, precisely what PerkinElmer argues claim 1 specifies. The '167 Patent's part-then-whole approach—as illustrated in claims 1 (stand-alone brush seal) and 7 (brush seal assemblies)—would make sense to one ordinarily skilled in the art, thus satisfying the patent law's public notice requirement. *See Bicon*, 441 F.3d at 950. Indeed, it would make little sense for UTC to patent the whole—the "brush seal assembly" (claim 7)—and not the critical part—the "brush seal" (claim 1)—given that the stand-alone brush seal is the part that would be in the most frequent need of replacement, and thus most at risk of infringement.

FN6. Though relevant, the doctrine of "claim differentiation" does not play a role in this Court's analysis at this point. At this juncture, the Court's reference to claim 7 is done merely to interpret the preamble in light of the entirety of the patent. *See, e.g., Bicon*, 441 F.3d at 952 (stating that preambles should be read in light of the patent as a whole); *In re Cruciferous*, 301 F.3d at 1347 (same).

The specification also supports the Court's conclusion that claim 1 describes a stand-alone brush seal, while claim 7 describes a brush seal assembly. For example, the introduction to the specification provides that "[t]he *present invention* relates to *brush seals*." '167 Patent at 1:6-7 (emphasis added). There would be little point to such a statement if none of the claims related to brush seals and all of the claims described various brush seal assemblies. FN7 Furthermore, the background section goes on to discuss the function or purpose of "brush seals" and the wear and tear that results from reverse installation and rotation. *See id.* at 1:16-45. It then states that the applicant is "working to develop improved brush seals." *Id.* at 2:2-3. And the "principle feature of the present invention" is described as "the tab extending outward from the *brush seal*." *Id.* at 2:40-41 (emphasis added); *see also id.* at 2:57-59 ("A further advantage of the present invention is the increased durability of the *brush seal* as a result of the elimination of machining of the *brush seal*") (emphasis added).

FN7. Even though patent titles are "near[ly] irrelevant to] claim construction," *Pitney Bowes, Inc. v. Hewlett-Packard Co.*, 182 F.3d 1298, 1312 (Fed.Cir.1999), it is also worthwhile to note that the title of the patent provides for a "*Brush Seal With Fool-Proofing and Anti-Rotation Tab*," '167 Patent at [54], 1:1-2 (emphasis added).

The embodiments of the invention also support the Court's interpretation. *See Phillips*, 415 F.3d at 1323

(stating that the specification should be used to interpret claims and not to import limitations from the preferred embodiments); *Phonometrics, Inc. v. N. Telecom, Inc.*, 133 F.3d 1459, 1466 (Fed.Cir.1998) ("Although claims are not necessarily restricted in scope to what is shown in a preferred embodiment, neither are the specifics of the preferred embodiment irrelevant to the correct meaning of claim limitations."). The section of the specification entitled "Brief Description of the Drawings" notes that Figures 3, 4, 5, and 6 describe "brush seals," *see* '167 Patent at 3:7-14, and the "Best Mode" section refers to the inner and outer "brush seal assemblies" as including a stationary carrier, a brush seal, and a retainer, *see id.* at 3:63-65; 4:33-35. In addition, the inventors repeatedly distinguished between a stand-alone "brush seal," and a "brush seal assembly," where they contemplated the entire structure. *See id.* at 4:33-35 ("The outer brush seal assembly **44** includes ... a brush seal **96**...."), 5:44-47 ("For the outer brush seal assembly **44**, the brush seal **96**"), fig. 5 (noting brush seal within outer brush assembly); *id.* at 3:64-65 ("The inner brush seal assembly **42** includes ... a brush seal **62**...."); 5:28-29 ("For the inner brush seal assembly **42**, the brush seal **62**"); fig. 3 (noting brush seal within inner brush assembly). Thus, the embodiments point to the stationary carrier, brush seal, and a retainer when discussing the assembly, but just to the seal when discussing a stand-alone brush seal.

PerkinElmer points to the abstract, the first sentence of which begins "[a] brush seal assembly," and argues that this indicates that the patent as a whole claims only a brush seal assembly and not component parts—that is, a stand-alone brush seal. The abstract does form a part of the specification. *See Pandrol USA, LP v. Airboss Ry. Prods., Inc.*, 320 F.3d 1354, 1363 n. 1 (Fed.Cir.2003). *But see C.R. Bard, Inc. v. U.S. Surgical Corp.*, 388 F.3d 858, 864 (Fed.Cir.2004) ("[A] statement's location[, such as in the abstract,] is not 'determinative'...."). However, the Court does not find the abstract as clear as PerkinElmer supposes it to be. For instance, as highlighted in italics in the footnote accompanying this text, FN8 the abstract refers to the tab as attached to the "brush seal assembly," and also describes the "brush seal assembly" as including a tab that is engageable with a "brush seal retainer." Given that the brush seal assembly, as described by claim 7 (and PerkinElmer), includes at least a brush seal, a retaining means, and a carrier, the abstract provides no clear indication of what component the tab is attached to, except insofar as to suggest that the "brush seal retainer" is excluded. The abstract also describes the "brush seal assembly" as being installed within a carrier. Yet it is apparent that the "brush seal assembly" *includes* the carrier within which the brush seal must be installed. Further, the abstract does not exclude the possibility of a patent on both a brush seal and a brush seal assembly.

FN8. The '167 Patent's abstract states: " *A brush seal assembly includes a tab extending outward and engageable with a brush seal retainer. Various construction details are disclosed that provide a tab that prevents rotation of the brush seal during use and also prevents reverse installation of the brush seal assembly. In a particular embodiment, a brush seal assembly for installation within a carrier includes a tab that fits radially within a cut-out in a retaining means. Engagement with the cut-out prevents rotation. The tab extends outward from the low pressured side of the brush seal assembly. If installed in a reverse orientation, the tab engages the carrier to block installation of the retaining means.*" '167 Patent at [57] (emphasis added).

At best, therefore, the abstract is ambiguous. As a consequence, the Court must look to the rest of the specification for assistance, and the balance of the specification provides sufficient basis on which to conclude that claim 1, at least, describes only a stand-alone brush seal, and not the entire brush seal assembly. In sum, in light of the way the preamble itself is worded, the wording of the body of claims 1 and 7, and the evidence provided in the specification, the Court concludes that a person ordinarily skilled in the

art would read the preamble as describing the design envelope into which the claimed brush seal fits.

Applying the doctrine of "claim differentiation" only strengthens the Court's conclusion. This doctrine "is based on the common sense notion that different words or phrases used in separate claims are presumed to indicate that the claims have different meanings and scope." Andersen, 474 F.3d at 1369 (quotation marks omitted). "[This] tool works best in the relationship between independent and dependent claims," Curtiss-Wright, 438 F.3d at 1380, but it also applies to two independent claims, *see id.* Two considerations generally govern the analysis: "(1) claim differentiation takes on relevance in the context of a claim construction that would render additional, or different, language in another independent claim superfluous; and (2) claim differentiation can not broaden claims beyond their correct scope." *Id.* at 1381 (quotation marks omitted). In view of the differences in phrasing between claim 1 and claim 7, the claim differentiation doctrine supports the Court's view that claim 1 should not be read to encompass an entire brush seal assembly, as such an interpretation would render claim 7—which all agree describes brush seal assemblies—superfluous.FN9

FN9. The same reasoning applies to claims 3 and 6, which are identical to claims 9 and 12 except that claims 3 and 6 refer to "brush seals," while claims 9 and 12 refer to "brush seal assemblies," and all refer to the differing claim numbers on which they are dependent. Thus, construing claims 3 and 6 as referring to brush seal assemblies would render claims 9 and 12 superfluous. *See* Curtiss-Wright, 438 F.3d at 1381.

PerkinElmer argues that the claim differentiation doctrine does not support UTC because there are differences between claim 1 and claim 7 that would not render them redundant or superfluous if interpreted in the manner PerkinElmer suggests. The crux of PerkinElmer's argument appears to be that claim 1, and thus its dependent claims, would still be different from claim 7, and its dependent claims, because in claims 1, 3, and 6, the retaining means and tab engage with a *brush seal*, while in claims 7, 9, and 12, they engage with a *brush stage*.FN10 *See* Defs.' Claim Construction Reply Br. ("Defs.' Claim Reply Br.") [doc. # 85], at 6-7. Perhaps recognizing the tenuous nature of this argument, PerkinElmer devotes only a brief footnote to explaining how a brush seal is different from a brush stage. The footnote states as follows: "The terms 'brush stage' and 'brush seal' are not coextensive. As claim 1 indicates, a 'brush seal' may include a number of 'brush stages,' each of which has a brush array, a backing plate, and a side plate." *Id.* at 6 (quoting '167 Patent at 6:13-20).

FN10. Without explaining, PerkinElmer asserts that the omission of the locational language regarding "annular spacing" in claim 7 also differentiates the claims. *See* Defs.' Claim Reply Br. at 6. The Court agrees, but for different reasons than PerkinElmer might propose: claim 1's preamble language, including the locational language, describes the brush seal's design envelope into which the claimed stand-alone brush seal sits, while claim 7 describes the brush seal assembly.

PerkinElmer's attempt to differentiate claims 1 and 7 is unpersuasive. Claim 1 describes a "brush seal" as including at least one "brush stage" with an affixed tab. *See* '167 Patent at 6:21. Thus, references to a "stage" in claim 7 are almost interchangeable with references to a "seal" in claim 1. Indeed, aside from noting that "brush stage" and "brush seal" are not co-extensive, PerkinElmer does not explain how the difference in the use of those terms would be applied to give claim 7 meaning if claim 1 were construed as a brush seal assembly. Likewise, the Court can think of none. Of course, the doctrine of claim differentiation only creates a presumption, which can be overcome. *See* Andersen, 474 F.3d at 1370. However, nothing in the intrinsic evidence indicates that the presumption should be overcome in this case. *Cf. id.* (refusing to

apply claim differentiation, but where intrinsic record offered a different result and claims were not otherwise identical and thus construction would not render other claims redundant); *Multiform Desiccants, Inc. v. Medzam, Ltd.*, 133 F.3d 1473, 1480 (Fed.Cir.1998) ("[T]he doctrine of claim differentiation can not broaden claims beyond their correct scope, determined in light of the specification and the prosecution history and any relevant extrinsic evidence.").

Next, in a somewhat different twist on claim differentiation, PerkinElmer argues that UTC's interpretation of claim 1 would render claim 3 invalid because claim 3 (which is a dependent claim) "adds to claim 1 only by specifying the nature of the 'retaining means' ... and the cavity towards which the tab faces...." Defs.' Claim Br. at 22. Therefore, PerkinElmer notes, if claim 1 does not require a retaining means or a second cavity, claim 3 would be invalid because it would add features that are not claim limitations and thus would not limit the scope of claim 1, as required by law. *See* 35 U.S.C. s. 112, para. 4 ("[A] claim in dependent form shall contain a reference to a claim previously set forth and then specify a further limitation of the subject matter claimed.").

However, as already explained, claim 1 does provide for a limitation, just not the limitation PerkinElmer would prefer. Claim 1 describes the design envelope in which the claimed stand-alone brush seal resides. Claim 3 further limits both the brush seal and its design envelope by specifying that the brush seal's tab faces the second cavity, which enables it to fit within the design envelope of a vane assembly sideplate, as described in claim 3. FN11 *See* '167 Patent at 6:35-39. As further confirmation of this construction, it is apparent that PerkinElmer's approach would render claim 9 superfluous. For, as noted, claim 9 is identical to claim 3, except that claim 3 refers to a "brush seal" while claim 9 refers to a "brush seal assembly" (both also refer to the differing claim numbers on which they are dependent). The Court's construction of claim 3 therefore preserves claim 9's meaning.

FN11. UTC has a separate patent on the vane assembly sideplate. *See* *Brush Seal Support and Vane Assembly Windage Cover*, U.S. Patent No. 5,522,698 (issued June 4, 1996).

Finally, the cases on which PerkinElmer relies are distinguishable. For example, in *In re Cruciferous*, the Federal Circuit found that the preamble term "rich in glucosinolates" acted as a limitation on the body of the claim because *both the specification and prosecution history* indicated that it did so. 301 F.3d at 1347. As already discussed, the '167 Patent's specification does not indicate the limitation that PerkinElmer advocates. Nor does the prosecution history. *See* *infra* at 407-10.

In addition, *Bicon*, on which PerkinElmer also relies, undercuts PerkinElmer's argument. The preamble in *Bicon* recited,

An emergence cuff member for use in preserving the interdental papilla during the procedure of placing an abutment on a root member implanted in the alveolar bone of a patient in which the abutment has a frusto-spherical basal surface portion and a conical surface portion having a selected height extending therefrom comprising....

Bicon, 441 F.3d at 948 (alterations omitted). The patentee made an argument that can be analogized (to a limited extent) to that which UTC makes here-that is, that the claim recited " 'an emergence cuff member,' not a combination consisting of an emergence cuff member and other features, such as an abutment having certain specific characteristics[, and that the preamble] in no way limits the claim because it merely sets

forth the purpose or use of the emergence cuff." Id. at 949-50 (alterations omitted). The district court concluded that the preamble was an integral part of the claim and limited the claim, with one of the limitations being an abutment with a "frusto-spherical basal surface portion." Id. at 949. The Federal Circuit affirmed, finding that "[d]espite the fact that the claim begins with a reference to the emergence cuff alone, the full text of the claim, *read in the context of the entire patent*, indicates that the claimed invention is the combination of the emergence cuff and the abutment, operating together in the fashion recited in the claim and described in the specification." Id. at 952 (emphasis added).

UTC's argument differs from that of the Bicon patentee in that UTC does not contend that claim 1's preamble language "in no way limits the claim." Rather, UTC argues that the preamble language limits the claim, but only by describing the brush seal's design envelope; it proposes that all of the features of that envelope (as specified in claim 1's preamble) describe limitations on the housing structure in which the claimed stand-alone brush seal would fit. Similarly, in Bicon, the Federal Circuit found that the preamble described structural features of the abutment that is used with the emergence cuff. And unlike the claim at issue in Bicon, claim 1's preamble does not recite more structure than is necessary to describe the location of the brush seal in the housing structure. *See id.* at 953.

In many ways, claim 1's preamble is more analogous to the claim preamble in *C.R. Bard, Inc. v. M3 Systems, Inc.*, 157 F.3d 1340 (Fed.Cir.1998), which the Bicon court took care to distinguish. The preamble to C.R. Bard's claim 21 read: "A biopsy needle for use with a tissue sampling device having a housing with a forward end, a first slide mounted for longitudinal motion within said housing, and a second slide mounted for longitudinal motion within said housing, said biopsy needle comprising...." M3 Sys., 157 F.3d at 1348-49. The invention at issue was a "firing device" or "gun" used to mechanically inject a biopsy needle into body tissue. The gun was twice patented, and the plaintiff argued that the second patent covered a gun with various structural features, including an external automatic cocking mechanism. Focusing on the preamble, however, M3 Systems, the defendant, argued that the preamble referred "only to the 'housing' of the tissue sampling device, and that the lack of any preamble reference to an external automatic cocking mechanism invalidate[d] the claims by anticipation because they fail [ed] to distinguish the gun of the preamble from the prior art first generation gun." Id. at 1350. The Federal Circuit rejected M3 Systems' argument and ruled for the plaintiff, stating,

[T]he preamble of claim 21 recites the portion and structure of the gun housing into which the needles fit, and *provides reference points* in the gun that aid in defining the needles as set forth in the body of the claim. M3 Systems is incorrect in stating that the preamble must contain details of the integrated mechanical cocking structure, for the gun structure is not part of the separate claims to the needles.

Id. (emphasis added).

Thus, M3 Systems concluded that the fact that the preamble mentioned the portion of the gun housing into which the needles fit did not mean that the gun structure was part of the claim; the preamble limited the claim only to the extent to which it described the location in which the needle fit. This Court's construction of claim 1 adopts a similar approach, in that it concludes that the fact that claim 1's preamble mentions the type of housing into which the claimed stand-alone brush seal fits, does not mean that the housing structure became a part of claim 1.

PerkinElmer makes one final argument for limiting claim 1 to a brush seal assembly. Pointing to *In re Cruciferous*, which states that "[c]lear reliance on the preamble during prosecution to distinguish the claimed

invention from the prior art may indicate that the preamble is a claim limitation because the preamble is used to define the claimed invention," 301 F.3d at 1347, PerkinElmer contends that during prosecution, UTC relied on the structural limitations recited in claim 1's preamble in distinguishing the '167 Patent from prior art, and thus the claim should be so limited. How PerkinElmer reaches this conclusion escapes the Court.

In this case, the Patent Examiner initially rejected claims 1-18 on three bases: first, under 35 U.S.C. s. 112, para. 2 as being *indefinite*; second, under 35 U.S.C. s. 102(b) as being *anticipated* by prior art (an already patented brush seal titled the "Flower brush seal"); and third, under 35 U.S.C. s. 103 as being *obvious* "over Hanrahan in view of Pope," two prior art brush seals. *See* Defs.' Claim Br., Ex. L ("Prosecution History"), Tab 1. In making the indefiniteness objection, the Examiner stated that the phrase "to thereby prevent fixed retention" appearing in independent claims 1, 7, and 13 seemed to be "incorrect." *See id.* at 2. UTC responded to this objection by stating that the phrase

refers to the result obtained when assembling the *brush seal* of the present invention with the carrier therefor backwards, such that *the tab on the brush seal fails to properly engage the carrier*. As set forth in the specification, such improper assembly results in retainer 64 not aligning correctly with carrier 58 whereby rivet 72 is unable to align with the apertures in those members to fixedly retain the brush seal to the carrier. The phrase questioned by the Examiner *states that result* and is therefore incorrect.

Id., Tab 2 at 1-2 (emphasis added).

As to the anticipation objection, the Examiner stated that "Flower discloses a seal as claimed. The various embodiments disclose a sideplate 36 having a tab as claimed. Since this tab has the structure as claimed, it will inherently function as claimed, to a certain extent." *Id.*, Tab 1 at 2. UTC responded by stating,

"The Flower Patent is merely an example of the prior art set forth in the background of the instant application and is significantly different from the claimed invention herein. Unlike *Applicants' tabbed brush seal*, Flower discloses a hooked edge or tongue with [sic: which] engages a continuous groove formed in a face of the brush seal. As set forth in Applicants' specification (pages 4 and 5), providing such groove or recess *requires machining* of the brush seal thereby, adversely affecting the durability thereof and adding substantially to the manufacturing cost of the seal. *Unlike the Flower brush seal, in Applicants' claimed brush seal, tabs attached to the brush seal engage the retaining means* thereby obviating any machining processes on the brush seal, which would otherwise contribute to the cost thereof and adversely affect the seal's durability."

Id., Tab 2 at 2 (emphasis in italics and underlining added).

The Examiner's obviousness objection noted that "Hanrahan discloses a *seal* substantially as claimed. The *seal* includes a tab/lip 22. In Hanrahan, the tab/lip is fixed to the *carrier instead of the seal*. Pope, however, discloses that an anti-rotation tab/lip may be fixed to either the *seal* or carrier." *Id.*, Tab 1 at 3 (emphasis added). The Examiner went on to note, "Therefore, it would have been obvious to modify Hanrahan by fixing the tab/lip to the *seal* The prior art of Mierley, Short and GB 819,288 disclose *seals* having features in common with the instant invention." *Id.* (emphasis added). UTC responded as follows:

"Element 22 in Hanrahan is *not a tab/lip* as the Examiner states, *but rather a pin* provided in the seal carrier, which engages a hole provided in the brush seal. Such a hole, like a groove, *requires machining and therefore weakens the brush seal and adds to the manufacturing cost thereof*. The tabs provided on

Applicants' *brush seal do not require any machining* and therefore, do not detract from the seal's durability or add significantly to manufacturing costs.... Pope is not even concerned with a brush seal but rather with prior art knife edge seals.... No antirotation function is mentioned. The pins are not fixed to the seal as are Applicants' tabs but rather, are loosely accommodated in grooves therein. Furthermore ... they do not function to prevent the reverse installation thereof as do the tabs claimed by Applicants.... None of the prior art references taken individually or in concert *disclose Applicants' unique, economical and durable brush seal structure* wherein tabs fixed to the seal are received within recesses in the seal carrier...."

Id., Tab 2 at 3-4 (emphasis in italics added, underlining in original).

Based on the foregoing exchange, PerkinElmer contends that the *In re Cruciferous* standard is met. Specifically, PerkinElmer argues that the underlined portion of the above response relating to the Flower brush seal indicates a reliance on a housing structure and that UTC did not argue that any of its claims were limited to the brush seal alone.

Once again, the Court does not find PerkinElmer's arguments persuasive. *In re Cruciferous* presents a very different scenario from this case. As noted, the question in *In re Cruciferous* was whether the preamble term "rich in glucosinolates" acted as a limitation on the body of the claim. There, during prosecution, the patentee argued that Claim 1 of the patent was directed to

[a] method of preparing a food product rich in glucosinolates, ... and harvesting sprouts prior to the 2-leaf stage, to form a food product comprising a plurality of sprouts.... Although "rich in glucosinolates" is recited in the preamble of the claim, the pertinent case law holds that the preamble is given weight if it breathes life and meaning into the claim.... Accordingly, the cited prior art does not anticipate the claims because it does not explicitly teach a method of preparing a food product comprising cruciferous sprouts that are rich in glucosinolates or contain high levels of Phase 2 inducer activity.

In re Cruciferous, 301 F.3d at 1347-48 (quotation marks omitted and alterations in original).

Here, the ' 167 Patent's prosecution history does not reveal "clear reliance" (if any at all) even approaching that demonstrated in *In re Cruciferous*. UTC's responses to the Examiner's objections focused on the brush seal itself, emphasizing that the major improvement over the prior art brush seals, Flower and Hanrahan, was the avoidance of machining (a manufacturing process that involves the cutting of metal with a tool), by attaching the tab to the brush seal using a method other than machining, and by using a tab, rather than a pin, that would need a machined receptacle to properly function. UTC's responses emphasized the problems with machining-weakened durability of the seal and increased manufacturing costs. These responses did not emphasize or rely on the housing structure as a distinguishing factor from the brush seal itself. Indeed, in view of the fact that the Examiner constantly referred to the "brush seal" without referencing the housing structure, and posed questions relating to the tab/lip on the brush seal, it was unnecessary for UTC to clarify that its claims were limited to the brush seal alone. This is so especially given that, as discussed above, claim 1 sought to claim a stand-alone brush seal, while claim 7 sought to claim the brush seal assembly.

In the end, perhaps PerkinElmer's best argument is a commonsense one—that a stand-alone brush seal itself does not prevent rotation or foolproofing; it is only the combination of a brush seal and a retaining means that achieves the goals of the patent. Therefore, PerkinElmer argues, claim 1 must describe a brush seal assembly and not simply a brush seal. PerkinElmer's premise is correct, but its conclusion is not. For there is nothing to prevent UTC from seeking to patent both the standalone brush seal itself—which UTC claims has

certain unique features-and the entire brush seal assembly. Upon examination of the claims, specification, and prosecution history, the Court is of the view that the ' 167 Patent did just that. For claim 1 describes a stand-alone brush seal while claim 7 describes a brush seal assembly. And since both claim 3 and 6 are dependent on claim 1, it follows that these claims, too, describe stand-alone brush seals.

B. "Tab" and "Lip"

Having concluded that claim 1 relates to a stand-alone brush seal, the Court now turns to construction of the terms "tab" and "lip," as those words appear in claims 1, 3, and 6.

1. Tab

At this point, the parties dispute two aspects of the term "tab": (1) how it is attached to the brush seal-that is, whether it requires machining; and (2) its position or location in relation to the retaining means-that is, whether it is "radially offset." Initially, the parties also disputed the shape of the "tab." PerkinElmer argued that the "tab" can have any shape. *See* Defs.' Claim Br. at 25-30. During briefing, UTC countered that the word "tab" should be construed as a "flat, rectangular" shaped projection. *See* UTC's Claim Br. at 23. However, at oral argument, UTC abandoned its proposed construction and acknowledged that the word "tab" could encompass any shaped projection, which would include, but not be limited to, a "flat, rectangular" shape. *See* Markman Hearing Transcript, August 17, 2007 (" Markman Hr'g Tr.") at 85:15-21, 94:23-24, 103:7-25 to 104:1-3. Because of UTC's concession, the shape of the term "tab" is no longer at issue and the Court will therefore adopt PerkinElmer's construction of that term as it relates to the shape of the tab-namely, "an appendage, projection or extension of a brush seal," *see* Defs.' Claim Br. at 23, that is "not limited to flat or rectangular structures with L-shaped cross-sections," *id.* at 25.

Although the Court first discusses the features attributed to the word "tab" as used in claim 1, these issues are also relevant to the dependent claims 3 and 6, since the term "tab" appears in all three claims and should have the same meaning in all three claims, except where there is modifying language. *See* Wilson Sporting Goods Co. v. Hillerich & Bradsby Co., 442 F.3d 1322, 1328 (Fed.Cir.2006) ("[T]he same terms appearing in different claims in the same patent ... should have the same meaning unless it is clear from the specification and prosecution history that the terms have different meanings at different portions of the claims." (quotation marks omitted)).

[13] Though admittedly, as PerkinElmer points out, one would not necessarily know this from the language of the claim itself, the tab described in claim 1 (and thus claims 3 and 6) is one that is not machined. Although claim 1 is silent on this matter, providing only that the tab is "disposed in a fixed relationship to the brush stage," ' 167 Patent at 6:21, the specification repeatedly states that the tab is not machined. Significantly, the "Disclosure of the Invention" section of the specification begins: "The *present invention* is predicated in part upon the recognition that machining the brush seal after fabrication weakens the weld bond between the brush stages and between the backing plates and sideplates." *Id.* at 2:6-9 (emphasis added). The reference to "present invention" in this statement is noteworthy because "[s]tatements that describe the *invention as a whole* ... are more likely to ... support a limiting definition of a claim term...." U.S. Surgical, 388 F.3d at 864 (emphasis added); *accord* Andersen, 474 F.3d at 1367-68 (describing similarly-phrased sentences as "characterizations directed to the invention as a whole"); *SciMed Life Sys., Inc. v. Advanced Cardiovascular Sys., Inc.*, 242 F.3d 1337, 1343 (Fed.Cir.2001) ("[T]he characterization of the coaxial configuration as part of the 'present invention' is strong evidence that the claims should not be read to encompass the opposite structure."). The Disclosure continues to describe non-machining as characteristic of the "present invention," while explaining that the '167 Patent seeks to avoid the problems

associated with machining, stating that "[a] further advantage of the present invention is the increased durability of the brush seal as a result of the elimination of machining," '167 Patent at 2:57-59, and that "the present invention does not require machining of a recess or groove into the support structure," *id.* at 2:60-62.

Therefore, the specification makes abundantly clear that the '167 Patent seeks to avoid the disadvantages associated with machining and "it would be peculiar for the claims to cover prior art that suffers from precisely the same problems that the specification focuses on solving." *LizardTech, Inc. v. Earth Res. Mapping, Inc.*, 424 F.3d 1336, 1343-44 (Fed.Cir.2005) (citing *Phillips*, 415 F.3d at 1327).FN12 While "courts cannot rewrite claims [,] in clarifying the meaning of claim terms, courts are free to use words that do not appear in the claim so long as the resulting claim interpretation accords with the words chosen by the patentee to stake out the boundary of the claimed property." *Pause Tech., LLC v. TiVo, Inc.*, 419 F.3d 1326, 1333 (Fed.Cir.2005) (quotations marks and alterations omitted). Therefore, even though the claims do not assert non-machining as a feature of the "tab," the specification repeatedly emphasizes that non-machining is integral to the invention, thus giving due notice to one ordinarily skilled in the art.

FN12. The "Best Mode" section of the specification refers to the "tab" as being tack-welded—that is, not machined—in Figures 3 and 5. *See* 4:24-25 (discussing Figure 3 and stating that "The tab 84 is tack welded"); 4:61-62 (discussing Figure 5 and stating that "The tab 116 is tack welded....").

The prosecution history also supports this reading of the specification. As previously discussed, UTC's response to the Examiner's objections distinguished the Flower and Hanrahan brush seals by emphasizing that the UTC invention avoids machining the seal:

Element 22 in Hanrahan is not a tab/lip as the Examiner states, but rather *a pin* provided in the seal carrier, which engages a hole provided in the brush seal. Such a hole, like a groove, *requires machining and therefore weakens the brush seal and adds to the manufacturing cost thereof*. The tabs provided on Applicants' brush seal *do not require any machining and therefore, do not detract from the seal's durability or add significantly to manufacturing costs*.

See Prosecution History, Tab 2 at 2-4 (emphasis in italics added). Accordingly, the Court construes the term "tab" as described in claim 1 (and thus claims 3 and 6) as one that is not machined.

In the end, PerkinElmer argues for the ordinary or dictionary meaning of the word "tab," which is certainly not restricted to one that requires no machining. But as the Federal Circuit recognized in *Phillips*, the dictionary or ordinary meaning of terms is not always a reliable guide to what the patentee intended. As that court noted, "The problem is that if the district court starts with the broad dictionary definition in every case and fails to appreciate how the specification implicitly limits that definition, the error will systematically cause the construction of the claim to be unduly expansive." *Phillips*, 415 F.3d at 1321. The court went on to explain that the "risk of systematic overbreadth is greatly reduced if the court instead focuses at the outset on how the patentee used the claim term in the claims, specification, and prosecution history, rather than starting with a broad definition and whittling it down." *Id.* That is what the Court has sought to do in concluding that the words of claim 1 require a non-machined "tab."

The more difficult issue regarding the construction of the term "tab" relates to its position or its location—namely, whether it must be radially offset from the brush seal (that is, extending beyond the edge of the

brush seal). According to UTC, and PerkinElmer appears to agree, the tab described in claim 1 is not necessarily offset—that is, it could or could not be radially offset from the brush seal. FN13 And indeed some of the diagrams provided in the patent show an offset tab (figures 5 and 6) (*see* tab 116, lip 118, and brush seal 96), while others show a tab that is not offset (figures 3 and 4) (*see* tab 84, lip 88, and brush seal 62).

FN13. Language in claim 1 suggested to the Court that the tab described in that claim might be offset. For example, claim 1 describes the tab as "extending outward from the brush seal, the tab being located such that if the brush seal is installed ... the tab interfaces with the carrier to thereby prevent fixed retention of the brush seal to the carrier by the retaining means." ' 167 Patent at 6:24-29. Further, the Disclosure of the Invention section of the specification reiterates that a "principle feature of the present invention is the tab extending outward from the brush seal." *Id.* at 2:40-41. It goes on to state that this extending tab is "radially located such that if the brush seal were installed backwards ... the tab interferes with the carrier." *Id.* at 2:50-54. However, in a supplemental telephonic argument on March 7, 2008, UTC represented to the Court, and PerkinElmer agreed, that those words do not necessarily describe an offset tab. *See also* Markman Hr'g Tr. at 53:14-20 (UTC agrees that figure 3 is not offset).

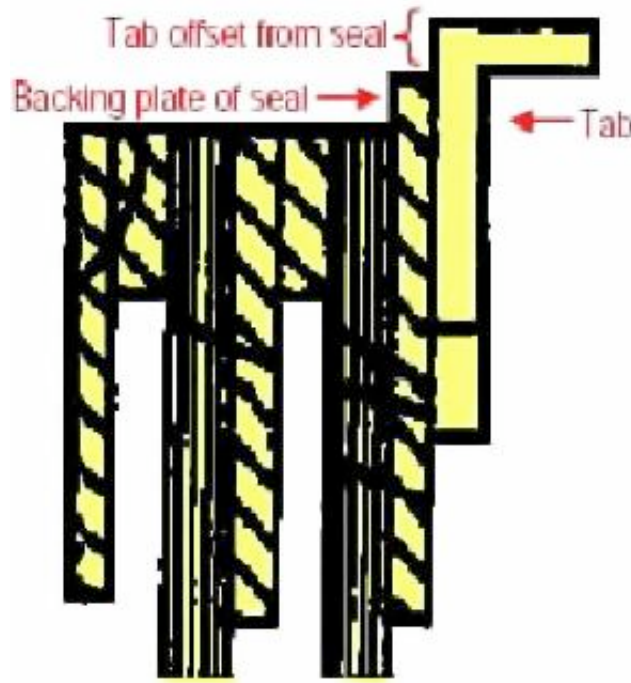

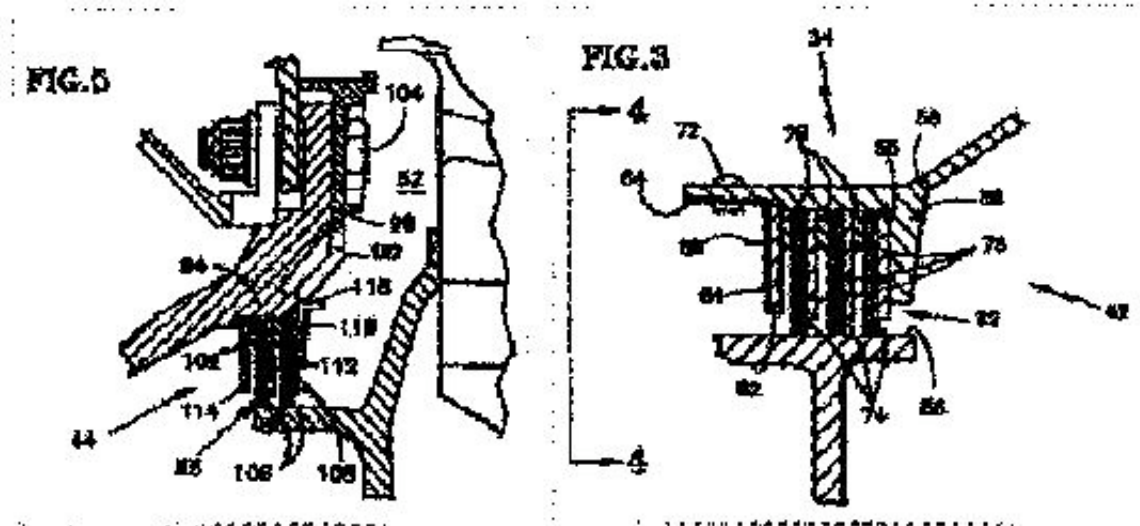

FIG. 5 and FIG. 3

However, as UTC reads the '167 patent, the tab described in claims 3 and 6 must be radially offset. UTC says this is so because of the presence of other language in those claims that is not in claim 1 and that UTC reads as modifying the word "tab" so as to render it offset in claims 3 and 6. *See NTP, Inc. v. Research in Motion, Ltd.*, 418 F.3d 1282, 1310 (Fed.Cir.2005) ("[T]here must be a textual reference in the actual language of the claim with which to associate a proffered claim construction." (quotation marks omitted)). The language in claims 3 and 6 on which UTC relies is that which describes the retaining means as a "vane assembly sideplate, ... wherein the tab is disposed on the side of the brush seal facing the second cavity." '167 Patent at 6:35, 37-39, 51, 53. UTC asserts that whenever a tab is depicted in the patent in connection with a vane assembly sideplate—either in the description provided in the specification or in the diagrams—the tab is radially offset from the brush seal. The depictions providing for a radially offset tab are figures 5 (pictured above) and 6; the written description states that the tab must "extend[] radially outward to a radius **R3** outward of the mean radius **R4** of the vane cover plate **98** and also outward of the radius **R5** of the carrier **94**." '167 Patent at 4:63-65 (emphasis in italics added).

PerkinElmer disputes UTC's construction, arguing that the words of the claim itself do not indicate that the tab is offset and that the " *positioning* of the tab has nothing to do with the meaning of the word 'tab.' " Defs.' Claim Br. at 31. PerkinElmer also sensibly notes that it would have been quite easy for UTC to have inserted the words "radially offset" or "offset" in claims 3 and 6, but UTC did not do so. In fact, PerkinElmer points out, UTC never used those words in describing the tab either during the prosecution history or in the specification outside of the "Best Mode" section. If, PerkinElmer argues, having a radially offset tab was so critical to the invention (and UTC suggests that it is important to the purpose of achieving foolproofing at least in claims 3 and 6, *see* UTC's Claim Br. at 34), then surely UTC would have mentioned that somewhere in the claim, or in the specification (outside of the "Best Mode" section) or during the prosecution history. That UTC did not do so shows that it did not intend to limit its patent in the fashion that it now asserts. Further, PerkinElmer adds, to adopt UTC's approach would be to read the preferred embodiment into the claim language, contrary to Federal Circuit precedent.

[14] Both parties' arguments have merit. On one hand, "[a]n independent claim impliedly embraces more subject matter than its narrower dependent claim." *Intamin Ltd. v. Magnetar Techs., Corp.*, 483 F.3d 1328,

1335 (Fed.Cir.2007). Therefore, it would make sense that claims 3 and 6 would provide for a narrower claim than set forth in claim 1. Further, figures 5 and 6, which the parties agree are directed at claim 3, *see* UTC's Claim Br. at 34, UTC's Claim Construction Reply Brief ("UTC's Claim Reply Br.") [doc. # 67] at 7, Defs.' Claim Reply Br. at 10-11, clearly show a radially-offset tab and describe it as such in those sections of the specification describing these preferred embodiments. In addition, figures 5 and 6 represent the brush seal that UTC developed, which has a radially offset tab. It would seem odd if UTC filed a patent and did not even seek to patent in the most narrow, dependent claim (claim 6), the brush seal that it had developed. *See* Vitronics Corp., 90 F.3d at 1583 (stating that claims will usually encompass the preferred embodiments).

On the other hand, as PerkinElmer properly emphasizes, to accept UTC's argument is to add a feature to claims 3 and 6 that is not discussed explicitly in those claims, or in the specification (outside the "Best Mode" section), or during the prosecution history. PerkinElmer contends that UTC overreached in drafting its patent and sought to encompass as many configurations as possible. According to PerkinElmer, UTC continued with this overly broad approach in the way in which it phrased claims 3 and 6.

[15] This is a very close question. Nevertheless, the Court is more persuaded by PerkinElmer's arguments and concludes that the "tab" in claims 3 and 6 is not limited to a radially offset tab, though the Court hastens to add that the tab in claims 3 and 6 could well be radially offset, or not. Several factors push the Court in this direction. First, "claim terms are normally used consistently throughout the patent, [and] the usage of a term in one claim can often illuminate the meaning of the same term in other claims." Phillips, 415 F.3d at 1314. This suggests, and indeed UTC recognizes, that the word "tab" in claim 1 should have the same meaning—that is, it can either be offset or not—throughout the claim unless there is evidence to indicate otherwise. *See* Wilson, 442 F.3d at 1328 ("[T]he same terms appearing in different claims in the same patent ... should have the same meaning unless it is clear from the specification and prosecution history that the terms have different meanings at different portions of the claims." (quotation marks omitted)). The only evidence that UTC can point to for a different interpretation in claims 3 and 6 are the depictions of figures 5 and 6, and the references in claims 3 and 6 to a vane assembly sideplate as a retaining means and to a tab facing the second cavity. UTC reads these references as providing for an offset tab "because that is how the tab prevents reverse installation when a vane assembly sideplate is the retaining means." UTC's Claim Reply Br. at 8; *see also* UTC's Claim Br. at 34.

As PerkinElmer notes, however, the presence of a vane assembly sideplate and tab facing the second cavity in claims 3 and 6 does not necessarily indicate that those claims provide for a tab that must always be offset. As an initial matter, it is not entirely clear that claims 3 and 6 achieve both advantages of the invention. *See* LizardTech., 424 F.3d at 1343-44 (citing Phillips, 415 F.3d at 1327) ("not every advantage of the invention must appear in every claim"). However, even assuming they do, as best the Court can understand the '167 Patent, a non-offset tab can achieve some degree of foolproofing even when paired with a vane assembly sideplate. This might occur where, as in figure 3, the carrier is designed to include a shoulder, against which the tab would hit if improperly installed. *See* '167 Patent at fig. 3, 3:65 to 4:3 ("The carrier **58** ... includes a seat **66** for the brush seal **62**, a shoulder **68** that provides axial support to the brush seal **62**...."); Markman Hr'g Tr. at 110:20-25 to 111:1-6. Therefore, it would appear that a non-offset tab could achieve foolproofing in claims 3 and 6 if the carrier included a shoulder or similar feature. The '167 Patent does not restrict the carrier's design, nor does UTC provide evidence that would enable this Court to conclude that one ordinarily skilled in the art would automatically conclude that the presence of a vane assembly sideplate and tab facing the second cavity means that the tab must be radially offset from the brush seal in order to achieve foolproofing. Indeed, any such construction of those claims is directly undercut by the language of the specification, which provides that the vane assembly sideplate featured in figures 5 and 6 is merely

"representative" of the type of retaining means claimed, *see* '167 Patent at 5:58, signaling that the vane assembly sideplate can take different forms and could be designed to fit with a carrier so as to achieve foolproofing even when the tab is not offset, as shown, for example in figure 3.FN14

FN14. Though not critical to the Court's decision, figure 5 also indicates that a non-offset tab might achieve some small measure of foolproofing, particularly where a lip is present (as in claim 6, *see infra* pp. 416-17). Thus, according to figure 5 and its written description, the corner of the seat 102 of the stationary carrier 94 would interfere with a non-offset tab 118 (and lip 116) that extended only to the edge of the backing plate 118 or side plate 112, if the brush seal were installed in the reverse. *See* '167 Patent at 4:35-39, fig. 5.

Second, by proposing that the Court rely in part on the depictions of figures 5 and 6, even UTC appears to concede that the references to a vane assembly sideplate and tab facing the second cavity would not alone signal to one ordinarily skilled in the art that claims 3 and 6 describe a tab that is offset. UTC's argument thus relies primarily on the fact that whenever a tab is depicted in connection with a vane assembly sideplate, either in the description provided in the specification or the diagrams, the tab is radially offset from the brush seal.

As UTC quite rightly notes, preferred embodiments are not irrelevant to the correct meaning of claim terms. *See Flex-Rest, LLC v. Steelcase, Inc.*, 455 F.3d 1351, 1361 (Fed.Cir.2006); *Phonometrics*, 133 F.3d at 1466. However, the Federal Circuit has also cautioned that the specification should not be used to import limitations into the claims. *See Agfa Corp.*, 451 F.3d at 1376 ("[The] depiction of a single embodiment in a patent [does not] necessarily limit[] the claims to that depicted scope." (citing *Phillips*, 415 F.3d at 1323)); *accord Verizon Servs. Corp. v. Vonage Holdings Corp.*, 503 F.3d 1295, 1302-03 (Fed.Cir.2007); *Phillips*, 415 F.3d at 1323. Although, as noted previously, the line between interpretation and limitation can be difficult to ascertain, "[m]uch of the time, upon reading the specification ..., it will become clear whether the patentee is setting out specific examples of the invention to accomplish those goals, or whether the patentee instead intends for the claims and the embodiments in the specification to be strictly coextensive." *Phillips*, 415 F.3d at 1323.

Here, the Court believes that the language of the '167 patent indicates that UTC intended figures 5 and 6 to be exemplary only. In fact the specification twice describes those figures as "exemplary." *See* '167 Patent at 2:66, 5:67. Moreover, in reiterating that the embodiments are exemplary, the '167 Patent states that "it should be understood by those skilled in the art that various changes, omissions, and additions may be made thereto, without departing from the spirit and scope of the invention." '167 Patent at 5:67 to 6:1-3. Therefore, to rely on the examples depicted in figures 5 and 6 as limiting claims 3 and 6 would, the Court believes, improperly cross the line and import a limitation from the specification into the claim.

Phonometrics and *Flex-Rest*, do not, as UTC suggests, instruct a different result. Both cases differ from this case because in those cases intrinsic evidence provided additional and stronger support for reading the disputed terms as being defined by the preferred embodiments. Thus, in *Phonometrics* the Federal Circuit affirmed the district court's construction of "call cost register means" to require the limitation that the register display the cost of a call "in progress," even though the words "in progress" appeared nowhere in the claim. However, the Federal Circuit did so because the words of the claim itself provided for "a substantially instantaneous display of cumulative call cost in dollars and cents," and other claim language made "clear that the call cost register ... provides the caller with real time, accurate information about the cost of the call." *Phonometrics*, 133 F.3d at 1466. Therefore, the preferred embodiment only "support[ed] the

court's] construction of the claim language." *Id.* Similarly, in *Flex-Rest*, the Federal Circuit construed the term "sidewall" as "extending above the support surface" primarily because a preferred embodiment and the written description depicted it in that manner and demonstrated that it would not otherwise support the keyboard, which was its asserted function. *See Flex-Rest*, 455 F.3d at 1361. Though, *Flex-Rest* provides some support for UTC's arguments, the case is also distinguishable because the claim at issue provided that the "sidewall" was part of the support structure, and it was clear that the sidewall could not achieve this support function unless it extended outward. Similar clarity is not present here. *Id.*

In summary, because there is insufficient evidence to warrant reading the tab in claims 3 and 6 as limited to a *radially offset* tab, the Court construes "tab" in claims 3 and 6 to be either offset or non-offset. This construction avoids importing a limitation from the specification, and has the added advantage of not reading the preferred embodiments out of the claim, since the tab, as so construed, could be radially offset, as shown in figures 5 and 6. *See Oatey Co. v. IPS Corp.*, 514 F.3d 1271, 1276 (Fed.Cir.2008) ("[The Federal Circuit does] not ... normally ... interpret claim terms in a way that excludes embodiments disclosed in the specification."); *Vitronics*, 90 F.3d at 1583.

2. Lip

The next issue is what meaning to ascribe to the term "lip," which is used in claim 6 in connection with the word "tab." Claim 6, and only claim 6, provides as follows:

The brush seal according to claim 3, wherein the tab includes a lip extending outward from the brush seal, wherein the vane assembly sideplate includes a cut-out adapted to accommodate the lip such that engagement between the lip and cut-out blocks rotation of the brush seal about the longitudinal axis.

'167 Patent at 6:51-56. UTC asks that the term "lip" be construed as "forming an L-shape with the tab." *See UTC's Claim Br.* at 36. PerkinElmer objects to construing the tab as L-shaped. Instead, PerkinElmer contends that the term "lip" must mean "the portion of the tab that extends outward from the brush seal and engages a cut-out in the retaining means," *Defs.' Claim Br.* at 35. The lip can, therefore, have any shape including that of the lip of the edge of a coffee mug.

[16] The Court has little difficulty concluding that the term "lip," as used in claim 6, must include a protrusion or appendage that angles sharply away from main body of the tab, though it need not necessarily be in the shape of the letter "L." It could, for example, be a "P"- or "D"-shaped tab-lip combination. The words of claim 6 itself indicate that the lip is attached to the tab at an angle that would allow it to engage with the cut-out in the vane assembly sideplate to achieve antirotation. Thus, the claim recites, the "tab includes a lip extending outward from the brush seal" and the cut-out of the sideplate accommodates the lip "such that engagement between the lip and cut-out blocks rotation of the brush seal about the longitudinal axis." '167 Patent at 6:51-56. This language indicates that claim 6 envisions a sharply angled protrusion from the tab that would fit into, or engage with, the sideplate. Moreover, as already noted, though the embodiments of an invention should not be used to import limitations, they can provide guidance in interpreting claims. *See Phillips*, 415 F.3d at 1323. In that vein, it is worth noting that the illustrations and descriptions of the invention's preferred embodiments repeatedly depict the tab with a lip as L-shaped. *See '167 Patent* at 4:23-24; 4:60-61, figs. 2, 3, 4, 5, 6. Further, Figure 5, which appears to be the specific embodiment of claim 6, undisputedly provides for tab with a lip that is L-shaped. *See UTC's Claim Br.* at 40; '167 Patent, fig. 5; *cf. Defs.' Claim Reply Br.* at 10-11 (admitting that claim 3 is directed towards figures 5 and 6); *see also Dentsply Int'l, Inc. v. Hu-Friedy Mfg. Co.*, 202 Fed.Appx. 464, 468-69 (Fed.Cir.2006)

(affirming limiting construction of "tip" in part because "the specification describes every preferred embodiment in a similar manner"). Accordingly, the Court concludes that the word "lip" should be read as describing a protrusion or appendage at a sharp angle from the tab, and would include (but would not be limited to) an L-shaped tab. Notably, because the word "lip" appears only in claim 6, the inventions described in claims 1 and 3 have a tab only, but no lip.FN15

FN15. In its opening brief, PerkinElmer also briefly contested the meaning of the term "retaining means" as used in claims 1, 3, and 6, arguing that the term encompassed a structure that is either separate from or part of the "carrier." *See* Defs.' Claim Br. at 33-35. In its opening brief, UTC did not suggest that "retaining means" was a disputed term, *see* UTC's Claim Br. at 59, but in its Reply Brief, UTC did respond briefly to PerkinElmer's assertions, arguing that the "retaining means" must be separate from the carrier, *see* UTC's Claim Reply Br. at 10. PerkinElmer did not address the term "retaining means" in its reply, and neither UTC nor PerkinElmer discussed the term at the Markman hearing or during the supplemental telephonic argument the Court recently held. In view of the fact that the Court construed claims 1, 3, and 6 as describing a stand-alone brush seal and not a brush seal assembly, it is not at all clear to the Court that it must construe the term "retaining means" as used in claims 1, 3, and 6. This is particularly true since PerkinElmer did not address this issue in its Reply Brief and neither party discussed it during the Markman hearing. Accordingly, the Court will not at this time construe the term "retaining means" as used in claims 1, 3 and 6. If either party believes that the construction of the term "retaining means" remains important, that party may move the Court to construe the term "retaining means" by filing a motion to that effect **no later than April 7, 2008**.

*418



IV. Conclusion

In conclusion and for the reasons stated above, the Court construes the disputed terms as follows:

1. Claim 1's preamble is construed as describing the design envelope into which the claimed stand-alone brush seal would fit. Accordingly, claims 1, 3, and 6 describe a stand-alone brush seal and not a brush seal assembly.
2. "Tab" is construed as:
 - a. "an appendage, projection or extension of a brush seal" and is "not limited to flat or rectangular structures with L-shaped cross-sections";
 - b. that does not require machining the seal or support structure;
 - c. and that can be either offset or non-offset from the brush seal.
3. "Lip," as used in claim 6, is construed as a protrusion or appendage at a sharp angle, which can include but is not limited to an L-shaped tab.

In addition, the Court DENIES WITHOUT PREJUDICE TO RENEWAL UTC's Motion for Summary Judgment [doc. # 74] and Defendants' Motion for Summary Judgment of Non-Infringement [doc. # 69] and Motion for Summary Judgment of Invalidity of Claims 1, 3, and 6 [doc. # 73]. Similarly, UTC's Motion to Exclude the Testimony of Braun & O'Meara [doc. # 68] and Defendants' Motions to Exclude the Testimony of Esther Boyes [doc. # 78] and Catherine Lawton [docs. 80, 88] are DENIED WITHOUT PREJUDICE TO RENEWAL. The parties may renew their motions **no later than April 24, 2008** and can incorporate their prior briefs by reference.

IT IS SO ORDERED.

***419**



US005597167A

United States Patent [19]

[11] Patent Number: 5,597,167

Snyder et al.

[45] Date of Patent: Jan. 28, 1997

[54] BRUSH SEAL WITH FOOL PROOFING AND ANTI-ROTATION TAB

5,890,710	3/1992	Flower	27753
5,284,347	2/1994	Pope	27753
5,351,971	10/1994	Short	27753

[75] Inventors: James G. Snyder, Newark, Ohio;
Gregory H. Geraldini, Old Saybrook, Conn.

FOREIGN PATENT DOCUMENTS

0816288	7/1959	United Kingdom	27753
---------	--------	----------------	-------

[73] Assignee: United Technologies Corporation,
Hartford, Conn.

Primary Examiner—Daniel C. DePungo

[21] Appl. No.: 314,034

[57] ABSTRACT

[22] Filed: Sep. 28, 1994

A brush seal assembly includes a tab extending outward and engageable with a brush seal retainer. Various construction details are disclosed that provide a tab that prevents rotation of the brush seal during use and also prevents reverse installation of the brush seal assembly. In a particular embodiment, a brush seal assembly for installation within a carrier includes a tab that fits radially within a cut-out in a retaining means. Engagement with the cut-out prevents rotation. The tab extends outward from the low pressured side of the brush seal assembly. If installed in a reverse orientation, the tab engages the carrier to block installation of the retaining means.

[51] Int. Cl.⁶ F16J 15/18
 [52] U.S. Cl. 277/83; 277/136
 [58] Field of Search 277/53, 136, 137,
 277/188 R, 189, 55

[56] References Cited

U.S. PATENT DOCUMENTS

3,552,753	1/1971	Mierley, Sr.	277/137
5,066,025	11/1991	Furman	277/52

18 Claims, 4 Drawing Sheets

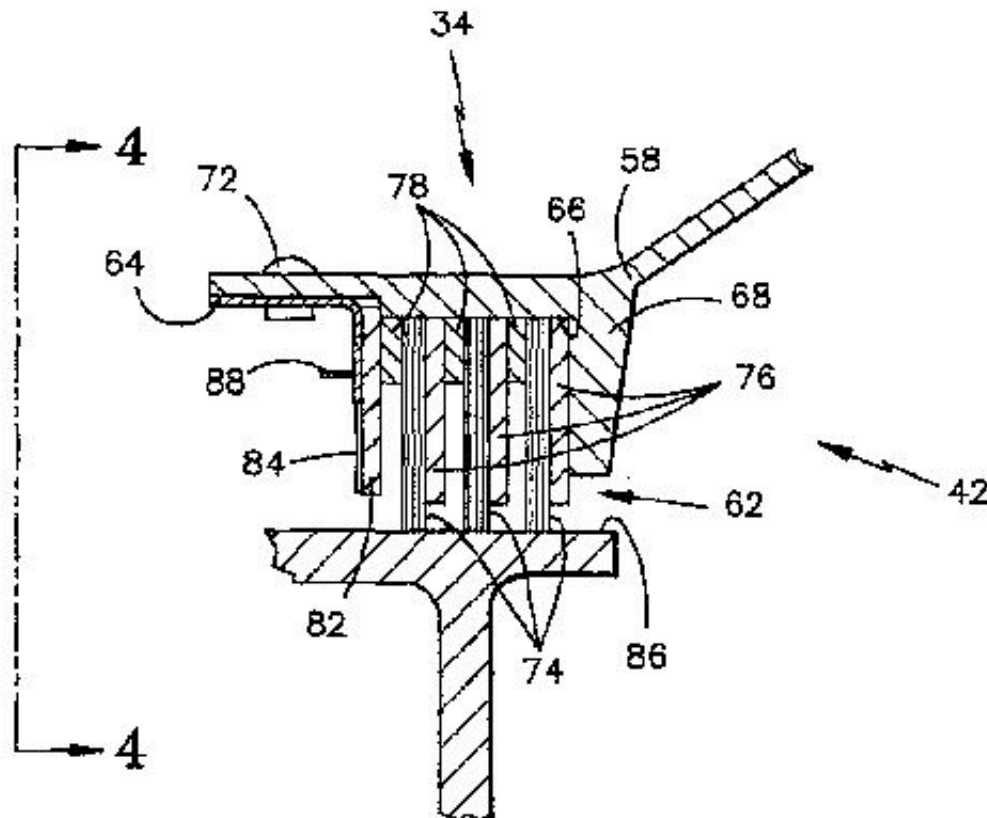

FIG. 1

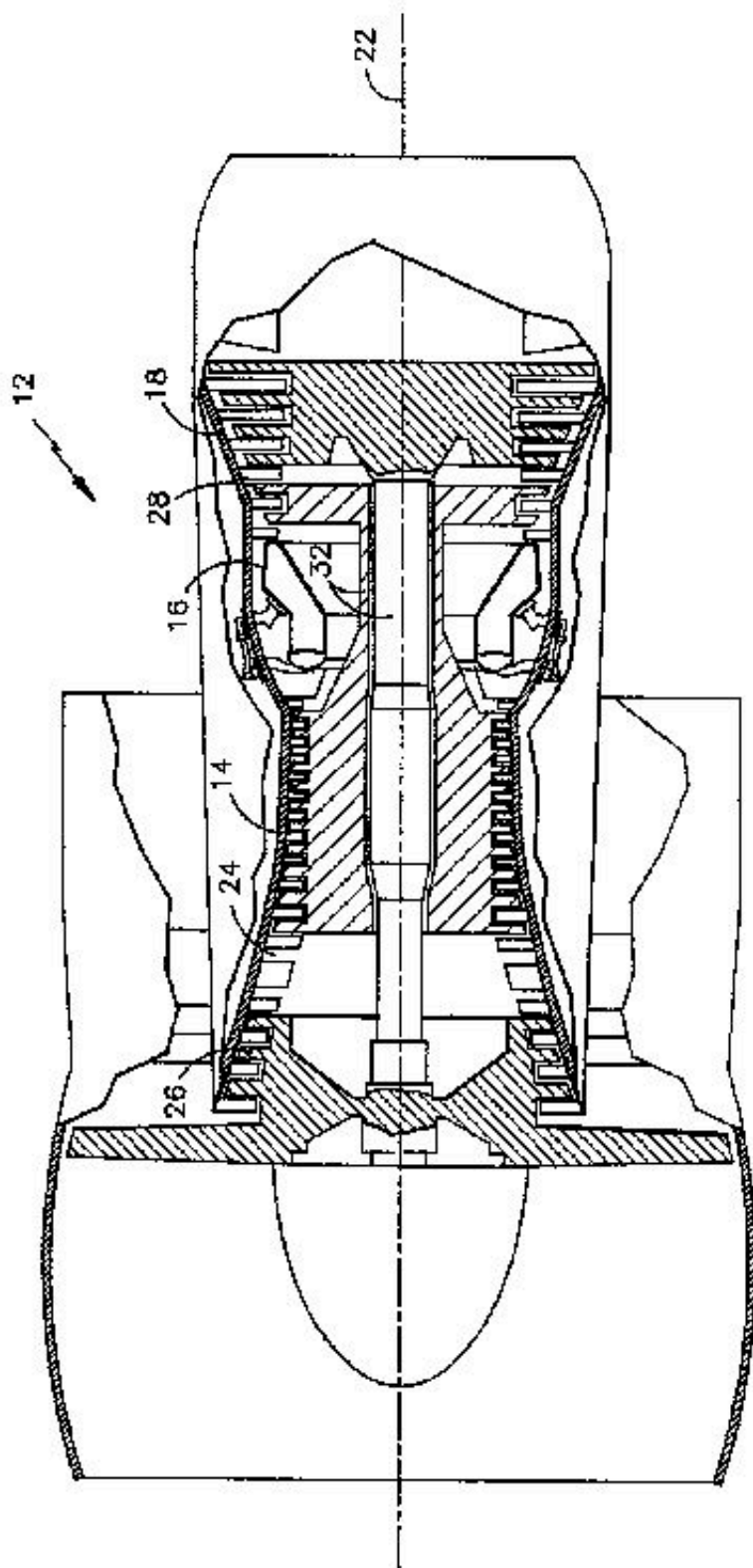

FIG. 2

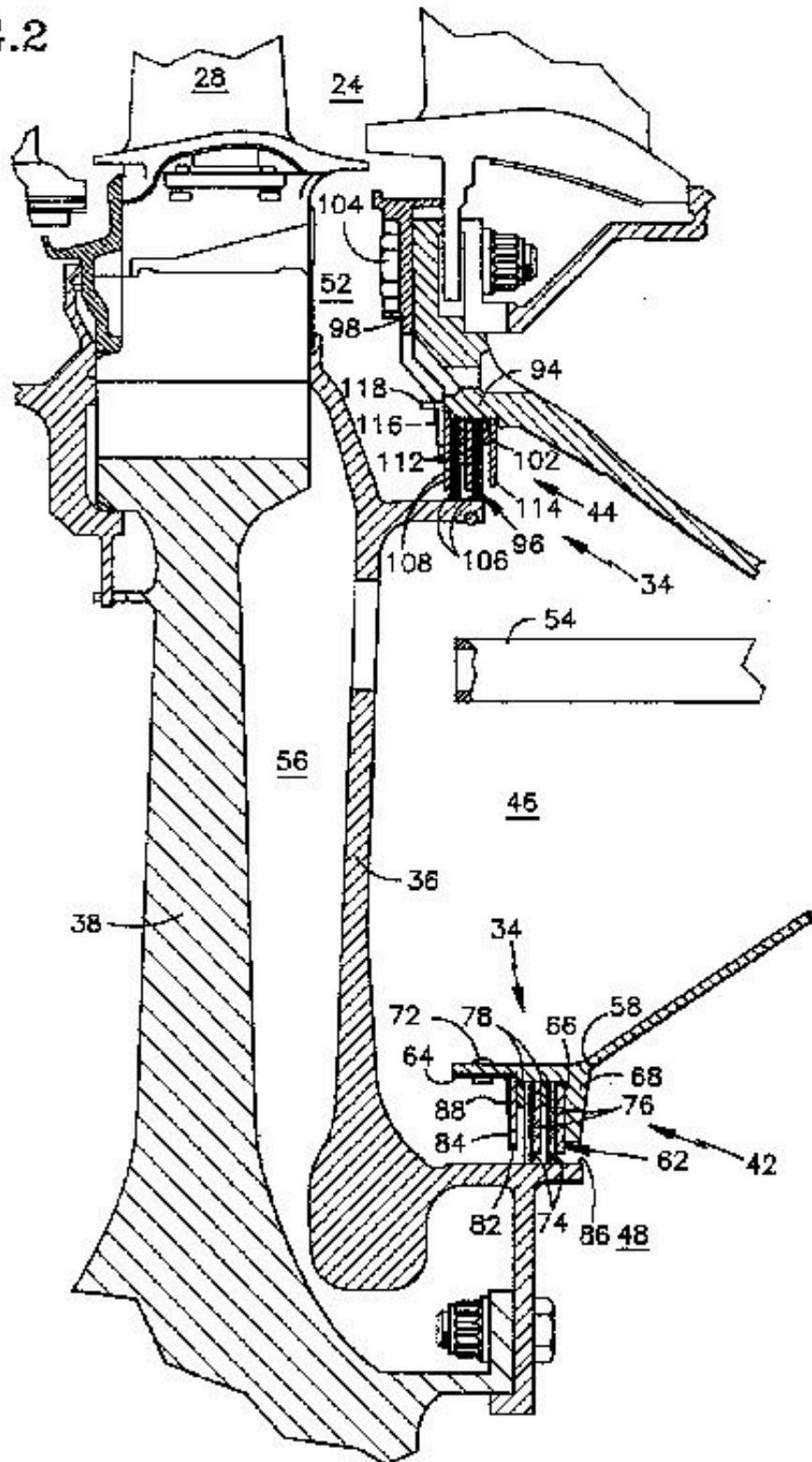

FIG. 3

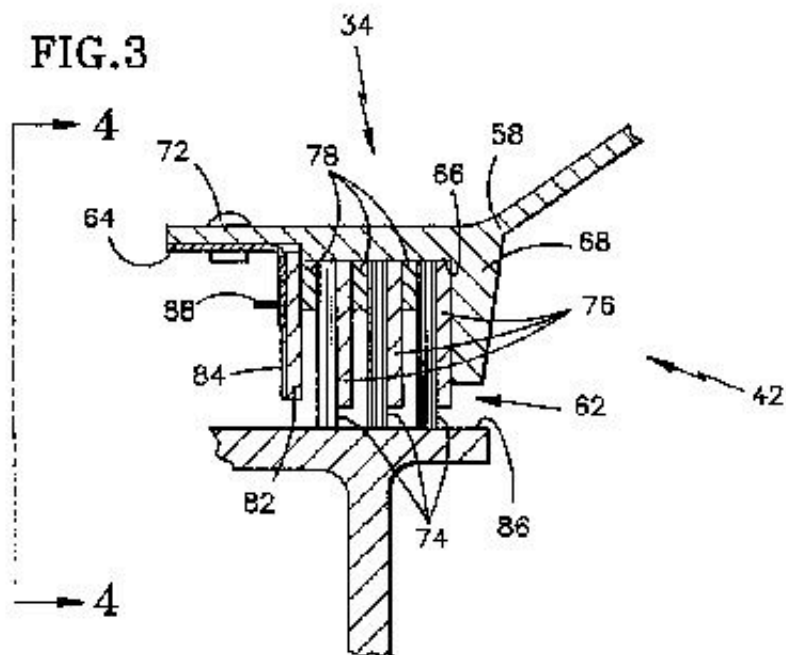

FIG. 4

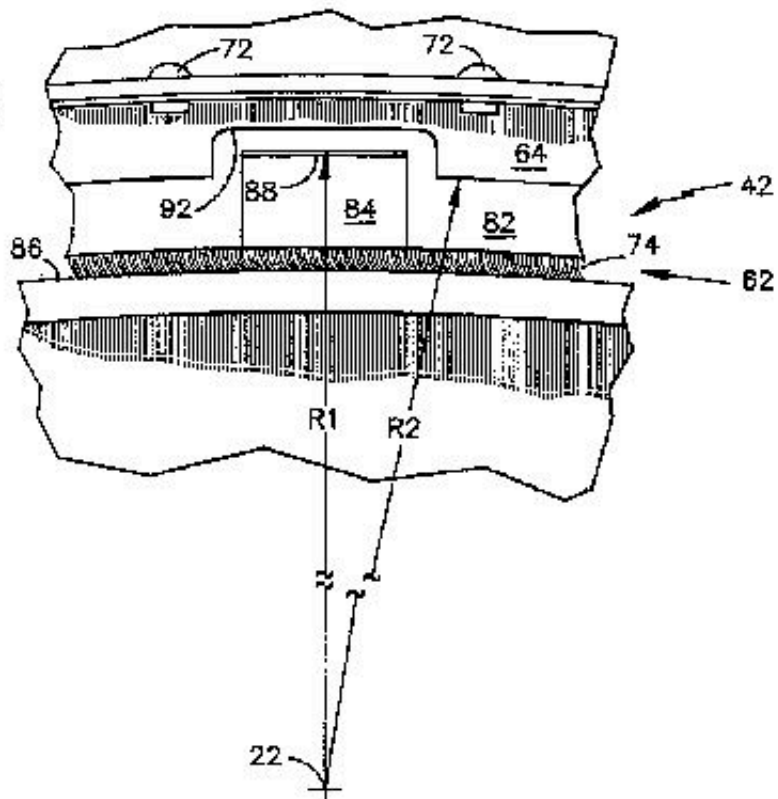

FIG. 5

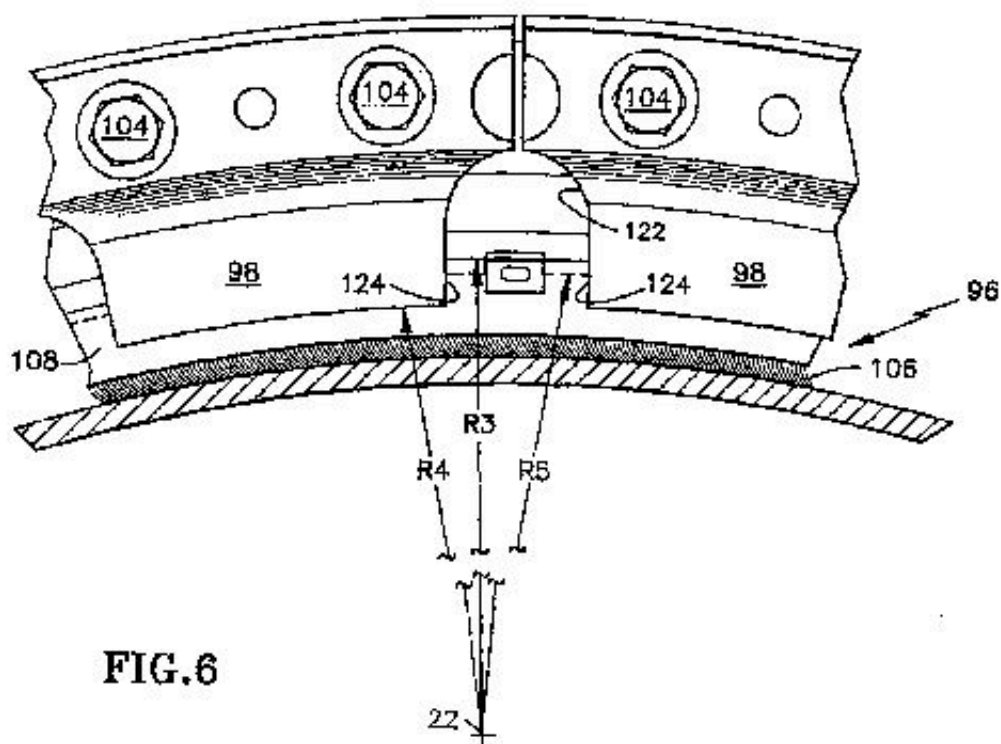
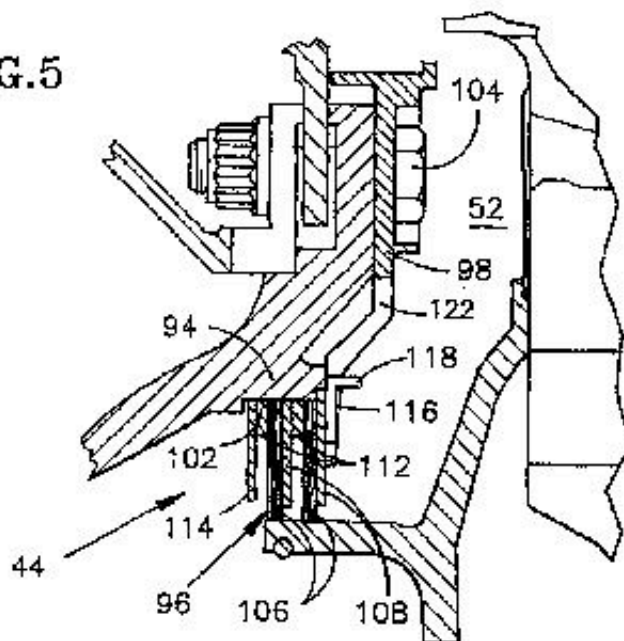

FIG. 6

FIG. 5 and FIG. 6

BRUSH SEAL WITH FOOL PROOFING AND ANTI-ROTATION TAB

TECHNICAL FIELD

The present invention relates to brush seals, and more particularly to brush seals used in turbomachines.

Although the invention was developed in the field of aircraft engines it has application to other fields where brush seals are used to block fluid flow between a rotating and a stationary surface.

BACKGROUND OF THE INVENTION

A brush seal is a commonly used device for sealing between a rotating component, such as a shaft, and an adjacent stationary surface. The brush seal includes one or more arrays of brushes that are generally radial in orientation and extend between the rotating surface and the stationary surface. Each array of brushes is sandwiched between a backing plate and a side plate. The backing plate is on the lower pressure side and extends nearly the length of the brushes to prevent the bristles of the brushes from bending away from the high pressure side.

The bristles are typically angled slightly relative to the radial direction and away from the direction of rotation. This feature prevents buckling of the bristles during use and reduces wear. Another source of wear results from the rotation of the seal induced by contact with the rotating surface.

Reverse installation of the annular brush seals is also a contributor to wear and improper functioning of the seal. If installed backwards, the backing plate is on the high pressure side and therefore provides no support to prevent bending of the bristles into the low pressure side. This bending reduces the effectiveness of the sealing contact between the brush seal and the rotating surface. Further, the bristles will be angled into the direction of rotation and, as a result, buckling of the bristles will be encouraged rather than discouraged. This also contributes to reducing the effectiveness of the seal. In addition, the brush seal may not seat properly if installed backwards, which may lead to higher levels of vibration and increase the risk of damage to the seal.

Prior art devices to prevent reverse installation include provision of a pin that is received by an opening machined into the side plate of the brush seal but not the backing plate. Another prior art device includes a lip machined into the side plate that cooperates with a groove machined into the support structure. Brush seals are typically made by sandwiching the bristles between the side plate and the backing plate and then welding the sandwiched apparatus together. After bonding, the assembled brush seal is machined to form the opening or lip that is needed to prevent reverse installation.

A recent example of a brush seal assembly that prevents reverse installation is described in U.S. Pat. No. 5,066,025, issued to Hanrahan and entitled "Brush Seal Assembly". In this device, a recess is machined into the support structure that defines the carrier for the brush seal. The recess is sized to accept the shorter side plate but not the longer backing plate. Reverse installation will offset the axial position of the seal such that a retaining ring cannot be installed. Therefore, reverse installation is precluded without requiring special machining of the brush seal.

The above art notwithstanding, scientists and engineers under the direction of Applicants' Assignee are working to develop improved brush seals.

DISCLOSURE OF THE INVENTION

The present invention is predicated in part upon the recognition that machining the brush seal after fabrication weakens the weld bond between the brush stages and between the backing plates and sideplates. In effect, the machining of prior art brush seals to form a fool proofing lip on the brush seals removes a portion of the weld bond. The weakened brush seal is more susceptible to damage during use.

According to the present invention, a brush seal includes a tab that engages a brush seal retaining means to block rotation of the brush seal and prevent improper installation of the brush seal.

According to a specific embodiment of the present invention, the retaining means is a ring fixedly disposed on a carrier and having a cutout, and the brush seal includes a lip extending outward from the brush seal. The cut-out in the ring is sized to accommodate the lip such that engagement between the lip and the cut-out prevents rotation.

According to another specific embodiment, the retaining means is a vane assembly sideplate fastened to an adjacent vane assembly and having a cut-out, and the brush seal includes a lip extending outward from the brush seal. The cut-out in the sideplate is sized to accommodate the lip such that engagement between the lip and the cut-out prevents rotation.

According to another embodiment of the present invention, a method of installing a brush seal includes the steps of: inserting the brush seal into an annular spacing between the carrier and the rotating surface, engaging the retaining means with the brush seal such that the tab is disposed within the cut-out of the retaining means, and fastening the retaining means into a fixed relationship to the carrier.

A principle feature of the present invention is the tab extending outward from the brush seal. This feature provides the advantage minimized wear of the brush seal by preventing rotation of the brush seal. The brushes of the brush seal are in sealing contact with the rotating surface. This contact encourages the annular brush seal to rotate in the direction of rotation of the rotating surface. The tab fits within a cut-out in the retaining means and engages the sides of the cut-out to block any significant rotational movement of the brush seal. Another advantage of the tab is that it foolproofs the installation of the brush seal. The tab is radially located such that if the brush seal were installed backwards, i.e. the backing plate facing the high pressure cavity, the tab interferes with the carrier. This interference prevents the retaining means from being engaged with both the carrier and the brush seal and, therefore, the brush seal cannot be fixedly retained by the retaining means.

A further advantage of the present invention is the increased durability of the brush seal as a result of the elimination of machining of the brush seal to produce the openings or lips used in the prior art. In addition, the present invention does not require machining of a recess or groove into the support structure. Elimination of this step minimizes the cost of the installation of brush seals.

The foregoing and other objects, features and advantages of the present invention become more apparent in light of the following detailed description of the exemplary embodiments thereof, as illustrated in the accompanying drawings.

BRIEF DESCRIPTION OF THE DRAWINGS

FIG. 1 is a cross-sectional side view of a gas turbine engine.

FIG. 2 is a sectioned, side view of rotor stage of the gas turbine engine.

FIG. 3 is a sectional view of a brush seal having an anti-rotation tab.

FIG. 4 is an axial view of the brush seal, taken along line 4-4 of FIG. 3.

FIG. 5 is a sectional view of an alternate embodiment of a brush seal having an anti-rotation tab.

FIG. 6 is an axial view of the alternate embodiment of the brush seal, taken along line 6-6 of FIG. 5.

BEST MODE FOR CARRYING OUT THE INVENTION

Illustrated in FIG. 1 is a gas turbine engine 12 having a compressor 14, combustor 16, and turbine 18 disposed sequentially about a longitudinal axis 22 and having a flow path 24 extend therethrough. Working fluid flowing through the compressor 14 is engaged by a plurality of rotating compressor blades 26 to transfer energy to the working fluid. Within the combustor 16, fuel is mixed with the working fluid and the mixture is combusted. The working fluid, now consisting of the products of combustion, is then flowed through the turbine 18. Turbine rotor blades 28 within the turbine 18 remove energy from the working fluid. A portion of this energy is used to rotate the shafts 32 interconnecting the compressor 14 and turbine 18.

The high temperature associated with the combustion and the products of combustion may lead to damage to the components within the turbine 18. To reduce the likelihood of such damage occurring, cooling fluid is drawn from the compressor 14 and flowed into the turbine 18. This cooling fluid flows around the combustor 16 and thereby bypasses the transfer of heat from the combustion.

Sealing means 34 are used to ensure that the cooling fluid does not mix with the hot working fluid within the turbine 18 prior to cooling the turbine structural components. FIGS. 2-6 disclose sealing means 34 used in conjunction with a disk sideplate 36 to direct cooling fluid over a first stage rotor disk 38 and into an array of first stage rotor blades 28.

The sealing means 34 includes a radially inner brush seal assembly 42 and a radially outer brush seal assembly 44. The inner brush seal assembly 42 discourages fluid flow between a cooling cavity 46 and a radially inner cavity 48 defined by the separation between the shaft 32 and the adjacent turbine structure. The outer brush seal assembly 44 discourages fluid flow between the cooling cavity 46 and a vane cavity 52 disposed between the rotor blade assembly and an upstream vane assembly.

A tangential on-board injector 54 (TOBI) supplies cooling fluid into the cooling cavity 46. Cooling fluid flows from this cavity 46 into a disk cavity 56 defined by the axial separation of the disk sideplate 36 and the rotor disk 38. Passages (not shown) in the disk 38 and rotor blade 28 provide means for flowing cooling fluid through the disk 38 and rotor blade 28 to provide cooling of those structures.

The inner brush seal assembly 42 is shown in more detail in FIG. 3. The inner brush seal assembly 42 includes a stationary carrier 58, a brush seal 62, and a retainer 64. The carrier 58 is an extension of the adjacent support structure and includes a seat 66 for the brush seal 62, a shoulder 68

that provides axial support to the brush seal 62, and a fastener 72. The brush seal 62 is disposed within the seat 66 and axially adjacent to the shoulder 68. A radially directed interference between the seat 66 and brush seal 62 results in a "snap-fit". The retainer 64 is disposed on the axially opposite side of the brush seal 62 from the shoulder 68 and, in conjunction with the shoulder 68, retains the brush seal 62 into its axial position. The retainer 64 is fixedly attached to the carrier 58 by engagement with the fastener 72.

The brush seal 62 includes three arrays of brushes 74, a combination of a backing plate 76 and a sideplate 78 for each array of brushes 74, a windage cover 82, and a tab 84. Each of the arrays of brushes 74 extends radially inward toward a rotating surface 86 and is angled (see FIG. 4) in the direction of rotation. The backing plates 76 and sideplates 78 are typical of those commonly used in conventional brush seals. The backing plates 76 are on the low pressure side and the sideplates 78 are on the high pressure side. The windage cover 82 faces into the cooling cavity 46. In this position, the windage cover 82 blocks the arrays of brush seals 62 from contact with cooling fluid that may be rotating about the annulus of the cooling cavity 46.

The tab 84 is L-shaped in cross-section such that a lip 88 is defined on the radially outer edge. The tab 84 is tack welded onto the windage cover 82 and extends radially outward to a radius R1 outward of the mean radius R2 of the retainer 64. To accommodate the radial extension of the tab 84, the retainer 64 includes a cut-out 92 extending radially and circumferentially about the tab 84.

The outer brush seal assembly 44 illustrates another embodiment of the present invention. The outer brush seal assembly 44 is shown in more detail in FIGS. 5 and 6. The outer brush seal assembly 44 includes a stationary carrier 94, a brush seal 96, and a plurality of vane cover plates 98. The carrier 94 is an extension of the adjacent support structure and includes a seat 102 for the brush seal 96. As with the inner brush seal assembly 42, a snap-fit exists between the brush seal 96 and the seat 102. The vane cover plates 98 are disposed on the low pressure side of the brush seal 96 to provide axial support to the brush seal 96 and, in conjunction with the carrier 94, retains the brush seal 96 into its axial position. The vane cover plates 98 are spaced circumferentially and each is fixedly attached to the carrier 94 by a mechanical fastener 104.

The outer brush seal assembly 44 includes two arrays of brushes 106, a combination of a backing plate 108 and a sideplate 112 for each array of brushes 106, a windage cover 114, and a tab 116. Each of the arrays of brushes 106 extends radially inward toward a rotating surface of the disk sideplate 36 and is angled (see FIG. 6) in the direction of rotation. The backing plates 108 are similar to those of the inner brush seal 62, except that the tab 116 is fixedly attached to the side of the backing plate 108 on the rotor disk 38 side. The windage cover 114 faces into the cooling cavity 46. As with the inner brush seal assembly 42, the windage cover 114 blocks the arrays of brushes 106 from contact with cooling fluid that may be rotating about the annulus of the cooling cavity 46.

The tab 116 is also L-shaped in cross-section such that a lip 118 is defined on the radially outer edge. The tab 116 is tack welded onto the downstream backing plate 108 and extends radially outward to a radius R3 outward of the mean radius R4 of the vane cover plate 98 and also outward of the radius R5 of the carrier 94. To accommodate the radial extension of the tab 116, the vane cover plate 98 includes a cut-out 122 extending radially and circumferentially about

the tab 116. As shown in FIG. 6, the cut-out 122 is defined by the adjacent scalloped corners 124 of the circumferentially spaced vane cover plates 98.

During operation of the gas turbine engine 12, cooling fluid is ejected from the TOBI 54 and flows into the cooling cavity 46. This cooling fluid has a positive pressure differential with the fluid within the vane cavity 52, the disk cavity 56, and the inner cavity 48. As a result, fluid is urged to escape through the inner brush seal and outer brush seal assemblies 42,44. The pressure differential between the cooling cavity 46 and the other cavities 48,52 presses the brush seals 62,96 in the downstream direction. For the inner brush seal 62, the shoulder 68 of the carrier 58 provides axial support against this force; for the outer brush seal 96, the vane cover plates 98 provide the axial support against this force.

As the shaft 32 and rotor disk 38 rotates, the bristles of the brush seals 62,96 are engaged by the rotating surfaces. This engagement produces a circumferential force on the brush seals 62,96. The circumferential force is reacted by the snap-fit arrangement of the brush seals 62,96 and seats 66, 102 and by the tab 84 on the inner brush seal 62 seating against the side of the cut-out 92 of the retainer 64 and the tab 116 on the outer brush seal 96 seating against the side of the scalloped corner 124 of the vane cover plate 98. As a result of these engagements, the brush seals 62,96 are prevented from rotating.

The brush seals are assembled into the support structure in the following manner. For the inner brush seal assembly 42, the brush seal 62 is oriented such that the backing plates 76 are on the side of the brush seal 62 facing the inner cavity 48. The brush seal 62 is inserted into position on the carrier 58 and seated against the shoulder 68 of the carrier 58. The retainer 64 is positioned over the windage cover 82 of the inner brush seal 62 such that the tab 84 and lip 88 are within the cut-out 92. The fastener 72 is then engaged with the retainer 64 and the carrier 58. In the event that the brush seal 62 is attempted to be installed backwards, i.e. with the backing plate 76 on the side of the brush seal 62 facing the cooling cavity 46, the lip 88 of the tab 84 will engage the shoulder 68 of the carrier 58 and thereby axially offset the brush seal 62 from the shoulder 68 of the carrier 58. This axial offset will prevent the retainer 64 from being engageable with the carrier 58 via the fastener 72.

For the outer brush seal assembly 44, the brush seal 96 is oriented such that the backing plates 108 are on the side of the brush seal 96 facing the vane cavity 52. The brush seal 96 is inserted into position on the carrier 94. The vane cover plate 98 is positioned over the downstream backing plate 108 of the outer brush seal 96 such that the tab 116 and lip 118 are within the cut-out 122. The fastener 104 is then engaged with the vane cover plate 98. In the event that the brush seal 96 is attempted to be installed backwards, i.e. with the backing plate 108 on the side of the brush seal 96 facing the cooling cavity 46, the lip 118 of the tab 116 will engage the support structure and prevent installation of the outer brush seal 96.

The retainer 64 and the vane cover plate 98 disclosed in FIGS. 2 to 6 are representative of retaining means that are engageable with the brush seals to fixedly retain the brush seals 62,96 to the carriers 58,94. In addition, the quantity of brush seal arrays are shown as two for the outer brush seal 96 and three for the inner brush seal 62. It should be apparent to those skilled in the art that the invention is applicable to brush seals having one or more arrays of brushes.

Although the invention has been shown and described with respect to exemplary embodiments thereof, it should be

understood by those skilled in the art that various changes, omissions, and additions may be made thereto, without departing from the spirit and scope of the invention.

What is claimed is:

1. A brush seal for discouraging fluid flow through an annular spacing between a stationary carrier and a rotating surface proximate to the carrier, the annular spacing disposed about a longitudinal axis and separating a first cavity and a second cavity, the first cavity having a higher pressure than the second cavity, the carrier including a retaining means being engageable with the brush seal and thereby fixedly retain the brush seal to the carrier with the brush seal in an installed condition, the brush seal including:

- at least one brush stage, the brush stage including:
 - an array of brushes extending through the spacing;
 - a backing plate adjacent the side of the array of brushes, the backing plate facing the second cavity with the brush seal in the installed condition; and
 - a sideplate adjacent the opposite side of the array of brushes, and
- a tab disposed in a fixed relationship to the brush stage, the tab engaging the retaining means to block rotation of the brush stage about the longitudinal axis, and the tab extending outward from the brush seal, the tab being located such that if the brush seal is installed with the backing plate between the array of brushes and the first cavity, the tab interfaces with the carrier to thereby prevent fixed retention of the brush seal to the carrier by the retaining means.

2. The brush seal according to claim 1, wherein the retaining means is a ring fixedly disposed on the carrier and extending over the brush seal, and wherein the tab is disposed on the side of brush seal facing the first cavity.

3. The brush seal according to claim 1, wherein the retaining means is vane assembly sideplate, the vane assembly sideplate being fastened to an adjacent vane assembly and extending over the brush seal, wherein the tab is disposed on the side of the brush seal facing the second cavity.

4. The brush seal according to claim 1, wherein the tab includes a lip extending outward from the brush seal, wherein the retaining means includes a cut-out adapted to accommodate the lip such that engagement between the lip and cut-out blocks rotation of the brush seal about the longitudinal axis.

5. The brush seal according to claim 2, wherein the tab includes a lip extending outward from the brush seal, wherein the ring includes a cut-out adapted to accommodate the lip such that engagement between the lip and cut-out blocks rotation of the brush seal about the longitudinal axis.

6. The brush seal according to claim 3, wherein the tab includes a lip extending outward from the brush seal, wherein the vane assembly sideplate includes a cut-out adapted to accommodate the lip such that engagement between the lip and cut-out blocks rotation of the brush seal about the longitudinal axis.

7. A brush seal assembly for discouraging fluid flow through an annular spacing separating a first cavity from a second cavity, the annular spacing disposed about a longitudinal axis, the first cavity having a higher pressure than the second cavity, the brush seal assembly including a stationary carrier, a rotating surface proximate to the carrier, at least one brush stage, and a tab disposed in a fixed relationship to the brush stage, the carrier including a retaining means being engageable with the brush stage to thereby fixedly retain the brush stage to the carrier, the brush stage including an array of brushes extending through the spacing, a backing plate

7

adjacent the side of the array of brushes, the backing plate facing the second cavity, and a sideplate adjacent the opposite side of the array of brushes, the tab engaging the retaining means to block rotation of the brush stage about the longitudinal axis, and the tab extending outward from the brush stage the tab being located such that if the brush stage is installed with the backing plate between the array of brushes and the first cavity the tab interfaces with the carrier to thereby prevent fixed retention of the brush seal to the carrier by the retaining means.

8. The brush seal assembly according to claim 7, wherein the retaining means is a ring fixedly disposed on the carrier and extending over the brush stage, and wherein the tab is disposed on the side of brush stage facing the first cavity.

9. The brush seal assembly according to claim 7, wherein the retaining means is vane assembly sideplate, the vane assembly sideplate being fastened to an adjacent vane assembly and extending over the brush stage, wherein the tab is disposed on the side of the brush stage facing the second cavity.

10. The brush seal assembly according to claim 7, wherein the tab includes a lip extending outward from the brush stage, wherein the retaining means includes a cut-out adapted to accommodate the lip such that engagement between the lip and cut-out blocks rotation of the brush stage about the longitudinal axis.

11. The brush seal assembly according to claim 8, wherein the tab includes a lip extending outward from the brush stage, wherein the ring includes a cut-out adapted to accommodate the lip such that engagement between the lip and cut-out blocks rotation of the brush stage about the longitudinal axis.

12. The brush seal assembly according to claim 9, wherein the tab includes a lip extending outward from the brush stage, wherein the vane assembly sideplate includes a cut-out adapted to accommodate the lip such that engagement between the lip and cut-out blocks rotation of the brush stage about the longitudinal axis.

13. A method to install a brush seal into a turbomachine, the turbomachine including a stationary carrier, a rotating surface proximate to the carrier, an annular spacing defined by the separation between the carrier and the rotating surface, the annular spacing disposed about a longitudinal axis and separating a first cavity and a second cavity, the first cavity having a higher pressure than the second cavity, the carrier including a retaining means being engageable with the brush seal to thereby fixedly retain the brush seal to the carrier with the brush seal in an installed condition, the retaining means having a cut-out, the brush seal including at least one brush stage and a tab disposed in a fixed relation-

8

ship to the brush stage, the brush stage including an array of brushes extending through the spacing, a backing plate adjacent the side of the array of brushes, the backing plate facing the second cavity with the brush seal in the installed condition, and a sideplate adjacent the opposite side of the array of brushes, the tab engaging the cut-out of the retaining means to block rotation of the brush stage about the longitudinal axis, and the tab extending outward from the brush seal the tab being located such that if the brush seal is installed with the backing plate between the array of brushes and the first cavity the tab interfaces with the carrier to thereby prevent fixed retention of the brush seal to the carrier by the retaining means, the method including the steps of:

inserting the brush stage into the annular spacing with the backing plate facing the second cavity;

engaging the retaining means with the brush seal such that the tab is disposed within the cut-out; and

fastening the retaining means into a fixed relationship to the carrier.

14. The method according to claim 13, wherein the retaining means is a ring, wherein the step of engaging the retaining means with the brush seal includes engaging the ring with the side of the brush seal facing the first cavity, and wherein the step of fastening the retaining means includes fastening the ring directly to the carrier.

15. The method according to claim 13, wherein the retaining means is a vane assembly sideplate, wherein the step of engaging the retaining means with the brush seal includes engaging the vane assembly sideplate with the side of the brush seal facing the second cavity, and wherein the step of fastening the retaining means includes fastening the vane assembly sideplate to an adjacent vane assembly.

16. The method according to claim 13, wherein the retaining means includes a lip extending outward from the brush seal, and wherein the step of engaging the retaining means with the brush seal includes inserting the lip into cut-out.

17. The method according to claims 14, wherein the retaining means includes a lip extending outward from the brush seal, and wherein the step of engaging the retaining means with the brush seal includes inserting the lip into cut-out.

18. The method according to claims 15, wherein the retaining means includes a lip extending outward from the brush seal, and wherein the step of engaging the retaining means with the brush seal includes inserting the lip into cut-out.

* * * * *