

United States District Court,
N.D. California, San Jose Division.

XOFT, INC,
Plaintiff.

v.
CYTYC CORPORATION; and Proxima Therapeutics, Inc,
Defendants.

No. C-05-05312 RMW

April 27, 2007.

James W. Geriak, Kurt T. Mulville, Mark Stirrat, Monte M.F. Cooper, for Plaintiff.

Henry C. Bunsow, Henry C. Su, for Defendants.

CLAIM CONSTRUCTION ORDER

RONALD M. WHYTE, United States District Judge.

Xoft, Inc. sued Cytyc Corporation and one of its subsidiaries, Cytyc Surgical Products II, Inc., (collectively "Cytyc") for a declaratory judgment of non-infringement and invalidity of U.S. Patent Nos. 5,913,813 and 6,413,204. Cytyc responded by filing counterclaims for infringement of the same patents and currently asserts that Xoft infringes six claims of the ' 813 patent FN1 and twenty claims of the ' 204 patent FN2. The application for the ' 204 patent was filed as a continuation-in-part of the ' 813 patent; the former purports to incorporate by reference the latter. ' 204 patent, col. 1, ll. 10-11. The parties seek construction of eight terms or phrases from the ' 813 patent and twenty-one terms or phrases from the ' 204 patent.

I. BACKGROUND

The patents-in-suit are directed to methods and apparatus for treatment of proliferative tissue diseases. The prior art discloses that a radiation source can be implanted at a tumor site to irradiate any remaining diseased tissue; this process is known as interstitial brachytherapy. The parties agree that for the purposes of this suit, the strength of radiation may be assumed to decrease with the square of the distance from the radiation source. The graph of the equation $y = 1 / x^2$ thus can be used as an approximation of the relationship between the radiation strength and distance. The graph, shown below, illustrates that the radiation strength close to the radiation source is disproportionately higher than that at a relatively small distance away from the radiation source.

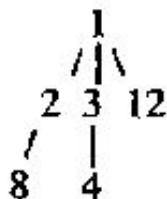

This shows one of the problems encountered in radiation therapy, namely, that tissue close to the radiation source may get more radiation than a physician would prefer. When using interstitial therapy, a physician may wish to give all tissue within a certain distance-say, for example, 3 centimeters-from the tumor site a certain dose of radiation. However, tissue closer to the tumor site-say, 1 centimeter-will receive a much higher dose of radiation because of the inverse-square relationship. This means that healthy tissue near the tumor site may be killed by the radiation, which is an undesirable result.

Following the teachings of the patents-in-suit, the very high levels of radiation near the source can be avoided by simple mechanical means. Surrounding the radiation source on all sides with empty space (or some material other than living tissue) prevents the highest levels of radiation from affecting living tissue, giving the tissue a radiation dose profile that looks something like this:

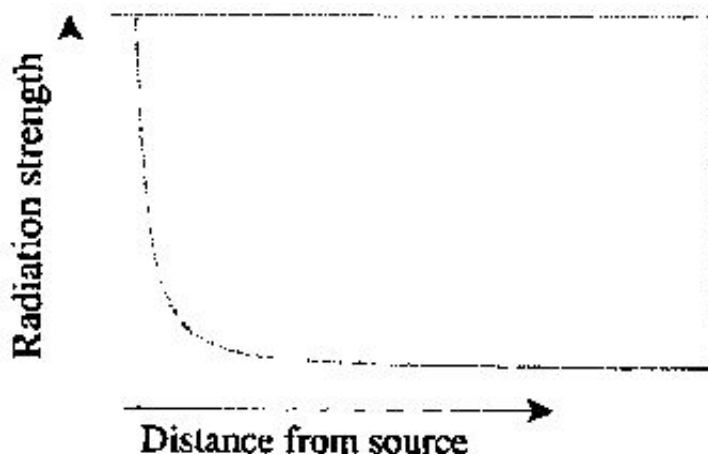

II. ANALYSIS

A. Terms of the '813 patent

"Inner spatial volume"

<i>Cytoc's proposed construction</i>	<i>Xoft's proposed construction</i>
A region of space surrounded by an outer spatial volume that is defined by a closed inflatable chamber	Inner balloon in two-balloon device or spherical solid radionuclide in one-balloon device

The summary of the invention provides that

it is possible to deliver a desired radiation dose at a predetermined radial distance from a source of radioactivity by providing a first spacial ^[FN3] volume at the distal end of a catheter and a second spacial volume defined by a surrounding of the first spatial volume by a polymeric film wall where the distance from the spatial volume ^[FN4] and the wall is maintained substantially constant over their entire surfaces. One of the inner and outer volumes is filled with either a fluid or a solid containing a radionuclide(s) while the other of the two volumes is made to contain either a low radiation absorbing material, e.g., air or even a more absorptive material, such as an x-ray contrast fluid. Where the radioactive material comprises the core, the surrounding radiation absorbing material serves to control the radial profile of the radioactive emissions from the particular one of the inner and outer volumes containing the radionuclide(s) so as to provide a more radially uniform radiation dosage in a predetermined volume surrounding the outer chamber. Where the core contains the absorbent material, the radial depth of penetration of the radiation can be tailored by controlling the core size.

'813 patent, col. 1, l. 50-col. 2, l. 3. The first two claims of the ' 813 patent read:

1. Apparatus for delivering radioactive emissions to a body location with a uniform radiation profile, comprising:

(a) a catheter body member having a proximal end and distal end;

(b) an inner spatial volume disposed proximate the distal end of the catheter body member;

(c) an outer, closed, inflatable, chamber defined by a radiation transparent wall affixed to the body member proximate the distal end thereof in surrounding relation to the inner spatial volume with a predetermined constant spacing between said inner spatial volume and the radiation transparent wall;

(d) a material containing a radionuclide(s) disposed in one of the inner spatial volume and outer chamber; and

(e) means disposed in the other of the inner spatial volume and outer chamber for rendering uniform the radial absorbed dose profile of the emissions from the one of the inner spatial volume and outer chamber containing the radionuclides.

2. The apparatus as in claim 1 wherein said inner spatial volume is an inner closed, chamber defined by a further radiation transparent wall.

'813 patent, col. 4, ll. 32-54. Since all claims of this patent other than claim 1 depend from claim 1, construction of "inner spatial volume" is critical.

In most embodiments of the invention disclosed in the patent specification, the inner spatial volume is a region of space surrounded by an outer spatial volume that is defined by a closed inflatable chamber. *See* '813 patent, col. 2, ll. 44-63; col. 3, ll. 9-16, 42-48; col. 4, ll. 16-20; figs. 1, 3-5. However, the patentee drafted the claims in such a way as to make clear that the inner spatial volume was not necessarily so limited:

Those skilled in the art will appreciate that instead of having the inner spatial volume **30** defined by a

generally spherical polymeric film wall as at **32**, the catheter body member **12** may have a solid spherical radiation emitting material in which event that solid sphere would be surrounded with the outer spherical wall **36** with the spatial volume therebetween occupied by a radioactive ray absorbent material, such as air, water or a contrast material.

'813 patent, col. 2, ll. 55-63.

Although somewhat awkwardly worded, the language of the patent allows for the inner volume to be defined by something other than a region enclosed by a polymeric wall. As Cytac points out, Xoft's construction conflates the boundary of the volume with the volume itself. Cytac's proposed construction, however, is a paraphrasing of the language of claim 1 that only clarifies a little the language of the patent. Furthermore, Cytac's proposed construction would exclude an inner volume defined by a solid sphere, and thus cannot be correct.

Xoft objects that an abstract concept like a region of space cannot be part of an apparatus. Xoft is correct. However, the language of the patent does not imply that the inner volume is ever defined by something other than a physical object. In all embodiments of the invention disclosed in the '813 patent, the boundary of the inner volume is either a polymeric film wall or the edge of a solid sphere. Furthermore, it would seem difficult to fill one volume with radioactive liquid and the other with another fluid if the two volumes were not separated by some structure (which would necessarily be the outer boundary of the inner spatial volume.) See '813 patent, col. 1, ll. 57-62. The patent is even entitled "Double-Wall Balloon Catheter for Treatment of Proliferative Tissue." Xoft's expert, Dr. Lovoi, acknowledged that an "inner spatial volume" is a volume that is inside another volume. Lovoi Dep. at 101:25-102:7. The court defines "inner spatial volume" as "a region of space surrounded by an outer spatial volume and either enclosed by a polymeric film wall or defined by the edge of a solid radionuclide sphere."

<i>Claim Language</i>	<i>Court's Construction</i>
"inner spatial volume"	a region of space surrounded by an outer spatial volume and either enclosed by a polymeric film wall or defined by the outside surface of a solid radionuclide sphere

"Outer, closed, inflatable chamber"

<i>Cytac's proposed construction</i>	<i>Xoft's proposed construction</i>
(no construction required)	Inflatable balloon, i.e., deflated balloon

Part (c) of claim 1 explains that the "outer, closed, inflatable chamber" is "defined by a radiation transparent wall affixed to the body member proximate the distal end thereof in surrounding relation to the inner spatial volume with a predetermined constant spacing between said inner spatial volume and the radiation transparent wall." '813 patent, col. 4, ll. 40-45. The preferred embodiment recites a similar structure: "Surrounding the spatial volume **30** is an outer chamber **34** defined by an outer polymeric film wall **36** that is appropriately spaced from the wall **32** of the inner chamber **30** when the two chambers are inflated or otherwise filled and supported." '813 patent, col. 2, ll. 37-41. There is no support in the patent for Xoft's argument that "outer, closed, inflatable chamber" should be limited to only a balloon in a deflated state. The

court will therefore adopt Cytyc's proposal and not otherwise define this term.

<i>Claim Language</i>	<i>Court's Construction</i>
"outer, closed, inflatable chamber"	outer, closed, inflatable chamber

"Predetermined constant spacing"

<i>Cytyc's proposed construction</i>	<i>Xoft's proposed construction</i>
(no construction required)	(indefinite)

"Predetermined constant spacing between said inner spatial volume and radiation transparent wall"

<i>Cytyc's proposed construction</i>	<i>Xoft's proposed construction</i>
	(indefinite)

The spacing between the inner spatial volume and the radiation transparent wall of the outer, closed, inflatable chamber, when inflated, can be made constant in all directions if the outer chamber is spherical, or constant along a radial plane if the outer chamber is not spherical

Xoft argues that the '813 patent is indefinite because it does not disclose how one "predetermines" the amount of spacing. Xoft points out that the spacing between the edges of the inner and outer volumes may change as parts of the apparatus are inflated or deflated, so the spacing is not constant. Cytyc's expert explained that "predetermined constant spacing" means that "the spacing between the inner spatial volume and the wall of the outer inflatable chamber can be made constant in all directions if the outer chamber is spherical, or constant along a radial direction if non-spherical, whenever the outer chamber is inflated." Su Decl. (dkt.# 49), Ex. D (Verhey Decl.) at 7 (citations omitted). Cytyc also argues that "[o]ne skilled in the art knows how to determine an appropriate 'predetermined constant spacing' and Xoft provides no evidence, testimony, or case law to the contrary. Xoft cannot possibly show that the term is indefinite by clear and convincing evidence." Reply Br. (dkt. # 53) at 15.

Because 35 U.S.C. s. 282 gives a patent "a statutory presumption of validity," a challenger bears the burden of proving "by clear and convincing evidence" that a patent is invalid. *Monsanto Co. v. Scruggs*, 459 F.3d 1328, 1336-37 (Fed.Cir.2006). "[P]atent documents need not include subject matter that is known in the field of the invention." *S3 Inc. v. NVIDIA Corp.*, 259 F.3d 1364, 1371 (Fed.Cir.2001). From the testimony of Dr. Verhey, it appears that one skilled in the art would know how to "predetermine" the amount of spacing.FN5 *See* Tr. at 56-61, 85-89. Xoft offered no evidence suggesting otherwise. As the burden of proof is Xoft's, its indefiniteness argument necessarily fails given the absence of supporting evidence. The court will therefore adopt Cytyc's proposed construction of "predetermined constant spacing between said inner spatial volume and radiation transparent wall" modified only to make the definition easier to understand. A separate construction for "predetermined constant spacing" is not necessary.

<i>Claim Language</i>	<i>Court's Construction</i>
"predetermined constant spacing"	(no construction necessary)

"predetermined constant spacing between said inner spatial volume and radiation transparent wall" spacing predetermined by one skilled in the art between the wall or edge of the inner spatial volume and the radiation transparent wall of the outer, closed, inflatable chamber, when inflated, which is constant in all directions if the outer chamber is spherical, or constant along a radial plane if the outer chamber is not spherical

"Rendering uniform"

<i>Cytec's proposed construction</i>	<i>Xoft's proposed construction</i>
(no construction required)	Making the same, i.e., causing to have the same value or characteristic at all points.

"Means ... for rendering uniform the radial absorbed dose profile of the emissions"

<i>Cytec's proposed construction</i>	<i>Xoft's proposed construction</i>
Function: Modifying the ratio of the absorbed dose at a depth of interest in the target tissue to the absorbed dose at the surface of the tissue.	Function: Making the dose along a radius extending from the radionuclide outwardly from the outer chamber wall the same at every point on the radius.
Structure: A radiation absorbing or attenuating material, e.g., air, x-ray contrast fluid, contrast media used in angiography, water, a gas, or barium sulfate.	Structure: No such means disclosed in '813 patent, means for making more uniform disclosed as substance within outer chamber.

Xoft's argument is that "uniform" must be taken literally, and the apparatus must produce radiation that does not decrease in strength with increasing distance from the source.FN6 The parties do not dispute that Xoft's construction would require a physical impossibility; the strength of radiation necessarily decreases with distance from its source. Xoft, however, seeks to interpret "uniform" in a vacuum. The meaning of a particular word in a claim must be interpreted in light of the rest of the patent. *Ekchian v. Home Depot, Inc.*, 104 F.3d 1299, 1303 (Fed.Cir.1997).

While the patent could have been drafted with more clarity, it is readily apparent that the patentee did not contemplate absolute uniformity. Figure 4 of the patent (reproduced below) is a comparison between the distance versus radiation dose plots of two scenarios. Line **40** shows the radiation dose that would result if chamber **36** were filled with a radioactive fluid. '813 patent, col. 3, ll. 20-24. Line **42** shows the radiation dose that would result if, following the teachings of the patent, the same radioactive fluid were contained only in chamber **32**. '813 patent, col. 3, ll. 24-28. As explained in the patent, "Comparing the plots **40** and **42**, by providing the concentric arrangement depicted, the absorbed dose profile in the space between the 2 cm site and the wall of the outer balloon is maintained much more uniform, thus preventing over-treatment of body tissue at or close to the outer wall **36** of the instrument." '813 patent, col. 3, ll. 28-33.

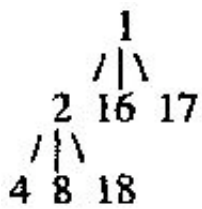

36

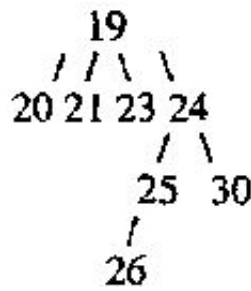

32

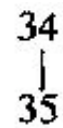

The patentee obviously did not expect absolute uniformity of radiation dosing. To interpret "uniform" in the manner urged by Xoft would go against the clear intent of the patentee. In *Bausch & Lomb, Inc. v. Barnes-Hind/Hydrocurve, Inc.*, 796 F.2d 443 (Fed.Cir.1986), the defendant made a similar argument regarding the patentee's use of the term "smooth" with respect to the edges of contact lenses. The Federal Circuit looked to the intrinsic evidence and found that "smooth" did not mean absolutely ridge free but rather that it meant "smooth enough to serve the inventor's purposes, *i.e.*, not to inflame or irritate the eyelid of the wearer or be perceived by him at all when in place." *Id.* at 450. In this case, the inventor's purpose was to deliver radiation more uniformly than had previously been done, "thus preventing over-treatment of body tissue at or close to the outer wall ... of the instrument." '813 patent, col. 3, ll. 28-32. The court will therefore define "rendering uniform" to mean to make the absorbed dose of radiation more uniform in order to prevent over-treatment of body tissue at or close to the outer wall of the instrument.

Since limitation language "means ... for rendering uniform the radial absorbed dose profile of the emissions" is in means-plus-function format, the function must be construed and the corresponding structure or its equivalent identified in the specification. *BBA Nonwovens Simpsonville, Inc. v. Superior Nonwovens, L.C.C.*, 303 F.3d 1332, 1343 (Fed.Cir.2002). As discussed, Xoft's definition of the function requires absolute uniformity which is not possible and which is not what the patent requires or the inventor intended. Cytyc's proposed definition construes the function as "modifying the ratio of the absorbed dose at a depth of interest in the target tissue to the absorbed dose at the surface tissue." Although this appears to be a function of the invention, Cytyc's definition is too broad because it encompasses absorbed doses at the surface tissue that are not substantially uniform to absorbed doses at the target tissue. In other words, Cytyc's definition would not only encompass the radiation dose profile of line 42 above, but would also encompass the radiation dose profile of line 40. Furthermore, all radiation dose profiles between line 40 and line 42 that result in over-treatment of the surface tissue would also be included under Cytyc's definition. A more accurate construction of the function would require the absorbed dose at the target tissue and the absorbed dose at the surface tissue to be more uniform to prevent over-treatment of the surface tissue. Thus, the court defines the function of the "means ... for rendering uniform the radial absorbed dose profile of the emissions" as making the absorbed dose of radiation more uniform to prevent over-treatment of body tissue at or close to the outer wall of the instrument.

Cytyc also identifies a radiation-absorbing or -attenuating material as the corresponding structure. At the claim construction hearing, Xoft argued that the uniformity of the radiation dose curve is solely affected by distance from the radiation source; the parties agree that this is true. *See Tr.* at 60-61. Although the composition of the material is not critical to the function, the radiation-absorbing or -attenuating material provides the distance necessary for achieving the uniformity in radiation dose curve. Thus, the court construes the language consistently with Cytyc's position.

Claim Language	Court's Construction
----------------	----------------------

"rendering uniform"	to make the absorbed dose of radiation more uniform to prevent over-treatment of body tissue at or close to the outer wall of the instrument
---------------------	--

"Means ... for rendering uniform the radial absorbed dose profile of the emissions"

Function: Making the absorbed dose of radiation more uniform to prevent over-treatment of body tissue at or close to the outer wall of the instrument.

Structure: A radiation absorbing or attenuating material, *e.g.*, air, x-ray contrast fluid, contrast media used in angiography, water, a gas, or barium sulfate or their equivalents.

"The radioactive material"

<i>Cytec's proposed construction</i>	<i>Xoft's proposed construction</i>
--------------------------------------	-------------------------------------

The material of claim 1 containing a radionuclide. (indefinite)

Claim 8 of the patent covers "[t]he apparatus as in claim 2 wherein the inner chamber contains the radioactive material." Claim 2 depends from claim 1. The parties dispute whether "a material containing a radionuclide(s)" suffices as an antecedent basis for "the radioactive material." It is readily apparent that the "radioactive material" in claim 8 refers back to "a material containing a radionuclide" described in claim 1, since "radionuclide" is the only radioactive material mentioned in claim 1. Anyone skilled in the art would so conclude. Xoft's contention that the term "radioactive material" is indefinite because it contains no antecedent basis is without merit. Xoft offers no authority suggesting that the antecedent basis of a term used in a dependent claim must be stated in identical words.FN7 The court, therefore construes "the radioactive material" in claim 8 to be the "radionuclide(s)" referred to in claim 1.

<i>Claim Language</i>	<i>Court's Construction</i>
-----------------------	-----------------------------

"The radioactive material"	The material of claim 1 containing a radionuclide.
----------------------------	--

"A plurality of radioactive solid particles placed at predetermined locations within the inner spatial volume to provide a desired composite radiation profile"

<i>Cytec's proposed construction</i>	<i>Xoft's proposed construction</i>
--------------------------------------	-------------------------------------

A plurality of radioactive solid particles placed at predetermined locations within the inner spatial volume to provide a desired dose profile that is the sum of the radiation profiles of the plurality of particles.

Static array of solid radioactive particles each placed in a single location and mounted on distal ends of separate wires. Desired composite radiation profile" is indefinite.

Claim 12 of the patent is directed to "[t]he apparatus as in claim 1 wherein the material containing a radionuclide comprises a plurality of radioactive solid particles placed at predetermined locations within the inner spatial volume to provide a desired composite radiation profile." Xoft argues claim 12 is indefinite on two grounds: first, that "desired composite radiation profile" is not defined, and second, that "inner spatial volume" is indefinite because no physical structure bounds it. The court rejects Xoft's second argument for the reasons given when construing "inner spatial volume" above. The court rejects Xoft's first argument because it presents no evidence that one skilled in the art would not understand "desired composite radiation

profile." FN8 Cytac's proposed construction does not clarify the meaning of claim 12. However, since the language is understandable as is, no construction of "a plurality of radioactive solid particles placed at predetermined locations within the inner spatial volume to provide a desired composite radiation profile" is necessary or appropriate.

<i>Claim Language</i>	<i>Court's Construction</i>
"A plurality of radioactive solid particles placed at predetermined locations within the inner spatial volume to provide a desired composite radiation profile"	(no construction needed)

B. Terms of the '204 patent

Claim 1 of the '204 patent is similar to claim 1 of the '813 patent. Claim 1 of the '204 patent describes: An interstitial brachytherapy apparatus for delivering radioactive emissions to an internal body location comprising:

- (a) a catheter body member having a proximal end and distal end;
- (b) an inner spatial volume disposed proximate to the distal end of the catheter body member;
- (c) an outer spatial volume defined by an expandable surface element disposed proximate to the distal end of the body member in a surrounding relation to the inner spatial volume; and
- (d) a radiation source disposed in the inner spatial volume and generating a three-dimensional isodose profile that is substantially similar in shape to the expandable surface element.

"Interstitial"

<i>Cytac's proposed construction</i>	<i>Xoft's proposed construction</i>
(no construction required)	Site in natural or surgically created cavity in body.

"Brachytherapy"

<i>Cytac's proposed construction</i>	<i>Xoft's proposed construction</i>
Radiation therapy delivered by a spatially confined radiation source at or near the site of the diseased tissue.	Radiation therapy delivered by a spatially confined radionuclide at or near a tumor or other proliferative tissue disease site.

"Interstitial brachytherapy"

<i>Cytac's proposed construction</i>	<i>Xoft's proposed construction</i>
Brachytherapy applied directly to the interspaces of a body tissue, where the interspaces are not naturally occurring.	Radiation therapy delivered by a spatially confined radionuclide at or near a tumor site in a natural or surgically created cavity in a body.

Cytc argues that "interstitial" and "brachytherapy" should be constructed together; Xoft seeks a separate construction for each word. Cytc also complains that Xoft seeks to limit "brachytherapy" to radionuclides, arguing that the definition should encompass any radiation source. However, the patent provides a clear definition of "brachytherapy": "The term 'brachytherapy,' as used herein, refers to radiation therapy delivered by a spatially confined radioactive material inserted into the body at or near a tumor or other proliferative tissue disease site." '204 patent, col. 1, ll. 30-33. Here, the patentee clearly acted as his own lexicographer, and Cytc's arguments for a broader definition do not acknowledge this clear definition. The court construes "brachytherapy" to mean "radiation therapy delivered by a spatially-confined radioactive material inserted into the body at or near a tumor or other proliferative tissue disease site." FN9

Xoft argues that "interstitial" means any body cavity, while Cytc argues that "interstitial" should be limited to only non-naturally-occurring cavities. As Xoft points out, one medical dictionary defines "interstitial" as "1. Placed or lying between. 2. Pert. to interstices or spaces within an organ or tissue." TABER'S CYCLOPEDIA MEDICAL DICTIONARY, 1007 (Clayton M. Thomas, ed., 17th ed.1993). Although not cited by the parties, a British oncology text indicates that "interstitial" has a particular meaning in the field of the invention:

Two main techniques are used for the delivery of radiation which is given either as an external beam or as short range radiation from an implanted radioactive source. External beam radiation usually involves megavoltage produced by linear accelerator as photons or electrons or from cobalt sources in the form of relative low energy X-rays or gamma rays. The latter are often used to treat relatively superficial lesions such as basal cell carcinoma or recurrences within the skin. High energy radiation can be used to treat deeply located lesions such as prostatic carcinomas without delivering an excessive dose to adjacent normal tissue....

Interstitial implant irradiation gives a high local dose to the tumour and usually employs sources such as radium, iridium, or caesium used in the form of needles or wires implanted in the tumour. This technique is widely used in the treatment of head and neck cancers to deliver a high tumour dose without irradiation to sensitive organs such as the lens of the eye or the spinal cord.

I.S. Fentiman, *The local Treatment of Cancer*, INTRODUCTION TO THE CELLULAR & MOLECULAR BIOLOGY OF CANCER, 434, 446 (L.M. Franks & N.M. Teich, eds., 2d ed.1991).

However, Cytc points out that regardless of any generally-accepted meaning of "interstitial" in the field of the invention, the patentee limited "interstitial" during prosecution to refer to only surgically-created cavities (and similarly defined "intercavitary" to refer to natural body cavities):

Turning to the cited prior art, the Ishiwara device comprises a thermotherapeutic apparatus having a catheter body member, an inner lumen surrounded by an outer lumen, and a radiation source contained within the inner lumen.... Ishiwara's apparatus is inserted into a body cavity. Hence, the apparatus does not provide *interstitial* radiation treatment, as Applicant's invention requires, but rather intercavitary radiation treatment.

Su Decl. (dkt.# 49), Ex. C (Amendment & Resp.) at 11 (citations omitted). This is consistent with the background section of the patent, which mentions surgical cavities several times but not natural ones. '204 patent, col. 1, ll. 19, 23, 25, 63, col. 2, l. 1. Also, although the summary section does not specify what type of cavities the apparatus claims are directed to, the summary makes clear that the method claims are directed

to a method that "includes surgically creating access to the proliferating tissue within a patient and surgically resecting at least a portion of the proliferating tissue to create a resection cavity within body tissue ." Id., col. 3, ll. 3-6.

The parties did not brief the issue of how much weight the court should afford the prosecution history in this instance.FN10 The Federal Circuit has instructed that "[a]lthough prosecution history can be a useful tool for interpreting claim terms, it cannot be used to limit the scope of a claim unless the applicant took a position before the PTO that would lead a competitor to believe that the applicant had disavowed coverage of the relevant subject matter." *Schwing GmbH v. Putzmeister Aktiengesellschaft*, 305 F.3d 1318, 1324 (Fed.Cir.2002). Here, the patentee clearly disavowed coverage of intercavitary radiation treatment when arguing to the PTO. Given the intrinsic evidence is of primary importance FN11 and all supports Cytyc's position, the court construes "interstitial" to mean "involving a surgically-created cavity in a body."

In light of the constructions of "interstitial" and "brachytherapy" above, no further construction of "interstitial brachytherapy" is necessary.

<i>Claim Language</i>	<i>Court's Construction</i>
"interstitial"	involving a surgically-created cavity in a body
"brachytherapy"	radiation therapy delivered by a spatially-confined radioactive material inserted into the body at or near a tumor or other proliferative tissue disease site

"interstitial
brachytherapy" (no construction necessary)

"Inner spatial volume"

<i>Cytyc's proposed construction</i>	<i>Xoft's proposed construction</i>
A region of space surrounded by an outer spatial volume that is defined by an expandable surface element	Inner balloon in two-balloon device or spherical solid radionuclide in one-balloon device.

The phrase "inner spatial volume" appears in both patents-in-suit. The parties' arguments regarding the meaning of "inner spatial volume" are similar for each patent. The relevant portions of the specification are the same, and, additionally, the '204 patent purports to incorporate by reference the '813 patent. '204 patent, col. 1, ll. 10-11. The court will therefore construe "inner spatial volume" in the '204 patent in the same manner as for the ' 813 patent.

<i>Claim Language</i>	<i>Court's Construction</i>
"inner spatial volume"	a region of space surrounded by an outer spatial volume and either enclosed by a polymeric film wall or defined by the outside surface of a solid radionuclide sphere.

"Outer spatial volume"

<i>Cytyc's proposed construction</i>	<i>Xoft's proposed construction</i>
(no construction required)	Balloon or cage.

or

A region of space defined by an expandable surface element and surrounding an inner spatial volume.

The phrase "outer spatial volume" in the '204 patent is analogous to the "outer, closed, inflatable chamber" of the '813 patent. The "outer spatial volume" is also explained in a similar manner; it is "defined by an expandable surface element disposed proximate to the distal end of the body member in a surrounding relation to the inner spatial volume." '204 patent, col. 8, ll. 22-25. Xoft again confuses the concepts of a volume with the boundary of a volume. Cytyc's proposed construction is congruent with the language of claim 1 of the '204 patent, so the court will construe "outer spatial volume" as "a region of space defined by an expandable surface element and surrounding an inner spatial volume."

<i>Claim Language</i>	<i>Court's Construction</i>
"outer spatial volume"	a region of space defined by an expandable surface element and surrounding an inner spatial volume

"Expandable surface element"

<i>Cytyc's proposed construction</i>	<i>Xoft's proposed construction</i>
(no construction required)	Deflated balloon or collapsed cage.

or

A device that can be expanded or inflated, such as an expandable cage or an inflatable balloon.

Xoft's basic argument is that "expandable surface element" must be a deflated structure because once something is fully inflated, it is no longer expandable. Xoft also points out that part (d) of claim 1 refers to the "isodose profile" being "substantially similar in shape to the expandable surface element" without specifying whether the expandable surface element is fully expanded. It is apparent that the patentee intended "expandable surface element" to refer to a structure whether it was fully inflated or not. Xoft's proposed construction would have this element wink out of existence at full inflation, leaving the "outer spatial volume" unbounded and giving the "isodose profile" no shape. The court agrees with Cytyc that no construction of the term is necessary.

<i>Claim Language</i>	<i>Court's Construction</i>
"expandable surface element"	(no construction needed)

"Radiation source"

<i>Cytyc's proposed construction</i>	<i>Xoft's proposed construction</i>
(no construction required)	radionuclide

The patent provides a clear definition of "brachytherapy": "The term 'brachytherapy,' as used herein, refers

to radiation therapy delivered by a spatially confined radioactive material inserted into the body at or near a tumor or other proliferative tissue disease site." All asserted independent claims of the '204 patent contain the phrase "interstitial brachytherapy," which the court has construed as "radiation therapy delivered by a spatially-confined radioactive material inserted into the body at or near a tumor or other proliferative tissue disease site." Cytac's argument that "radiation source" should not be constructed to exclude any radiation sources must be rejected; the claims clearly do not contemplate a radiation source other than "radioactive material."

There is still, however, the question of whether "radioactive material" means the same thing as Xofter's proposed construction of "radionuclide." FN12 In describing the preferred embodiment, the patent says: "[t]he inner volume 30 is then filled with a material containing a predetermined radionuclide, for example, I-125, I-131, Yb-169 or other source of radiation, such as radionuclides that emit photons, beta particles, gamma radiation, or other therapeutic rays." '204 patent, col. 4, ll. 9-13 (emphasis added). Since all the examples of sources of radiation given in the specification are radionuclides, the patentee appears to have intended to define "radioactive material" as "radionuclides." Cytac argued at the *Markman* hearing that "or other therapeutic rays" could refer to other sources such as x-rays. The words "or other therapeutic rays," however, clearly refers to types of radionuclides. Cytac's construction would require the patentee to have inserted the word "or" before "gamma radiation," indicating the end of the list of types of radionuclides.FN13

Dictionary definitions are consistent with construing "radiation source" as a "radionuclide." One definition of "radioactive" is "[a] descriptive term for a material made up of atoms in which radioactivity occurs." AMERICAN HERITAGE NEW DICTIONARY OF CULTURAL LITERACY (3d ed.2006). A medical dictionary provided by Xofter defines "radioactive" as "giving off radiation as the result of the disintegration of the nucleus of an atom." MOSBY'S MEDICAL, NURSING, AND ALLIED HEALTH DICTIONARY, 1326 (Kenneth N. Anderson *et al.* eds., 4th ed.1994). Cytac has not presented evidence that one skilled in this art would understand "radioactive material" any differently. The court agrees with Xofter-the term "radioactive" in the context of the '204 patent does not encompass such radiation sources as x-ray tubes, and "radiation source" therefore should be taken to mean "radionuclide."

<i>Claim Language</i>	<i>Court's Construction</i>
"radiation source"	radionuclide

"Minimum prescribed dose"

<i>Cytac's proposed construction</i>	<i>Xofter's proposed construction</i>
Minimum prescribed dose received within a target tissue for delivering therapeutic effects.	Minimum dose needed to treat cancer cells.

The parties have requested construction of the phrase "minimum prescribed dose" and point out that the term appears in claims 2, 18, 24, 32, and 36 of the '204 patent. The parties do not argue that the term should be construed differently for different claims. However, claims 2, 24, 32, and 36 contain the phrase "minimum prescribed absorbed dose," and claim 18 contains the phrase "prescribed absorbed dose." These inconsistencies seem irrelevant, however, because the parties' dispute is whether any such doses should be limited to treatment of cancer cells or allowed to cover any potential therapeutic effects. The court's

construction of "brachytherapy" limits the claims to treatments "at or near a tumor or other proliferative tissue disease site." Xoft's proposed construction is too narrow, and Cytyc's is too broad. However, in light of the construction of "brachytherapy," no construction of "minimum prescribed dose" or similar phrases is necessary.

<i>Claim Language</i>	<i>Court's Construction</i>
"minimum prescribed dose"	(no construction necessary)

"Delivering a prescribed absorbed dose"

<i>Cytyc's proposed construction</i>	<i>Xoft's proposed construction</i>
(no construction required)	(indefinite)

Xoft argues that the patent does not reveal how one goes about prescribing a dose using the device, and that the phrase "delivering a prescribed absorbed dose" is therefore fatally indefinite. The '204 patent, however, describes a tool for treating proliferative tissue disease. A patent could adequately describe and claim a new apparatus or method for making the corrective curves in contact lenses, but a description of the particular curves a patient might require would not be necessary. If those skilled in the art would know how to use the disclosed invention, describing how to use it is unnecessary-the patentee merely needs to adequately describe the invention. Since Xoft bears the burden of proving that those skilled in the art would not know how to use the tool or method described in the patent and has presented no evidence on the subject, the court rejects Xoft's contention that the phrase is indefinite. No construction is necessary.

<i>Claim Language</i>	<i>Court's Construction</i>
"delivering a prescribed absorbed dose"	(no construction necessary)

"The inner and outer spatial volumes are configured to provide a minimum prescribed absorbed dose"

<i>Cytyc's proposed construction</i>	<i>Xoft's proposed construction</i>
The inner and outer spatial volumes are configured to provide a minimum prescribed absorbed dose for delivering	(indefinite)

"The inner and outer spatial volumes are configured to provide a minimum prescribed absorbed dose"

<i>Cytyc's proposed construction</i>	<i>Xoft's proposed construction</i>
Configuring the inner and outer spatial volumes to provide a minimum prescribed absorbed dose for delivering therapeutic effects to a target tissue.	(indefinite)

The phrases "the inner and outer spatial volumes are configured to provide a minimum prescribed absorbed dose" and "configuring the inner and outer spatial volumes to provide a minimum prescribed absorbed dose" are not indefinite for essentially the same reasons given in the previous section. As Cytac again appears to be attempting to impermissibly broaden its claims to capture any therapeutic effect, despite the clear limitation provided by the patentee's definition of "brachytherapy," the court also cannot adopt Cytac's proposed construction. No construction of the disputed language is necessary in light of the court's construction of other terms in the patent.

<i>Claim Language</i>	<i>Court's Construction</i>
"the inner and outer spatial volumes are configured to provide a minimum prescribed absorbed dose"	(no construction necessary)
"the inner and outer spatial volumes are configured to provide a minimum prescribed absorbed dose"	(no construction necessary)

"A minimum distance outward from the outer spatial volume expandable surface"

<i>Cytac's proposed construction</i>	<i>Xoft's proposed construction</i>
(no construction required)	(indefinite)

Claims 2, 24, 32, and 36 all include the phrase "the target tissue being defined between the outer spatial volume expandable surface and a minimum distance outward from the outer spatial volume expandable surface." FN14 Xoft asserts that "minimum distance" is indefinite in this context because the patent does not explain how the minimum distance is determined.

Here, "minimum" does not appear to add anything to the patent. The "target tissue" is the tissue outside of the outer chamber for a fixed distance in all directions, but this fixed distance or how one determines it are not explained. It seems that one skilled in the art would know how to determine the distance. *See* Tr. at 85-89. But the patent may as well read "a short distance outward" or "a determined distance outward" or merely "a distance outward."

Cytac claims that specification provides some guidance and that the minimum distance may in some instances be between half and one centimeter. The specification does state that

device A can readily be configured to provide a dose in a therapeutic range, say between 40 to 60 Gray, at a distance between 0.5 and 1.0 cm from the outer spatial volume for an outer spatial volume having a diameter of 4.0 cm and being in contact with the resection cavity wall.

'204 patent, col. 6, ll. 31-35. However, Cytac neglects to mention that "device A" is "an interstitial brachytherapy apparatus ... such as those employed in U.S. Pat. No. 5,429,582, having a single spatial volume **50** filled with a radioactive material in solution." '204 patent, col. 6, ll. 3-7. In any case, this discussion does not use the phrases "target tissue" or "a minimum distance outward." Nevertheless, Xoft has presented no evidence that one skilled in the art would not understand the phrase "the target tissue being defined between the outer spatial volume expandable surface and a minimum distance outward from the

outer spatial volume expandable surface." Xoft has not met its burden of proving by clear and convincing evidence that this language is indefinite, and the court finds that no construction is necessary.

<i>Claim Language</i>	<i>Court's Construction</i>
"a minimum distance outward from the outer spatial volume expandable surface"	(no construction necessary)

"Controlled dose"

<i>Cytc's proposed construction</i>	<i>Xoft's proposed construction</i>
(no construction required)	(indefinite)

"To reduce or prevent necrosis in healthy tissue proximate to the expandable surface"

<i>Cytc's proposed construction</i>	<i>Xoft's proposed construction</i>
(no construction required)	(indefinite)

"Providing a controlled dose at the outer spatial volume expandable surface to reduce or prevent necrosis in healthy tissue"

<i>Cytc's proposed construction</i>	<i>Xoft's proposed construction</i>
Controlling the ratio of the dose at the expandable surface of the outer spatial volume to the prescribed dose at the depth of interest in the target issue so that the dose at the expandable surface is not so high that it lethally damages cells in healthy tissue in contact with the expandable surface	(indefinite)

Xoft argues that the patent does not reveal how one goes about controlling a dose using the device and that "reducing necrosis" is a hopelessly vague concept, making the '204 patent indefinite. Xoft, however, has presented no evidence that one skilled in the art would not be able to understand the patent and has again failed to meet its burden of proof. The court will therefore adopt Cytc's construction proposals. "Providing a controlled dose at the outer spatial volume expandable surface to reduce or prevent necrosis in healthy tissue" means "controlling the ratio of the dose at the expandable surface of the outer spatial volume to the prescribed dose at the depth of interest in the target issue so that the dose at the expandable surface is not so high that it lethally damages cells in healthy tissue in contact with the expandable surface."

<i>Claim Language</i>	<i>Court's Construction</i>
"controlled dose"	(no separate construction necessary)
"to reduce or prevent necrosis in healthy tissue proximate to the expandable surface"	(no separate construction necessary)

"providing a controlled dose at the outer spatial volume expandable surface to reduce or prevent necrosis in healthy tissue" controlling the ratio of the dose at the expandable surface of the outer spatial volume to the prescribed dose at the depth of interest in the target issue so that the dose at the expandable surface is not so high that it lethally damages cells in healthy tissue in contact with the expandable surface

"Adapting the expandable surface to contact tissue surrounding the resection cavity to conform the tissue"

<i>Cytec's proposed construction</i>	<i>Xoft's proposed construction</i>
(no construction required)	(indefinite)

Xoft's contention that this phrase is indefinite springs from its argument that "expandable surface element" means "deflated balloon or cage." As the court has rejected Xoft's interpretation of "expandable surface element," no construction of "adapting the expandable surface to contact tissue surrounding the resection cavity to conform the tissue" is necessary.

<i>Claim Language</i>	<i>Court's Construction</i>
"adapting the expandable surface to contact tissue surrounding the resection cavity to conform the tissue"	(no construction necessary)

"Desired shape of the expandable surface element"

<i>Cytec's proposed construction</i>	<i>Xoft's proposed construction</i>
(no construction required)	(indefinite)

Xoft has again presented no evidence to back up an argument that the phrase is indefinite and therefore again fails to carry its burden of proof. No construction of "desired shape of the expandable surface element" is necessary.

<i>Claim Language</i>	<i>Court's Construction</i>
"desired shape of the expandable surface element"	(no construction necessary)

"Predetermined spacing"

<i>Cytec's proposed construction</i>	<i>Xoft's proposed construction</i>
(no construction required)	(indefinite)

"A predetermined spacing is provided between said inner spatial volume and the expandable surface element" / "A predetermined spacing between said inner spatial volume and the expandable surface element"

<i>Cytec's proposed construction</i>	<i>Xoft's proposed construction</i>
The distance between the inner spatial volume and the expandable surface element is determined in advance	(indefinite)

Xoft's contention that these phrases are indefinite is based on its argument that "expandable surface element" means "deflated balloon or cage," and Xoft has again presented no evidence to back up arguments that the phrases are indefinite. No construction of "predetermined spacing" is necessary. The court will adopt Cytec's proposals and define both of the long phrases ("a predetermined spacing is provided between said inner spatial volume and the expandable surface element" and "a predetermined spacing between said inner spatial volume and the expandable surface element") as "the distance between the inner spatial volume and the expandable surface element is determined in advance."

<i>Claim Language</i>	<i>Court's Construction</i>
"predetermined spacing"	(no construction necessary)
"a predetermined spacing is provided between said inner spatial volume and the expandable surface element" / "a predetermined spacing between said inner spatial volume and the expandable surface element"	the distance between the inner spatial volume and the expandable surface element is determined in advance

"Intraoperatively"

<i>Cytec's proposed construction</i>	<i>Xoft's proposed construction</i>
(no construction required)	After surgical removal of tumor but prior to closing the surgical site
<i>or</i>	
During the surgical operation to remove proliferative tissue.	

At the claim construction hearing, the parties appeared to agree on the definition of "interoperatively." *See* Tr. at 140. The previous apparent disagreement revolved around whether the surgical site could be closed before insertion of the catheter apparatus. The court understands that the parties agree that the catheter must be inserted before the surgical site is closed. The '204 patent at column 7, lines 55-64, specifically refers to the catheter being inserted "[f]ollowing tumor resection, but prior to closing the surgical site."

<i>Claim Language</i>	<i>Court's Construction</i>
"intraoperatively"	following tumor resection, but prior to closing the surgical site

"Solid radiation source"

<i>Cytec's proposed construction</i>	<i>Xoft's proposed</i>

A radiation source that has a fixed shape and volume, and is not deformable Solid radionuclide

The parties' primary dispute here is whether "radiation source" encompasses more than radionuclides, which the court addressed above to limit "radiation source" to radionuclides. Cytyc presents a dictionary definition of "solid," namely, "of definite shape and volume; not liquid or gaseous," from the AMERICAN HERITAGE COLLEGE DICTIONARY, 1295 (3d ed.1997). The court will therefore define "solid radiation source" as "a radionuclide of definite shape and volume; not liquid or gaseous."

<i>Claim Language</i>	<i>Court's Construction</i>
"solid radiation source"	a radionuclide of definite shape and volume; not liquid or gaseous

"The prescribed absorbed dose is delivered to the target tissue in substantially three dimensions"

<i>Cytyc's proposed construction</i>	<i>Xoft's proposed construction</i>
The prescribed absorbed dose is delivered to the target tissue such that all points at a given outward distance from the tissue wall will receive the same dose.	(indefinite)

Xoft contends that "prescribed absorbed dose" and "in substantially three dimensions" render "the prescribed absorbed dose is delivered to the target tissue in substantially three dimensions" fatally indefinite. The court has already rejected Xoft's argument regarding "prescribed absorbed dose."

Xoft points to Cytyc's expert's testimony that "there's no such thing as substantially three dimensions" because something is either three dimensional or not. Mulville Decl. (dkt.# 51), Ex. L (Verhey Decl.) at 153. Cytyc points to Xoft's expert's testimony that he could envision a brachytherapy apparatus that delivered 99 percent of its radiation in a plane; Cytyc claims such a flat radiation field would not be in substantially three dimensions. Though a closer question than some of Xoft's other indefiniteness contentions, the court nonetheless finds that Xoft has not shown by clear and convincing evidence that one skilled in the art would not understand "in substantially three dimensions" in the manner put forth by Cytyc. The court therefore adopts Cytyc's proposed construction for "the prescribed absorbed dose is delivered to the target tissue in substantially three dimensions," namely, "the prescribed absorbed dose is delivered to the target tissue such that all points at a given outward distance from the tissue wall will receive the same dose."

<i>Claim Language</i>	<i>Court's Construction</i>
"the prescribed absorbed dose is delivered to the target tissue in substantially three dimensions"	the prescribed absorbed dose is delivered to the target tissue such that all points at a given outward distance from the tissue wall will receive the same dose

III. ORDER

1. For the reasons given above, the court adopts the following claim construction as detailed in this order.

Term or phrase	Court's construction
"inner spatial volume"	a region of space surrounded by an outer spatial volume and

	either enclosed by a polymeric film wall or defined by the outside surface of a solid radionuclide sphere.
"outer, closed, inflatable chamber"	outer, closed, inflatable chamber
"predetermined constant spacing"	(no construction necessary)
"predetermined constant spacing between said inner spatial volume and radiation transparent wall"	spacing predetermined by one skilled in the art between the wall or edge of the inner spatial volume and the radiation transparent wall of the outer, closed, inflatable chamber, when inflated, which is constant in all directions if the outer chamber is spherical, or constant along a radial plane if the outer chamber is not spherical
"rendering uniform"	to make the absorbed dose of radiation more uniform to prevent over-treatment of body tissue at or close to the outer wall of the instrument

"Means ... for rendering uniform the radial absorbed dose profile of the emissions"
Function: Making the absorbed dose of radiation more uniform to prevent over-treatment of body tissue at or close to the outer wall of the instrument.

	Structure: A radiation absorbing or attenuating material, <i>e.g.</i> , air, x-ray contrast fluid, contrast media used in angiography, water, a gas, or barium sulfate or their equivalents.
"The radioactive material"	The material of claim 1 containing a radionuclide.
"A plurality of radioactive solid particles placed at predetermined locations within the inner spatial volume to provide a desired composite radiation profile"	(no construction needed)
"interstitial"	involving a surgically-created cavity in a body
"brachytherapy"	radiation therapy delivered by a spatially-confined radioactive material inserted into the body at or near a tumor or other proliferative tissue disease site
"interstitial brachytherapy"	(no construction necessary)
"outer spatial volume"	a region of space defined by an expandable surface element and surrounding an inner "expandable surface element" (no construction needed)
"radiation source"	radionuclide
"minimum prescribed dose"	(no construction necessary)
"delivering a prescribed absorbed dose"	(no construction necessary)
"the inner and outer spatial volumes are configured to provide a minimum prescribed absorbed dose"	(no construction necessary)
"the inner and outer spatial volumes are configured to provide a minimum prescribed absorbed dose"	(no construction necessary)
"a minimum distance outward from the outer spatial volume expandable surface"	(no construction necessary)
"controlled dose"	(no separate construction necessary)
"to reduce or prevent necrosis in healthy"	(no separate construction necessary)

tissue proximate to the expandable surface"	
"providing a controlled dose at the outer spatial volume expandable surface to reduce or prevent necrosis in healthy tissue"	controlling the ratio of the dose at the expandable surface of the outer spatial volume to the prescribed dose at the depth of interest in the target issue so that the dose at the expandable surface is not so high that it lethally damages cells in healthy tissue in contact with the expandable surface
"adapting the expandable surface to contact tissue surrounding the resection cavity to conform the tissue"	(no construction necessary)
"desired shape of the expandable surface element"	(no construction necessary)
"predetermined spacing"	(no construction necessary)
"a predetermined spacing is provided between said inner spatial volume and the expandable surface element" / "a predetermined spacing between said inner spatial volume and the expandable surface element"	the distance between the inner spatial volume and the expandable surface element is determined in advance
"intraoperatively"	following tumor resection, but prior to closing the surgical site
"solid radiation source"	a radionuclide of definite shape and volume; not liquid or gaseous

"the prescribed absorbed dose is delivered to the target tissue in substantially three dimensions"

the prescribed absorbed dose is delivered to the target tissue such that all points at a given outward distance from the tissue wall will receive the same dose

2. The parties shall appear for a further case management conference on June 1, 2007 at 10:30 a.m. and shall file a further joint case management conference statement no later than four days prior.

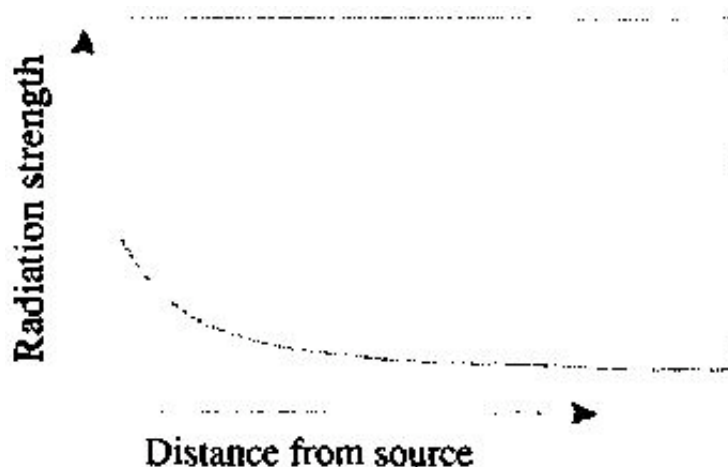

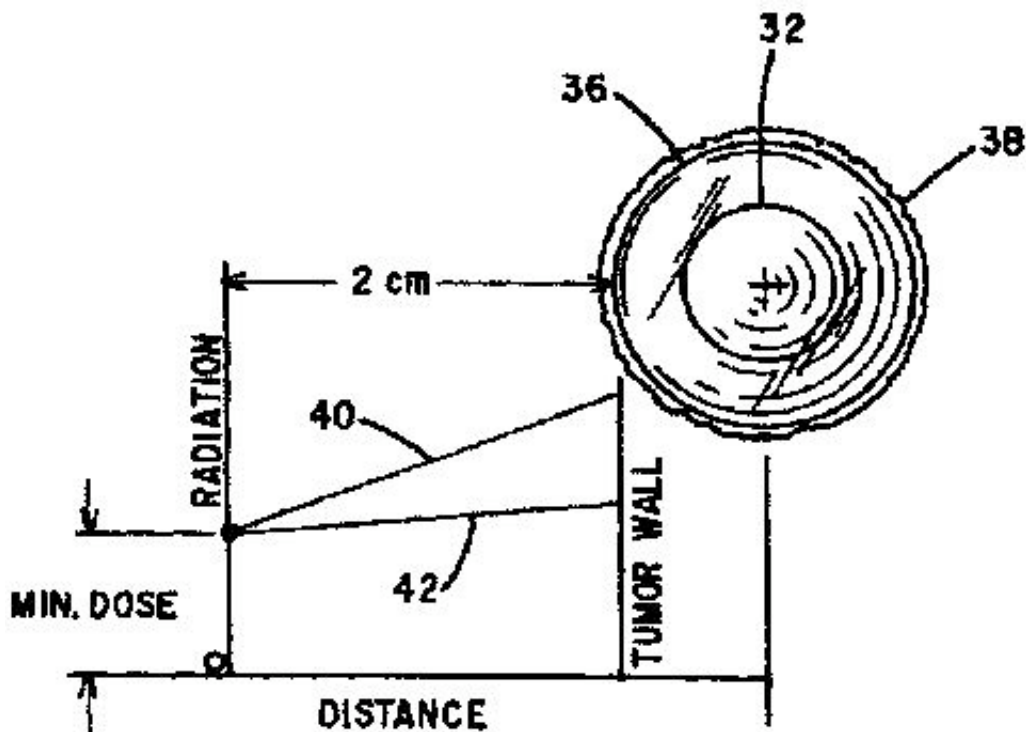

FN1. Cytoc asserts claims 1, 2, 3, 4, 8, and 12. Claim 1 is an apparatus claim and the only independent claim of the '813 patent. Claims 2, 3, and 12 depend directly from claim 1. Claim 4 depends from claim 3, and claim 8 depends from claim 2. The following is a graphic representation of the relationship of the asserted claims:

FN2. Cytoc asserts claims 1, 2, 3, 4, 8, 16, 17, 18, 19, 20, 21, 23, 24, 25, 26, 30, 32, 34, 35, and 36 of the '204 patent. Claims 1 and 36 are the only independent apparatus claims. From claim 1 depend claims 2, 16, and 17. From claim 2 depend claims 4, 8, and 18. Claims 19, 32, and 34 are independent method claims. Claims 20, 21, 23, and 24 all depend from claim 19. Claim 25 depends from claim 24, and claim 26 depends from claim 25. Claim 30 also depends from claim 24. Claim 35 depends from claim 34. The following is a graphic representation of the relationship of the asserted claims:

FN3. Presumably all occurrences of "spacial" in the '813 patent should be read as "spatial."

FN4. Presumably this "spatial volume" should be taken to be the first spatial volume, which would mean that the polymeric film wall forms the outer boundary of the second spatial volume and that the second spatial volume is of a uniform thickness on all sides of the first spatial volume. Such a reading would comport with claim 1(c).

FN5. Xoft argues that the size of the cavity determines the size of the apparatus when fully inflated, but this alone does not determine the spacing between the inner spatial volume and the wall of the outer chamber.

FN6. Xoft also stated that it would "submit a Motion for Summary Judgment on this issue prior to the conduct of the *Markman* hearing," Responsive Br. (dkt.# 50) at 14, but did not do so.

FN7. At the *Markman* hearing, Xoft stated that it would provide a citation to such supporting authority. Tr. at 64. Xoft, however, has not done so.

FN8. It would seem that for one skilled in the art, it would be a relatively simple matter to add up the individual radiation profiles of individual particles. *See* Tr. at 75-76.

FN9. This definition does not resolve the parties' dispute over whether "radioactive material" should be read to encompass only "radionuclides" (as Xoft wishes) or any "radiation source" (as Cytyc urges). As the parties have separately sought construction of "radioactive material," the court will address construction of that phrase below.

FN10. In its recent *en banc* explanation of the evidence to be used in construing claims, the Federal Circuit devoted a paragraph to prosecution history:

In addition to consulting the specification, we have held that a court "should also consider the patent's prosecution history, if it is in evidence." *Markman*, 52 F.3d at 980; *see also* *Graham v. John Deere Co.*, 383 U.S. 1, 33, 86 S.Ct. 684, 15 L.Ed.2d 545 (1966) ("[A]n invention is construed not only in the light of the claims, but also with reference to the file wrapper or prosecution history in the Patent Office."). The prosecution history, which we have designated as part of the "intrinsic evidence," consists of the complete record of the proceedings before the PTO and includes the prior art cited during the examination of the patent. *Autogiro*, 384 F.2d at 399. Like the specification, the prosecution history provides evidence of how the PTO and the inventor understood the patent. *See* *Lemelson v. Gen. Mills, Inc.*, 968 F.2d 1202, 1206 (Fed.Cir.1992). Furthermore, like the specification, the prosecution history was created by the patentee in attempting to explain and obtain the patent. Yet because the prosecution history represents an ongoing negotiation between the PTO and the applicant, rather than the final product of that negotiation, it often lacks the clarity of the specification and thus is less useful for claim construction purposes. *See* *Inverness Med. Switz. GmbH v. Warner Lambert Co.*, 309 F.3d 1373, 1380-82 (Fed.Cir.2002) (the ambiguity of the prosecution history made it less relevant to claim construction); *Athletic Alternatives, Inc. v. Prince Mfg., Inc.*, 73 F.3d 1573, 1580 (Fed.Cir.1996) (the ambiguity of the prosecution history made it "unhelpful as an interpretive resource" for claim construction). Nonetheless, the prosecution history can often inform the meaning of the claim language by demonstrating how the inventor understood the invention and whether the inventor limited the invention in the course of prosecution, making the claim scope narrower than it would otherwise be. *Vitronics*, 90 F.3d at 1582-83; *see also* *Chimie v. PPG Indus., Inc.*, 402 F.3d 1371, 1384 (Fed.Cir.2005) ("The purpose of consulting the prosecution history in construing a claim is to 'exclude any interpretation that was disclaimed during prosecution.'"), quoting *ZMI Corp. v. Cardiac Resuscitator Corp.*, 844 F.2d 1576, 1580 (Fed.Cir.1988); *Southwall Techs., Inc. v. Cardinal IG Co.*, 54 F.3d 1570, 1576 (Fed.Cir.1995).

Phillips v. AWH Corp., 415 F.3d 1303, 1317 (Fed.Cir.2005) (*en banc*).

FN11. The extrinsic evidence that Cytyc used "intercavitary" in literature and advertising in a manner that encompasses the definitions of "interstitial" and "intercavitary" it advances now, *see* Tr. at 93, is of little weight in this situation. Similarly, evidence presented by Cytyc that Xoft represented to the FDA that the term "interstitial" "is a more appropriate word for a cavity that is surgically created as compared to a natural body cavity," (*see* Decl. of Henry Su Supp. Cytyc's Supplemental Claim Construction Br., Ex. A, is not entitled to significant weight although it does suggest that one skilled in the art construes the term as Cytyc proposes.

FN12. The parties have agreed that "radionuclide" means "an isotope that undergoes radioactive decay."

FN13. Cytyc also stated that this was an "Oxford comma" issue. Tr. at 137-38. However, in the sentence at issue, the Oxford comma is the one after "gamma radiation." Whether it is present does not alter the meaning of the sentence. Cytyc also argued that "we're in the land of eats, shoots and leaves." If Cytyc was referring to a book of such title, the court does not see how that would support Cytyc's argument; the theme of *Eats, Shoots & Leaves* is that punctuation should be used correctly. *See* Lynne Truss, *Eats, Shoots & Leaves: The Zero Tolerance Approach to Punctuation* (2004).

FN14. The court believes that one skilled in the art would understand that the patentee intended to define "target tissue" as the tissue "between the outer spatial volume expandable surface and a minimum distance outward from the outer spatial volume expandable surface." Taken literally, the patent explains the physical location where the act of defining "target tissue" takes place.

N.D.Cal.,2007.

Xoft, Inc. v. Cytyc Corp.

Produced by Sans Paper, LLC.