

United States District Court,
E.D. Michigan, Southern Division.

HONEYWELL INTERNATIONAL, INC. and Honeywell Intellectual Properties, Inc,
Plaintiffs.

v.

**ITT INDUSTRIES, INC., ITT Automotive, Inc., TG North America Corporation, TG Fluid Systems
USA Corporation, and A. Raymond, Inc,**
Defendants.

Aug. 5, 2004.

Background: Owner of patent for motor vehicle fuel system component sued competitors for infringement.

Holding: Construing claims, the District Court, Cohn, J., held that "fuel injection system component," called for in patent, was limited to fuel filter embodiment described in specification.

Claims construed.

5,164,879. Construed.

Glenn E. Forbis, Kristin L. Murphy, R. Terrance Rader, Rader, Fishman, Bloomfield Hills, MI, for Plaintiffs
and Counter Defendants.

Amanda L. Conti Duhaime, Thomas N. Young, Young & Basile, Troy, MI, Stephen L. Sulzer, Lisa E.
Marks, Dickinson Wright, Washington, DC, Lawrence G. Campbell, Dickinson Wright, Detroit, MI,
Richard A. Jones, John B. Dolan, Dickinson Wright, Bloomfield Hills, MI, for Defendants and Counter
Claimants.

DECISION ON CLAIM CONSTRUCTION

COHN, District Judge.

Table of Contents

I.	Introduction	867
II.	Background	868
	A. General Background of the Invention	868
	B. The '879 Patent	868
	C. Claim 1	869
	D. The Problem	870

E.	Prosecution History of the '879 Patent	870
1.	The '920 Parent Patent Application: "Method"	871
2.	The '084 Divisional Patent Application: "Fuel Filter"	871
3.	The '879 Divisional Patent Application: "Moldable Material"	872
a.	Initial Examination	872
b.	Reexamination	874
III.	Claim Interpretation Generally	875
IV.	Analysis	877
A.	"Fuel Injection System Component for Communicating Fuel to the Engine of a Motor Vehicle"	878
1.	Ordinary Meaning of the Claim Language	878
2.	Specification	878
a.	Applicable Law	878
b.	Analysis	879
3.	Prosecution History	881
a.	Applicable Law	881
i.	<i>Biogen</i>	881
ii.	<i>Housey</i>	882
b.	Analysis	882
4.	Conclusion	883
B.	"Electrically Conductive Fibers"	883
C.	"A Conductive Member Leading to Said Electrical Plane"	885
D.	"Thereby Prevent the Build-up of Electrostatic Charge in the Fuel and the Resultant Arcing Which Causes the Breakdown of the Polymer Material Comprising the Fuel Injection System Component"	887
V.	Conclusion	887

I. Introduction

This is a patent case. Plaintiffs Honeywell International, Inc. and Honeywell Intellectual Properties, Inc. (collectively, Honeywell), holders of U.S. Patent No. 5,164,879 (the '879 patent) and Reexamination Certificate B1 5,164,879 covering an "Electrostatically Dissipative Fuel Filter," are suing defendants ITT Industries, Inc., ITT Automotive, Inc., TG North America Corporation, TG Fluid Systems USA Corporation, and A. Raymond, Inc. for infringement of the '879 patent. FN1 Claim 1 has been designated as the paradigm claim. FN2 Before the Court are the parties' papers relating to interpretation of the ambiguous terms in claim 1 of the '879 patent. The Court conducted a *Markman* hearing FN3 on May 25, 2004. The Court's findings are described below.

FN1. Specifically, Honeywell alleges in its complaint that defendants are infringing the '879 patent "by making, using, offering for sale, and selling fuel system components, including a fuel line connector with fibers, which provide an interface between the fuel system's fuel line hoses and/or other fuel system components."

FN2. *See* Letter by Counsel for Plaintiffs Regarding Identification of "Paradigm Claim" (November 6, 2003).

FN3. In *Markman v. Westview Instruments, Inc.*, 517 U.S. 370, 116 S.Ct. 1384, 134 L.Ed.2d 577 (1996), the United States Supreme Court made clear that claim construction is a question of law for the court. *Markman* and subsequent case law set forth the guidelines for claim construction. As such, a hearing on claim construction is known as a *Markman* proceeding. *See* James M. Amend, *Patent Law: A Primer for Federal District Judges* 15-18 (1998).

II. Background

A. General Background of the Invention

The fuel delivery system in a motor vehicle includes multiple working parts. Fuel stored in the fuel tank is pumped to the engine of the vehicle through fuel lines, which are typically made from plastic (such as Nylon-12) or steel tubing. A fuel filter is located between the tank and the engine to prevent dirt from getting inside the engine. The filter is usually a plastic or metal housing with a paper filter inside, which traps the dirt. The fuel system may also include other parts like connectors and pumps.

When fuel is pumped through a nonconductive plastic part, the friction between the flowing fuel and the plastic surface generates an electrostatic charge. Electrons are stripped from the fuel molecules and accumulate along the surface of the plastic because there is no path to ground. Naturally, the electrostatic charge build-up is greater when the fuel flows faster, such as in a fuel injection system (as contrasted with a carbureted system). When the electrostatic charge builds up to a sufficient level, it discharges by "arcing" FN4 to a nearby conductive surface like the metal vehicle body. Eventually, this arcing causes small holes to develop in the plastic, which can lead to a fuel leak and fire. The '879 patent is directed particularly to a solution for the arcing problem in a fuel filter.FN5

FN4. "Arcing" occurs when two charged objects are placed in close proximity to each other and the air between them becomes electrically charged, causing a spark to occur when the electric current jumps the gap.

FN5. As will be explained, Honeywell says that the '879 patent provides a solution for the arcing problem for all fuel injection system components, while defendants say that the '879 patent only covers fuel filters. As will be discussed, defendants are correct.

B. The '879 Patent

The ABSTRACT describes the invention as follows:

A fuel system component for a motor vehicle constructed from a polymer material to which are added stainless steel fibers to render the component electrically conductive while retaining moldability. The electrically conductive component permits charges generated by the fuel passing through the component to be dissipated to the vehicle body, thereby preventing arcing which causes erosion of the component and subsequent leaks.

Figure 1, the sole drawing in the patent, illustrates the invention:

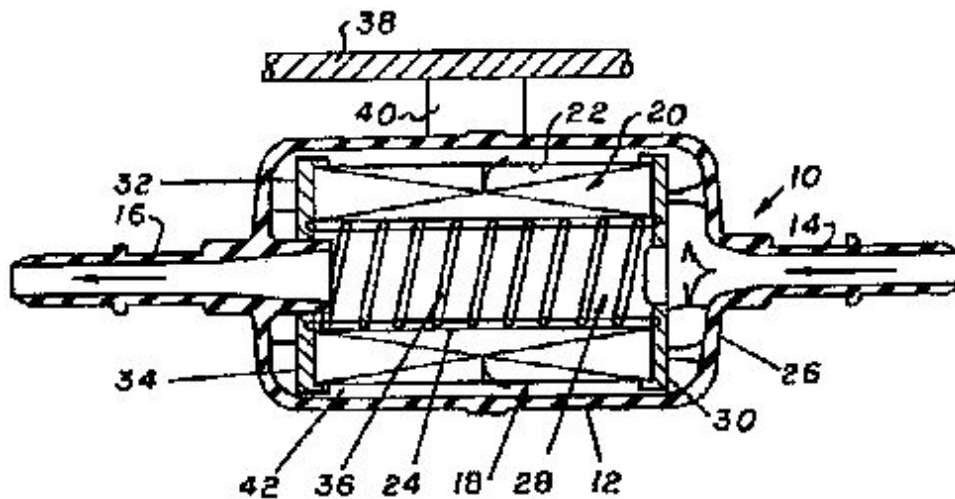

The specification generally describes the invention and the problem it solves as follows:

This invention relates to a fuel filter for use in the fuel line that delivers fuel to a motor vehicle engine.

The housings for filters used to filter the fuel delivered to a motor vehicle engine have commonly been made of metal or a polymer material, such as Nylon 12. Because of their inherently lower cost and other advantages, non-metallic fuel filters are preferred. Such non-metallic fuel filters have been commonly used on vehicles having carbureted engines without problems for many years. However, when such prior art non-metallic fuel filters were used on vehicles equipped with electronic fuel injection (EFI) systems, the non-metallic material occasionally broke down and started leaking. Since leaking fuel in the hot engine compartment of a motor vehicle is extremely dangerous, any leakage from a fuel filter is unacceptable. Accordingly, metallic filters have been used in vehicle equipped with electronic fuel injection systems.

According to the present invention, it has been discovered that the material used in prior art non-metallic filters for electronic fuel injection fuel systems broke down and began leaking due to electrostatic buildup within the filter. Although the generation of electrical charges in hydrocarbon systems has been a recognized phenomena, it has been of little concern in the past, because the metallic components used in prior art systems provided an electrical path for the electrical charges to move freely to the grounded vehicle body. However, with non-conductive systems in which both the tubing and the filter are made from a non-conductive material, the pathway has been removed, leaving no way for the charges to drain to ground.

According to the present invention, a fuel filter for a motor vehicle is made from a moldable material which may be safely used in vehicles equipped with electronic fuel injection system....

'879 patent, col. 1, ll. 8-43.

C. Claim 1

The '879 patent was issued on November 17, 1992 and amended during reexamination in 1998. As amended, claim 1 of the '879 patent (broken down into appropriate clauses) reads:

A fuel injection system component for communicating fuel to the engine of a motor vehicle,

said motor vehicle having an electrical plane maintained at a predetermined electrical potential,

said fuel injection system component being made of a composite material comprising a polymer having *electrically conductive fibers* distributed randomly throughout the material to provide an electrically conductive path through said component between the fuel communicated through said component and said electrical plane,

so that at least a portion of the electrically conductive path extends through the component and *a conductive member leading to said electrical plane*

to thereby prevent the build-up of electrostatic charge in the fuel and the resultant arcing which causes the breakdown of the polymer material comprising the fuel injection system component.

The underlined words require interpretation by the Court.FN6 The four terms in claim 1 to be interpreted are:

FN6. *See* Defendants' Joint Identification of Ambiguous Claim Language for *Markman* Construction Purposes (Dec. 2, 2003).

(1) "fuel injection system component for communicating fuel to the engine of a motor vehicle,"

(2) "electrically conductive fibers,"

(3) "a conductive member leading to said electrical plane," and

(4) "thereby prevent the build-up of electrostatic charge in the fuel and the resultant arcing which causes the breakdown of the polymer material comprising the fuel injection system component."

D. The Problem

As will be explained further, the main disagreement between the parties is over the interpretation of "fuel injection system component." Honeywell says that the ordinary meaning of the term "component" broadly covers any constituent part of the fuel injection system, while defendants say that it is limited to a fuel filter. There are conflicting statements in the intrinsic record-the specification says that the "invention" is a fuel filter but the applicant stated during prosecution that the claim was meant to cover all types of components. The problem is further compounded by the fact that during prosecution, the applicant made an important change from claiming a "moldable material" to a "fuel system component" with no specific follow up from the examiner. As also will be explained, the unambiguous words of restriction in the specification overcome the prosecution history statements and limit the scope of claim 1 to a fuel filter.

E. Prosecution History of the '879 Patent

[1] Crucial to a proper interpretation of the claim terms at issue is a review of the prosecution history of the '879 patent. The '879 patent was a divisional patent application of U.S. Patent No. 5,076,920 (the '920 patent), from which U.S. Patent No. 5,164,084 (the '084 patent) also derived. The sequence of prosecutions is shown in the following diagram:

-> '084 Patent

Although Honeywell only asserts infringement of the '879 patent, it is proper to examine the prosecution history of all three patents. *See* Microsoft Corp. v. Multi-Tech Sys., Inc., 357 F.3d 1340, 1349 (Fed.Cir.2004) ("the prosecution history of one patent is relevant to an understanding of the scope of a common term in a second patent stemming from the same parent application"); Augustine Med., Inc. v. Gaymar Indus., Inc., 181 F.3d 1291, 1300 (Fed.Cir.1999); Laitram Corp. v. Morehouse Indus., Inc., 143 F.3d 1456, 1460 n. 2 (Fed.Cir.1998).

The evolution of the claims in the three patents is shown in Exhibit A.

1. The '920 Parent Patent Application: "Method"

The '920 patent application for an "Electrostatically Dissipative Fuel Filter" was filed on August 30, 1990. It included three sets of claims: (1) claims directed to a method for preventing material breakdown of the housing of a fuel filter, (2) claims directed to a fuel filter, and (3) claims directed to a "moldable material for fuel system components."

In the Office Action of April 1, 1991, the examiner found that the application claimed three independent and distinct inventions and therefore ordered the applicant to restrict the application to only one of the inventions pursuant to 35 U.S.C. s. 121. The examiner characterized the three inventions as follows:

I. Claims 1-10, drawn to a method for preventing material breakdown of a housing of a fuel filter, classified in Class 210, subclass 251.

II. Claims 11-16, drawn to fuel filter, classified in Class 210, subclass 243.

III. Claims 17-20, drawn to a moldable polymeric material, classified in Class 252, subclass 519.

Regarding the third invention, the examiner stated that the moldable material was distinct from the other inventions because it was for "a thermoplastic material containing an electrically conductive filler material such as stainless steel fibers. Electrically conductive polymeric materials have utility separate from use in a housing of a fuel filter as claimed."

The applicant elected to pursue the method claims in the '920 patent application and filed two divisional applications for the other sets of claims. The divisional application claiming a fuel filter ultimately issued as the '084 patent and the divisional application claiming a moldable polymeric material ultimately issued as the '879 patent. All three patents have the same specification and drawing.

On December 31, 1991, the method claims issued as the '920 patent for an "Electrostatically Dissipative Fuel Filter." Generally, the '920 patent covers a method for preventing arcing and the corresponding breakdown of the housing of a fuel filter by incorporating electrically conductive material in the ordinarily non-conductive housing material. Reexamination of the '920 patent was granted on two occasions; the claims were amended each time and allowed. Each claim of the '920 patent is now directed to a "method of preventing material breakdown of a housing of a fuel injection system fuel filter."

2. The '084 Divisional Patent Application: "Fuel Filter"

The '084 divisional patent application initially included claims directed to a "fuel filter" with specific properties. On November 4, 1991, the applicant filed a preliminary amendment adding claims directed to a

"fuel system component." In the Office Action of January 15, 1992, the examiner found that the "fuel filter" invention and the "fuel system component" invention were distinct:

I. Claims 11-16 and 21-31, drawn to a fuel filter, classified in Class 210, subclass 446.

II. Claims 32-35, drawn to a fuel system component, classified in Class 123, subclass 445.

The examiner required restriction because, among other reasons, "the fuel system component of Group II does not specifically require that the component be a fuel filter." The applicant then withdrew the "fuel system component" claims choosing to pursue only the "fuel filter" claims in the '084 patent application.

On November 17, 1992, the "fuel filter" claims issued as the '084 patent for an "Electrostatically Dissipative Fuel Filter." Generally, the '084 patent covers a fuel filter with filtering media inside that provides a conductive path from the fuel to a common electrical plane. The fuel filter prevents arcing and the corresponding breakdown of the housing. Reexamination of the '084 patent was granted on two occasions; the claims were amended each time and allowed. Each claim of the '084 patent is now directed to a "fuel injection system fuel filter for filtering fuel."

3. The '879 Divisional Patent Application: "Moldable Material" FN7

FN7. As will be explained, the '879 patent application initially claimed a "moldable material" but was amended during prosecution to claim a "fuel system component" instead.

a. Initial Examination

The '879 divisional patent application initially included independent claim 17:

Moldable material for fuel system components for communicating fuel to the engine of a motor vehicle, said motor vehicle having a common electrical plane maintained at a common electrical potential, said material comprising a polymer material having electrically conductive fibers distributed randomly throughout the material to provide an electrically conductive path through said components between the fuel communicated through said components and said common electrical plane.

The Office Action of September 25, 1991 rejected claim 17 for indefiniteness under 35 U.S.C. s. 112, para. 2 because, among other reasons, it was "not clear what fuel system components are intended to be constructed of the electrically conductive moldable material." Claim 17 was also rejected as anticipated by or obvious over two pieces of prior art. Specifically, the examiner found that U.S. Patent No. 4,664,971 to Soens disclosed "an electrically conductive molding composition comprising a polymeric resin having electrically conductive fibers randomly and uniformly dispersed therein" and U.S. Patent No. 4,675,143 to Wakita et al. taught the "addition of stainless steel fibers having the claimed dimensions, and in the amount claimed, to nylon resins." Although neither reference disclosed incorporating electrically conductive fibers in a moldable material for use specifically in a fuel system component, the examiner stated that such disclosure was not necessary because the applicant claimed the material itself, not a product or use of a product.

On November 4, 1991, the applicant filed an amendment to claim 17. Instead of amending the claim to cover a "moldable material for a certain type of component," the applicant chose to claim the "fuel system component" FN8 itself (additions underlined, deleted elements in brackets):

FN8. The applicant added "fuel system component" claims to both the '084 patent application and the '879 patent application on the same day. Apparently, the applicant intended to cover all of his bases by including

the claims in both applications in the event that the examiner required restriction in the other.

[Moldable material for fuel] *Fuel* system component[s] for communicating fuel to the engine of a motor vehicle, said motor vehicle having [a common] *an* electrical plane maintained at a [common] *predetermined* electrical potential, said *fuel system component being made of a composite* material comprising a polymer [material] having electrically conductive fibers distributed randomly throughout the material to provide an electrically conductive path through said component[s] between the fuel communicated through said component[s] and said [common] electrical plane, *so that at least a portion of the electrically conductive path extends through the component to thereby prevent the build-up of electrostatic charge in the fuel.*

The new claim changed the plural term "components" to the singular term "component." In response to the examiner's rejection for indefiniteness, the applicant stated (emphasis added):

The Examiner also states that "it is not clear what fuel system components are intended to be constructed of the electrically conductive moldable material." It is Applicant's position that any and/or all fuel system components can be constructed from this moldable material. The specification specifically refers to housings of fuel filters and fuel lines, but It is Applicant's position that he is entitled to a claim broad enough to cover all fuel system components manufactured of the moldable material disclosed and claimed in the specification.

In response to the examiner's obviousness rejection, the applicant argued (emphasis added):

Both Soens and Wakita et al. disclose a polymer material with electrically conductive fibers embedded therein. However, in both of these patents, the material is used in a housing which shields electrical appliances from emitting electromagnetic radiation. They have nothing to do with fuel, fuel systems, or even automobiles. Claims 17-20 have been amended to recite a fuel system component made of the material including the conductive fibers to establish an electrically conductive path to the electrical plane to prevent build up of electrostatic charges in fuel or any other liquid medium. Obviously, Wakita or Soens are not concerned with preventing the build up of electrostatic charges. Accordingly, Applicant respectfully asserts that it is not obvious to manufacture a fuel system component from the recited materials, even though the materials themselves are obvious in view of the cited references. Accordingly, Claims 17-20 are believed to be patentable.

The applicant therefore acknowledged that the moldable material was obvious in view of Soens and Wakita (which disclosed polymeric resins incorporating electrically conductive fibers) but argued that the component made from the moldable material was not. Thus, the applicant apparently switched from "moldable material" to "fuel system component" to further specify that his invention was for use in a fuel system and distinguish Soens and Wakita, which were not for use in a fuel system.

The Office Action of March 11, 1992 rejected claim 17 as obvious over French Patent 1,541,025 (the French patent) in view of U.S. Patent No. 3,186,551 to Dornauf and either Soens or Wakita. The examiner stated that the French patent disclosed a fuel filter made from a composite material containing metallic materials or powders. The French patent, however, was directed to a different purpose than the applicant's invention-it added the conductive material to improve heat exchange in the filter, while the applicant's invention added conductive fibers to prevent electrostatic charge. The examiner found this difference in purpose immaterial because "[t]he fuel filter of the French patent will inherently have the property of dissipating electrical (static) charge build-up, so it is irrelevant that the French patent did not set out to achieve this specific objective." The examiner stated that it would have been obvious to combine the French patent with Soens and Wakita to construct a fuel filter with conductive fibers for the purpose of dissipating electrostatic charge.

On May 18, 1992, the applicant filed an Amendment Under 37 C.F.R. 1.116 FN9 changing the title of the application to "Electrostatically Dissipative Fuel System Component" and traversing the examiner's

obviousness rejection. The applicant distinguished the French patent because it dealt with thermal conductivity not electrostatic charge build-up and did not include an electrically conductive path between the component and the vehicle body.

FN9. A Rule 116 amendment is an amendment after final action. 37 C.F.R. s. 1.116 (2004).

On June 18, 1992, the applicant and the examiner conducted an interview where they agreed on the following Examiner's Amendment to claim 17, which added an "arcing" limitation (additions underlined):

Fuel system component for communicating fuel to the engine of a motor vehicle, said motor vehicle having an electrical plane maintained at a predetermined electrical potential, said fuel system component being made of a composite material comprising a polymer having electrically conductive fibers distributed randomly throughout the material to provide an electrically conductive path through said component between the fuel communicated through said component and said electrical plane, so that at least a portion of the electrically conductive path extends through the component to thereby prevent the build-up of electrostatic charge in the fuel *and the resultant arcing which causes the breakdown of the polymer material comprising the fuel system component.*

The '879 patent subsequently issued on November 17, 1992 with claim 17 renumbered as claim 1.

b. Reexamination

On February 7, 1997, a third party requested reexamination of the '879 patent citing three Japanese patents as unconsidered prior art: JP-A-61-8102, JP-U-50-77878 (JP-77878), and JP-U-63-54859 (JP-54859). The third party said that reexamination was warranted because the Japanese patents disclosed the very structure that allegedly distinguished the '879 patent from the prior art-"an electrically conductive path between fuel within a fuel system component and a common electrical plane." The PTO granted the request on May 1, 1997.

In the Office Action in Reexamination of December 9, 1997, claim 1 was rejected as obvious over the state of the prior art in view of JP-77878. The examiner stated:

JP-77878 discloses that electrostatic charges may build up in fuel filters having nonconductive resin housings and that sparks generated by such charges can cause leakage in the filter housing. JP-77878 alleviates this sparking by introducing conductive carbon fibers into the electrically nonconductive resin that makes up the housing, thus providing a conductive means that extends completely through the housing, and being effective to prevent the build-up of electrostatic charge in the fuel flowing through the filter and to thereby prevent arcing which causes break-down of the electrically nonconductive housing material.... JP-77878 discloses a filtering medium which divides the filter housing into an inlet chamber communicated within an inlet fitting and an outlet chamber communicated within an outlet fitting, and it is submitted that the inlet chamber is adjacent a housing wall containing the electrically conductive carbon fibers embedded within the nylon housing material, and that such housing wall thus provides "an electrically conductive path through said component between the fuel communicated through said component and said electrical plane, so that at least a portion of the electrically conductive path extends through the component" as recited in claim 1....

On March 9, 1998, the applicant amended claim 1 to read (additions underlined, deleted elements in brackets):

[Fuel] *A fuel injection* system component for communicating fuel to the engine of a motor vehicle, said

motor vehicle having an electrical plane maintained at a predetermined electrical potential, said fuel system component being made of a composite material comprising a polymer having electrically conductive fibers distributed randomly throughout the material to provide an electrically conductive path through said component between the fuel communicated through said component and said electrical plane, so that at least a portion of the electrically conductive path extends through the component *and a conductive member leading to said electrical plane* to thereby prevent the build-up of electrostatic charge in the fuel and the resultant arcing which causes the breakdown of the polymer material comprising the fuel *injection* system component.

The amendment added two new limitations to claim 1:(1) it limited the claim to a "fuel injection system component," and (2) it specified that the electrically conductive path included "a conductive member leading to" the electrical plane. The applicant argued that the Japanese patents were directed to a fuel filter for use in a fuel system that only "occasionally" generated static electricity, while a fuel injection system constantly generates static electricity. The applicant further argued that the filters disclosed in the Japanese patents did not include a conductive member between the filter and a common electrical plane of the motor vehicle.

On June 30, 1998, claim 1 was allowed as amended. Reexamination Certificate B1 5,164,879 subsequently issued on September 8, 1998 with the title "Electrostatically Dissipative Fuel Filter." FN10

FN10. The '879 patent issued with the title "Electrostatically Dissipative Fuel System Component" but the title of the Reexamination Certificate is "Electrostatically Dissipative Fuel Filter." It is unknown why the title changed during reexamination because no amendment appears in the prosecution history. However, the applicant did not object to the title change. Although not particularly relevant to the interpretation of words in a claim, patent applicants are required to give a title and abstract so that the public can determine quickly the "gist" of the technical disclosure. *See* 37 C.F.R. s. 1.72 (2004).

III. Claim Interpretation Generally

[2] Claim interpretation is a matter of law for the Court. *Markman v. Westview Instruments, Inc.*, 52 F.3d 967, 979 (Fed.Cir.1995) (en banc), *aff'd*, 517 U.S. 370, 116 S.Ct. 1384, 134 L.Ed.2d 577 (1996). The focus is on "what one of ordinary skill in the art at the time of the invention would have understood the term to mean." *Id.* at 986. The first step in construing a patent claim is to examine the intrinsic evidence:

First, we look to the words of the claims themselves, both asserted and nonasserted, to define the scope of the patented invention. Although words in a claim are generally given their ordinary and customary meaning, a patentee may choose to be his own lexicographer and use terms in a manner other than their ordinary meaning, as long as the special definition of the term is clearly stated in the patent specification or file history.

Thus, second, it is always necessary to review the specification to determine whether the inventor has used any terms in a manner inconsistent with their ordinary meaning. The specification acts as a dictionary when it expressly defines terms used in the claims or when it defines terms by implication.... The specification contains a written description of the invention which must be clear and complete enough to enable those of ordinary skill in the art to make and use it. Thus, the specification is always highly relevant to the claim construction analysis. Usually, it is dispositive; it is the single best guide to the meaning of a disputed term.

Third, the court may also consider the prosecution history of the patent, if in evidence. This history contains the complete record of all the proceedings before the Patent and Trademark Office, including any express representations made by the applicant regarding the scope of the claims. As such, the record before the

Patent and Trademark Office is often of critical significance in determining the meaning of the claims. Included within an analysis of the file history may be an examination of the prior art cited therein.

Vitronics Corp. v. Conceptronic, Inc., 90 F.3d 1576, 1582 (Fed.Cir.1996) (citations omitted).

Ordinary meaning, however, is not the end of the analysis; the specification and prosecution history must also be studied to determine if it is appropriate to afford a claim term its ordinary meaning. *Kumar v. Ovonic Battery Co.*, 351 F.3d 1364, 1367-68 (Fed.Cir.2003). The Federal Circuit recently explained the "twin axioms" regarding the role of the specification in claim construction:

On the one hand, claims must be read in view of the specification, of which they are a part. On the other hand, it is improper to read a limitation from the specification into the claims. Although parties frequently cite one or the other of these axioms to us as if the axiom were sufficient, standing alone, to resolve the claim construction issues we are called upon to decide, the axioms themselves seldom provide an answer, but instead merely frame the question to be resolved. We have recognized that there is sometimes a fine line between reading a claim in light of the specification, and reading a limitation into the claim from the specification. As we have explained, an inherent tension exists as to whether a statement is a clear lexicographic definition or a description of a preferred embodiment. The problem is to interpret claims in view of the specification without unnecessarily importing limitations from the specification into the claims. That problem can present particular difficulties in a case such as this one, in which the written description of the invention is narrow, but the claim language is sufficiently broad that it can be read to encompass features not described in the written description, either by general characterization or by example in any of the illustrative embodiments.

Libel-Flarsheim Co. v. Medrad, Inc., 358 F.3d 898, 904 (Fed.Cir.2004) (citations and quotation marks omitted); *see also Slimfold Mfg. Co. v. Kinkead Indus., Inc.*, 810 F.2d 1113, 1116 (Fed.Cir.1987) ("Claims are not interpreted in a vacuum, but are part of and are read in light of the specification.").

[5] [6] [7] Thus, in certain situations, the specification or prosecution history may show an intent to depart from the ordinary meaning of a claim term. *CCS Fitness, Inc. v. Brunswick Corp.*, 288 F.3d 1359, 1366-67 (Fed.Cir.2002). For example, the patentee may act as his own lexicographer and explicitly define a term in the specification or prosecution history. *Id.* The patentee may also characterize "the invention in the intrinsic record using words or expressions of manifest exclusion or restriction, representing a clear disavowal of claim scope." *Teleflex, Inc. v. Ficoso North America Corp.*, 299 F.3d 1313, 1327 (Fed.Cir.2002); *see Alloc, Inc. v. ITC*, 342 F.3d 1361, 1377 (Fed.Cir.2003) ("a claim term will not carry its ordinary meaning if the intrinsic evidence shows that the patentee limited the scope of the claims"). If the "specification makes clear that the invention does not include a particular feature, that feature is deemed to be outside the reach of the claims of the patent" even if the language itself might be broad enough to cover the feature in question. *SciMed Life Sys., Inc. v. Advanced Cardiovascular Sys., Inc.*, 242 F.3d 1337, 1341 (Fed.Cir.2001). Similarly, "when the preferred embodiment is described in the specification as the invention itself, the claims are not necessarily entitled to a scope broader than that embodiment." *Modine Mfg. Co. v. ITC*, 75 F.3d 1545, 1551 (Fed.Cir.1996), *abrogated on other grounds by Festo Corp. v. Shoketsu Kinzoku Kogyo Kabushiki Co.*, 234 F.3d 558 (Fed.Cir.2000), *rev'd by* 535 U.S. 722, 122 S.Ct. 1831, 152 L.Ed.2d 944 (2002). However, simply because the specification describes only one embodiment of the invention does not mean that the claims should automatically be limited to that embodiment. *Libel-Flarsheim*, 358 F.3d at 906. Above all, the intrinsic evidence must show a clear and unmistakable intent to limit claim scope in order to overcome ordinary meaning and narrow a claim. *Id.*

[8] [9] [10] If the meaning of a claim term can be determined from the intrinsic evidence alone, it is improper to review extrinsic evidence. *Bell Atlantic Network Servs., Inc. v. Covad Communications Group*,

Inc., 262 F.3d 1258, 1268-69 (Fed.Cir.2001). "However, in the rare circumstance that the court is unable to determine the meaning of the asserted claims after assessing the intrinsic evidence, it may look to additional evidence that is extrinsic to the complete document record to help resolve any lack of clarity." *Id.* at 1269. Extrinsic evidence includes "expert testimony, articles, and inventor testimony." *Id.* While extrinsic evidence may also be used to aid in comprehension of the relevant technology, it may never be used to expand or limit claim language as it is defined, even by implication, in the specification or prosecution history. *Id.*; *Altiris*, 318 F.3d at 1369; *Pitney Bowes, Inc. v. Hewlett-Packard Co.*, 182 F.3d 1298, 1308 (Fed.Cir.1999).

IV. Analysis

The respective positions of the parties on interpretation of the ambiguous terms are displayed in Exhibit B. As previously stated, the following terms of claim 1 must be interpreted:

- (1) "fuel injection system component for communicating fuel to the engine of a motor vehicle,"
- (2) "electrically conductive fibers,"
- (3) "a conductive member leading to said electrical plane," and
- (4) "thereby prevent the build-up of electrostatic charge in the fuel and the resultant arcing which causes the breakdown of the polymer material comprising the fuel injection system component."

A. "Fuel Injection System Component for Communicating Fuel to the Engine of a Motor Vehicle"

Claim 1 requires a "fuel injection system component for communicating fuel to the engine of a motor vehicle."

[11] Honeywell says that giving all of the words their plain meaning, the claim term should be interpreted to mean "any part of the fuel injection system of a motor vehicle through which fuel flows on its way to the engine." Defendants, by contrast, say that the term means a "fuel filter for transmitting fuel to the engine of a motor vehicle and not away from the engine." Thus, the basic dispute between the parties is over the proper interpretation of the term "fuel injection system component." Honeywell says that it means "any part" of the fuel injection system, while defendants say that it should be limited to a "fuel filter."

1. Ordinary Meaning of the Term "Component"

First, the ordinary meaning of the term "component" is clear. A "component" is a "constituent part" or "constituent element" of something. *See Oxford English Dictionary* (2d ed.1989), *available at OED Online* <[http:// dictionary.oed.com](http://dictionary.oed.com)>; *Webster's New Collegiate Dictionary* 229 (1979). It is a broad term not limited to any particular part. Therefore, based solely on the ordinary meaning of the word "component," the term "fuel injection system component" refers to any constituent part of the fuel injection system of a motor vehicle including, for example, fuel filters, fuel lines, and connectors.

2. Specification

Next, the specification and prosecution history must be referenced to determine whether the patentee intended anything different than the ordinary meaning of "fuel injection system component."

a. Applicable Law

[12] It is a well established canon of claim construction that when a particular embodiment is described in

the specification as the invention itself, and not just one way of utilizing it, the claims are not entitled to a scope broader than that embodiment. *See* *Network, LLC v. Centraal Corp.*, 242 F.3d 1347, 1352 (Fed.Cir.2001); *Wang Labs., Inc. v. America Online, Inc.*, 197 F.3d 1377, 1383 (Fed.Cir.1999); *Modine*, 75 F.3d at 1551; *Autogiro Co. of Am. v. United States*, 181 Ct.Cl. 55, 384 F.2d 391, 398 (1967). For instance, if the specification calls an embodiment "the invention" or "the present invention," it is appropriate to limit the claims to that embodiment. *See, e.g.*, *Microsoft Corp. v. Multi-Tech. Sys. Inc.*, 357 F.3d 1340, 1348 (Fed.Cir.2004) ("in light of those clear statements in the specification that the invention ('the present system') is directed to communications 'over a standard telephone line,' we cannot read the claims ... to encompass data transmission over a packet-switched network such as the internet."); *SciMed*, 242 F.3d at 1343-44 (holding that "the characterization of the coaxial configuration as part of the 'present invention' is strong evidence that the claims should not be read to encompass the opposite structure"); *Watts v. XL Sys., Inc.*, 232 F.3d 877, 882-84 (Fed.Cir.2000) (finding that "the specification actually limits the invention to structures that utilize misaligned taper angles, stating that 'the present invention utilizes [the varying taper angle] feature' "). The context in which the embodiment is described must always be considered to determine if the embodiment is the "invention" or just the "preferred embodiment." *Wang Labs.*, 197 F.3d at 1383; *Cultor Corp. v. A.E. Staley Mfg. Co.*, 224 F.3d 1328, 1331 (Fed.Cir.2000) ("Whether a claim must, in any particular case, be limited to the specific embodiment presented in the specification, depends in each case on the specificity of the description of the invention and on the prosecution history. These sources are evaluated as they would be understood by persons in the field of the invention."). This is consistent with the axiom that statements in the specification must be clear in order to narrow the scope of a claim. *See Teleflex*, 299 F.3d at 1327.

b. Analysis

The term "fuel injection system component" does not appear in the specification. The word "component" appears in the abstract and once in the specification. *See* '879 patent, Abstract; *id.*, col. 1, ll. 30-35 (stating that the generation of electrostatic charge was "of little concern in the past, because the metallic components used in prior art systems provided an electrical path for the electrical charges to move freely to the grounded vehicle body"). None of these references explicitly define the claim term "fuel injection system component." The specification, however, describes the "invention" at various places:

This invention relates to a fuel filter for use in the fuel line that delivers fuel to a motor vehicle engine.

Id., col. 1, ll. 8-9 (emphasis added).

According to the present invention, it has been discovered that the material used in prior art non-metallic filters for electronic fuel injection systems broke down and began leaking due to electrostatic buildup within the filter.

Id., col. 1, ll. 26-30 (emphasis added).

According to the present invention, a fuel filter for a motor vehicle is made from a moldable material which may be safely used in vehicles equipped with electronic fuel injection system. This and other advantages of the present invention will become apparent from the following description, with reference to the accompanying drawing, the sole Figure of which is a cross-sectional view of a fuel filter made pursuant to the teachings of the present invention and its attachment to an associated automotive body.

Id., col. 1, ll. 40-49 (emphasis added).

According to the present invention, an electrically conductive path is provided between the fuel within the inlet cavity 42 [of the fuel filter 10] and the body 38.

Id., col. 3, ll. 41-43 (emphasis added).

The entire specification of the '879 patent, as well as the sole drawing, describe the elements and operation of a fuel filter with electrically conductive fibers. No other parts are described. A fuel filter is the sole embodiment of the invention disclosed in the specification. This fact is not enough to limit a claim's scope, though; there must be something more to establish "a clear intention to limit the claim scope using 'words or expressions of manifest exclusion or restriction.'" *Liebel-Flarsheim*, 358 F.3d at 906. Here, the specification never states that the patentee invented a "component" with particular features, the preferred embodiment of which is a fuel filter, FN11 but instead repeatedly and consistently characterizes the "invention" and the "present invention" as a fuel filter, not any part in general. Importantly, there is absolutely nothing in the specification to contradict this characterization by implying that the invention is broader than a fuel filter or that a fuel filter is merely an example part. FN12 In short, the patentee characterized a fuel filter as the only embodiment of his invention, not merely a "preferred" version of all possible embodiments. *See Alloc*, 342 F.3d at 1369-71; *Toro Co. v. White Consol. Indus., Inc.*, 199 F.3d 1295, 1301-02 (Fed.Cir.1999); *General Am. Transportation Corp. v. Cryo-Trans, Inc.*, 93 F.3d 766, 770, 772 (Fed.Cir.1996). A person of ordinary skill in the art reading claim 1 in light of the specification would realize this.

FN11. At the *Markman* hearing, the Court directed Honeywell to provide a highlighted copy of the '879 patent showing the specification language supporting its broad interpretation. In its filing, Honeywell cited the following language:

... the sole Figure of which is a cross-sectional view of a fuel filter made pursuant to the teachings of the present invention and its attachment to an associated automotive body.

'879 patent, col. 1, ll. 46-49. Honeywell says that based on this language, the figure showing a fuel filter is merely one embodiment "made pursuant to the teachings of the present invention." This portion of the specification, however, characterizes what the inventor invented (and what he is therefore able to teach) as a fuel filter-the "present invention." It does not support Honeywell's broad interpretation. Moreover, the only language in the specification concerning other parts of the fuel system (e.g. fuel lines) refers to those parts as separate items, not as what the inventor invented. *See, e.g., id.*, col. 1, ll. 56-63 ("The inlet fitting 14 and outlet fitting 16 are connected into the fuel line which delivers fuel from the fuel tank to the engine. The fuel line may also be made of a non-conductive material. A filter element generally indicated by the numeral 18 is mounted within the housing 12 to filter fuel communicated through the fuel line."); *Id.*, col. 2, ll. 40-47 ("Although some electrical charge generation occurs in the fuel lines upstream and downstream of the filter due to stripping of electrons due to friction between the fuel and the walls of the fuel line, the charge generation due to the impact of the hydrocarbon paraffin against the media 20 may be as much as several orders of magnitude higher than the generation taking place in the lines themselves.").

FN12. For example, the boilerplate statement that other embodiments and variations will be readily apparent to persons of ordinary skill in the art, which appears in many patents after the written description and before the claims, is not present in the '879 patent.

While the ordinary meaning of the claim term "component" encompasses any constituent part, that meaning is overcome by the express statements in the specification characterizing the "invention" and the "present invention" as one particular constituent part-a fuel filter. The specification language could not be any clearer. Fairly read, it establishes a clear disavowal of claim scope. While Honeywell cites other cases where the specification did not limit the claims, none of the cases involved unambiguous "invention" or "present invention" language like in the '879 patent. *See, e.g., Liebel-Flarsheim*, 358 F.3d at 907-09 (concluding that the patent at issue could not be limited by the specification because, although the specification only disclosed one embodiment, it did not state that the suggested limitation was "an essential

component of the invention" and did not contain any disclaiming language); *Sunrace Roots Enterprise Co. v. Sun Victory Trading Co.*, 336 F.3d 1298, 1307-08 (Fed.Cir.2003) (concluding that the patent at issue was not limited by language in the specification because neither the specification nor the prosecution history clearly defined the invention as including the suggested limitation). Based on the '879 patent specification, construing "fuel injection system component" to mean any part (rather than just a fuel filter) would ignore binding Federal Circuit precedent, particularly *SciMed* and *Modine*. There is a heavy presumption of ordinary meaning in patent claim construction, but in this case the specification leads to the inescapable conclusion that the ordinary meaning of "fuel injection system component" simply does not apply.

3. Prosecution History

While the specification is abundantly clear in calling a fuel filter the "invention" or the "present invention," the prosecution history must also be analyzed to see if ordinary meaning is overcome.

a. Applicable Law

i. *Biogen*

[13] [14] [15] Representations made by an applicant during prosecution cannot be used to enlarge the content of the specification. *Biogen, Inc. v. Berlex Labs., Inc.*, 318 F.3d 1132, 1140 (Fed.Cir.2003). The focus of claim interpretation is not on the subjective intent of the patentee but rather "on the objective test of what one of ordinary skill in the art at the time of the invention would have understood the term to mean." *Markman*, 52 F.3d at 986. Hence, when the specification and prosecution history conflict, any ambiguities must be resolved in favor of the specification and claims because "the specification is the basic presentation by the applicant, and the claims represent the final product of a sometimes imperfect process." *Biogen*, 318 F.3d at 1140.

In *Biogen*, the '567 patent at issue related to DNA technology and, specifically, the production of human interferon in ovary cells. *Id.* at 1132. The essential issue was whether the claims were limited to the use of a single DNA "construct" to introduce genes into a host cell, even though the claims did not require a single construct. *Id.* at 1133-35. *Biogen*, the accused infringer, argued that the entire specification was directed to procedures using a single construct and did not describe any other configuration. *Id.* at 1136-37. In particular, the Summary of the Invention stated that "the present invention" utilized a single construct. *Id.* at 1136. *Berlex*, the patentee, argued that the complex prosecution history showed that the invention was the production of human interferon independent of the construct used. *Id.* at 1137. Although the '567 patent claims did not explicitly require a single construct, the '567 patent was the child of the '843 patent, which did require a single construct. *Id.* During prosecution, the applicant stated that patentability did not depend on any particular construct configuration and the '843 patent claims were only limited to a single construct because of a misunderstanding of the prior art, which was corrected in the '567 patent. *Id.* at 1138. In allowing the claims, however, the examiner stated that the claims were directed to a single construct. *Id.* The district court held that the examiner's reasons prevailed over the applicant's statement in light of the unambiguous specification language. *Id.* at 1139. The Federal Circuit agreed and affirmed the district court's narrow interpretation requiring a single construct:

The [district] court correctly viewed the prosecution history not for the examiner's or the applicant's subjective intent, but as an official record that is created in the knowledge that its audience is not only the patent examining officials and the applicant, but the interested public. Any ambiguity, as may be raised when dispute arises, requires the decisionmaker to focus objectively on the patent specification and claims, for the specification is the basic presentation by the applicant, and the claims represent the final product of a sometimes imperfect process. Representations during prosecution cannot enlarge the content of the specification, and the district court was correct in relying on the specification in analyzing the claims. Implementing these principles, the district court construed the claims to conform with the basis on which the

invention was presented in the specification.

The district court correctly ruled that the specification defines the invention as the use of a single DNA construct to introduce the linked human interferon gene and selectable marker gene into the host Chinese hamster ovary cell, and that the method and cell claims, as well as the construct claims, are so limited....

Id. at 1139-40 (citations omitted; emphasis added).

ii. *Housey*

[16] Another canon of claim construction is that in the "unusual case" when a "patent applicant ma[kes] two contradictory and irreconcilable affirmative representations of the contested limitation, ... the narrower interpretation trumps the broader interpretation." *Housey Pharms., Inc. v. Astrazeneca Uk Ltd.*, 366 F.3d 1348, 1356 (Fed.Cir.2004) (citing *Athletic Alternatives, Inc. v. Prince Mfg., Inc.*, 73 F.3d 1573, 1581 (Fed.Cir.1996)). The *Housey* rule is consistent with the Federal Circuit's holding in *Biogen* that an applicant's statement during prosecution cannot enlarge the content of the specification.

b. Analysis

There are two relevant statements in the prosecution history of the '879 patent. First, during prosecution of the '879 patent, the examiner stated that claim 17 directed to a "moldable material for fuel system components" was ambiguous as to what components could be made from the moldable material. The applicant responded (emphasis added):

It is Applicant's position that any and/or all fuel system components can be constructed from this moldable material. The specification specifically refers to housings of fuel filters and fuel lines, but it is Applicant's position that he is entitled to a claim broad enough to cover all fuel system components manufactured of the moldable material disclosed and claimed in the specification.

Second, during prosecution of the '084 patent, the examiner found that the claims directed to a "fuel filter" (in class 210) and the claims directed to a "fuel system component" (in class 123) were distinct and required restriction because the "fuel system component" claims did not "specifically require that the component be a fuel filter." The two sets of claims ultimately issued as different patents.

Based on these statements, Honeywell says that both the applicant and the examiner understood that "fuel injection system component" was broader than "fuel filter" and meant to cover all parts, and therefore the ordinary meaning of the term applies. However, the isolated statements alluding to a broader construction do not negate the specific disclaimer in the specification for three reasons.

First, the applicant's conclusory statement that he was entitled to "a claim broad enough to cover all fuel system components" cannot be used to enlarge the content of the specification. *See Biogen*, 318 F.3d at 1139-40. Similar to the patent at issue in *Biogen*, the entire specification of the '879 patent describes a fuel filter and repeatedly characterizes the "invention" or the "present invention" as a fuel filter. The applicant's statement during prosecution does not reflect the disclosure in the specification, which never changed from the original '920 patent application. Indeed, it would not have been possible to amend the specification to cover all constituent parts of a fuel injection system because doing so would have impermissibly added "new matter" to the patent application. The *Biogen* court particularly emphasized that an applicant's claim scope argument during prosecution cannot overcome the clear description of an invention in a patent specification. *Id.* at 1140. The applicant's unilateral statement here seems more like clever patent prosecution and is not enough to overcome the repeated unambiguous statements in the specification defining the invention as a fuel filter.

Second, the two prosecution history statements are not as clear as they might seem on a first read. For instance, the examiner did not respond to the applicant's statement that he was entitled to a claim covering all parts of a fuel system. Indeed, the examiner rejected the claim twice more based on prior art disclosing fuel filters (the French patent, Dornauf, and the Japanese patents). Further, during prosecution of the '084 patent, the examiner classified the "fuel filter" claims in class 210, subclass 446 (filters) and the "fuel system component" claims in class 123, subclass 445 (charge forming devices), but during prosecution of the '879 patent, the examiner never searched class 123. Therefore, it is reasonable to find that the examiner understood the disclosure to be limited to fuel filters.FN13

FN13. The applicant made a material change to the scope of the '879 patent by switching from "moldable material" to "fuel system component." While the applicant may have desired a claim that covered a moldable material for any type of constituent part, the limited disclosure in the specification (reflecting what the inventor actually contributed to the art) does not allow a claim for the constituent parts themselves. Rather, it expressly limits the invention to a fuel filter. Consequently, the examiner most likely should not have permitted the change. As stated, however, the examiner did not specifically respond to the change or the applicant's arguments.

Third, this is the unusual case described in *Housey* when an applicant makes two contradictory and irreconcilable affirmative representations and the narrower interpretation trumps the broader Interpretation. *See Housey*, 366 F.3d at 1356. The applicant repeatedly stated in the specification of the original '920 patent application (which remained the same for the '879 patent application) that the "invention" is a fuel filter, but later argued during prosecution of the '879 patent that claim 1 for a "fuel system component" was broad enough to cover all parts. These two representations are directly contradictory and irreconcilable. Consequently, the narrower specification language controls.

4. Conclusion

The Court is mindful of its obligation not to impermissibly import limitations from the specification into a patent claim. However, focusing objectively on the intrinsic evidence, which describes the fuel filter as the invention itself, the presumption of ordinary meaning is overcome. A person of ordinary skill in the art would not understand "fuel injection system component" to have a broader scope encompassing all constituent parts. Because the meaning of "fuel injection system component" can be determined from the intrinsic evidence alone, it is not necessary to review extrinsic evidence FN14 to resolve ambiguities in the intrinsic record.

FN14. Both parties submitted expert reports in support of their positions.

Accordingly, "fuel injection system component for communicating fuel to the engine of a motor vehicle" is interpreted as follows:

Fuel filter for transmitting fuel to the engine of a motor vehicle and not away from the engine.

B. "Electrically Conductive Fibers"

[17] Claim 1 requires a "fuel injection system component being made of a composite material comprising a polymer having electrically conductive fibers distributed randomly throughout the material."

Honeywell says that "electrically conductive fibers" mean "fibers of a material that conducts electricity,

including, without limitation, metal and carbon." Defendants say that the term should be interpreted to mean "metal fibers."

Once again, the ordinary meaning of the term is easily ascertained: an electrically conductive fiber is a fiber that conducts electricity. However, defendants say that like "fuel injection system component," the ordinary meaning does not apply because the specification makes clear that the invention only includes metal fibers.

The specification states that "the present invention" provides an electrical path from the fuel, to the filter housing, to a conductive member, and finally to the body of the vehicle. '879 patent, col. 3, ll. 41-47. The filter itself is made electrically conductive by incorporating small amounts of a "conductive filler material" in the base polymer. *Id.*, col. 3, ll. 47-52. By doing so, the housing substantially retains the desired property of moldability. *Id.* The specification then states:

Since the filler material must be chemically resistant to the fuel in the housing 12, a filamentary stainless steel fiber product with a high aspect ratio was selected as the filler material. Stainless steel also has the advantage of requiring smaller quantities for providing the required conductivity than other conductive fillers, such as carbon black, metal flakes and powders, and metallized microspheres which possess small aspect ratios.... Other electrically conductive fillers, such as the aforementioned carbon, act as stress concentrators and, at the relatively high filler loadings required to achieve conductivity, restrict the ability of the resin matrix to yield under stress. Also, the stainless steel fibers are ductile and non-rigid unlike straight or metallized carbon fibers or metallized inorganic fibers and whiskers. This allows stainless steel fibers to maintain their integrity better during melt-processing. Unlike the non-metallic fibers, stainless steel fibers also do not increase mechanical strength or stiffness of the base resin significantly. Other metal fibers with high aspect ratios can be satisfactorily substituted for stainless steel.

The aspect ratio of the stainless steel fibers used must be large enough to easily conduct electricity at low loadings, but small enough to be easily molded with the base polymer material into the final part.

Id., col. 3, ll. 53-62 (emphasis added).

Defendants say that because the specification expressly disparages other electrically conductive fillers such as carbon for various reasons, "electrically conductive fibers" must be limited to metal fibers. Defendants say that only metal fibers meet the competing objectives of conductivity and moldability.

The above disclosure, however, is not like the clear specification language defining the "invention" as a fuel filter. Rather, it is more consistent with characterizing metal fibers with a high aspect ratio (specifically stainless steel) as the preferred embodiment of the invention. The first reference to a conductive material calls it a "conductive filler material." The specification then states that stainless steel was chosen because it had various advantages over other filler materials, including (1) stainless steel is chemically resistant to fuel, (2) smaller quantities are needed to achieve conductivity, (3) stainless steel allows the base polymer to yield under stress, (4) stainless steel fibers maintain their integrity during melt-processing because they are ductile and non-rigid, and (5) stainless steel does not increase the stiffness of the base polymer significantly. Importantly, the specification states that carbon black is a "conductive filler" but, because it has a small aspect ratio, a greater quantity of carbon would be needed to achieve conductivity than if stainless steel were used. *Id.*, col. 3, ll. 56-60. The specification, while presenting stainless steel as a clearly superior conductive filler, never expressly states that non-metal conductive fillers like carbon cannot be used. Moreover, claim 1 requires conductivity but says nothing about the moldability or stiffness of the composite material. Like the fact that stainless steel can be used in smaller quantities and still make the polymer conductive, moldability and stiffness are merely preferences disclosed in the specification. *See E-Pass Techs., Inc. v. 3Com Corp.*, 343 F.3d 1364, 1370 ("An invention may possess a number of advantages or purposes, and there is no requirement that every claim directed to that invention be limited to encompass all

of them."). Metal fibers with a high aspect ratio are the preferred embodiment in the '879 patent specification, not the "invention."

The prosecution history further establishes that "electrically conductive fibers" cannot be limited to only metal fibers. The '920 patent application originally claimed a "method of preventing material breakdown of a housing of a fuel filter ... said housing being primarily composed of an electrically non-conductive material." In rejecting claim 1 for indefiniteness, the examiner stated that the claim "should be amended to recite that the housing of the fuel filter is made electrically conductive by incorporation therein of electrically conductive stainless steel fibers." The applicant responded by amending the claim to specifically require the addition of "electrically conductive material" in the housing. The applicant stated (emphasis added):

It is noted that the Examiner has commented that Claim 1 should be amended to recite the electrically conductive path is provided by incorporating electrically conductive stainless steel fibers in the housing material. However, Applicant respectfully urges that adding such a limitation would unduly narrow the claim. In fact, Applicant specifically discloses in the specification ... materials other than stainless steel fibers which could be used to provide the electrically conductive path, although the stainless steel fibers are preferred. Accordingly, Claim 1 now recites that an electrically conductive material is embedded in the housing, and this is believed to be sufficient to render the claims definite.

The claim was then allowed. The prosecution history therefore confirms that stainless steel fibers were the preferred (not the only) embodiment of an "electrically conductive material" in the '920 patent and, similarly, the preferred embodiment of "electrically conductive fibers" in the '879 patent. Further, during reexamination of the '879 patent, the examiner rejected the original claim as obvious because JP-77878 incorporated carbon "electrically conductive fibers" into a housing made from a nonconductive polymer.

The specification and prosecution history are consistent as to the "electrically conductive fibers" term. Neither source provides a basis to deviate from the ordinary meaning. Therefore, a broad interpretation is appropriate and "electrically conductive fibers" is interpreted as follows:

Fibers of a material that conducts electricity, including, without limitation, metal and carbon.

C. "A Conductive Member Leading to Said Electrical Plane"

[18] Claim 1 recites that a portion of the electrically conductive path extends through the fuel injection system component and "a conductive member leading to said electrical plane."

Honeywell says that "conductive member" means "any electrically conductive part or component-whether or not part of the fuel injection system-that forms at least part of the electrically conductive path that leads directly or indirectly to the electrical plane." Honeywell says that "electrical plane" means "any electrically conductive mass that can be maintained at a common electrical potential, including, without limitation, the body of an automotive vehicle."

Defendants say that "conductive member" means "an electrically conductive bracket directly attached to, or molded as a part of, the fuel filter housing." Defendants say that "electrical plane" means "an electrically conductive mass of the motor vehicle that is maintained at a predetermined electrical potential."

There are essentially two disagreements between the parties: (1) whether the "conductive member" can be any kind of electrically conductive part or whether it must be an electrically conductive "bracket," and (2) whether the "conductive member" may be physically separate from the housing or whether it must be attached to or molded as a part of the housing. Defendants say that their interpretation, which is narrower

than the ordinary meaning of the words, is warranted based on limiting language in the specification and prosecution history.

Referring to the sole figure in the '879 patent, the specification provides:

The housing 12 is secured to the metal vehicle body, a portion of which is indicated at 38, by a bracket 40. The bracket 40 may be either a separate metallic member attached to the housing 12 or molded as a part of the housing 12 from the same material used for the housing 12.

'879 patent, col. 2, ll. 14-19. The specification later states that the electrostatic charge build-up in the fuel cavity of the filter "will be discharged through the electrically conductive path in bracket 40 to the body 38" to prevent arcing. *Id.*, col. 3, ll. 41-47. The bracket 40 is the sole embodiment of a "conductive member" disclosed in the specification. However, the specification does not specifically state that a bracket is the only possible embodiment, nor does it state that the "conductive member" must be attached to the housing or molded as a part of the housing in every embodiment. The only requirement is that the "conductive member" allow for an electrically conductive path from the filter housing to the electrical plane.

The prosecution history also does not support defendants' narrow interpretation. Defendants point to the following statement in the applicant's March 9, 1998 amendment during reexamination:

Japanese Patent Document No. 63-54859 ("JP '859") was cited because it shows a fuel filter and includes structure for mounting the fuel filter to a vehicle. In more detail, the JP '859 document discloses a fuel filter 8 having a particular shape that conforms to a corner area of a vehicle to which it is mounted. Further, this reference teaches using a mounted portion 24 that is integrally formed with the case body 10 to mount the filter to the vehicle. This is done to avoid the necessity of using a bracket to mount the filter to the vehicle.

In any event, the JP '859 document is primarily concerned with the size and the shape of the fuel filter (and surrounding areas) disclosed therein, and is silent regarding materials of which the fuel filter or any other component of a fuel injection system is made. Patentees thus respectfully submit that JP '859 neither teaches nor suggests a bracket made of an electrically conductive material.

Defendants say that in distinguishing JP-54859, the applicant effectively required a conductive bracket that is directly attached to or molded as a part of the fuel filter housing. The applicant's statement, however, does not represent a clear disavowal of claim scope, especially considering that the applicant was responding to a rejection based on JP-77878, not JP-54859.

Neither the specification nor the prosecution history overcome the broad ordinary meaning of the term. "A conductive member leading to said electrical plane" is interpreted as follows:

Any electrically conductive part or component-whether or not part of the fuel injection system-that forms at least part of the electrically conductive path that leads directly or indirectly to the electrical plane, which is any electrically conductive mass that can be maintained at a common electrical potential, including, without limitation, the body of an automotive vehicle.

D. "Thereby Prevent the Build-up of Electrostatic Charge in the Fuel and the Resultant Arcing Which Causes the Breakdown of the Polymer Material Comprising the Fuel Injection System Component"

[19] Claim 1 recites that the fuel injection system component is made of a composite material with electrically conductive fibers to provide an electrically conductive path to ground and "thereby prevent the build-up of electrostatic charge in the fuel and the resultant arcing which causes the breakdown of the

polymer material comprising the fuel injection system component."

Honeywell says that the plain meaning of the phrase is "preventing the accumulation of electrons sufficient to create an arc that causes the polymer material of the fuel injection system component to deteriorate." Defendants say that the phrase means "preventing the accumulation of charge in the fuel such that arcing and deterioration of the polymer material used to make the housing [of the fuel filter] are avoided."

The interpretations proffered by the parties are quite similar. Indeed, the specification of the '879 patent describes the arcing phenomenon as follows:

[M]ost of the charge is concentrated in that part of the cavity 42 closest to the body 38. When a grounding plane, such as the body 38, is within "striking" distance of a charged body, the plane itself is a target for electron current flow. The energy which makes up the charge will then no longer pass through the body in an evenly distributed manner. This absorption of energy breaks down the material of which the housing 12 is made and results in microscopic pin holes in the housing 12. When a large concentration of these pin holes occurs in a small area, the material comprising the housing 12 breaks down and the housing leaks. Tests have shown that the striking distance is always less than or equal to the radius of the curved body.

'879 patent, col. 3, ll. 26-40. The essential difference between the interpretations is that Honeywell uses "fuel injection system component" while defendants use "housing [of the fuel filter]." Because "fuel injection system component" has already been interpreted to mean "fuel filter," *see supra*, Part IV.A, defendants' interpretation is correct.

The phrase "thereby prevent the build-up of electrostatic charge in the fuel and the resultant arcing which causes the breakdown of the polymer material comprising the fuel injection system component" is interpreted as follows:

Preventing the accumulation of charge in the fuel such that arcing and deterioration of the polymer material used to make the housing of the fuel filter are avoided.

V. Conclusion

Although four terms of the '879 patent are at issue, what really divides the parties is the proper interpretation of "fuel injection system component" and, specifically, whether the term encompasses all parts of a fuel injection system or simply a fuel filter. While the applicant may have initially focused on a patent covering a moldable material for use in the manufacture of fuel system parts to thereby capture all the parts of a fuel system made from the material, the applicant made a significant change during prosecution from claiming a "moldable material for fuel system components" to claiming the "fuel system component" itself. The specification does not support the change. It expressly indicates that the "invention" is not all constituent parts but rather a specific part—a fuel filter. To interpret "fuel injection system component" broadly as Honeywell suggests would require either (1) completely divorcing the ordinary meaning of the claim language from the intrinsic record, or (2) an analysis of the prosecution history of all three patents akin to biblical exegesis. The rules of claim interpretation do not permit either route.

This is a tentative decision. FN15 Experience in patent cases shows that subsequent proceedings and particularly trial may reveal aspects of claim interpretation not apparent at this point of the case in the papers.

FN15. The Court recognizes that the rules of claim interpretation may change with the forthcoming en banc decision from the Federal Circuit in *Phillips v. AWH Corp.*, No. 03-1269, 2004 WL 1627271 (Fed.Cir. July 21, 2004). However, there is no need to delay interpreting the claims in this case because, as always, a

Markman decision is tentative. If after the Federal Circuit issues its decision in *Phillips* either party believes the Court's claim interpretations are incorrect, it may move to reconsider this order.

The disputed terms in claim 1 of the '879 patent are interpreted as follows:

Term	Interpretation
fuel injection system component for communicating fuel to the engine of a motor vehicle	fuel filter for transmitting fuel to the engine of a motor vehicle and not away from the engine
electrically conductive fibers	fibers of a material that conducts electricity, including, without limitation, metal and carbon
a conductive member leading to said electrical plane	any electrically conductive part or component-whether or not part of the fuel injection system-that forms at least part of the electrically conductive path that leads directly or indirectly to the electrical plane, which is any electrically conductive mass that can be maintained at a common electrical potential, including, without limitation, the body of an automotive vehicle
thereby prevent the build-up of electrostatic charge in the fuel and the resultant arcing which causes the breakdown of the polymer material comprising the fuel injection system component	preventing the accumulation of charge in the fuel such that arcing and deterioration of the polymer material used to make the housing of the fuel filter are avoided

SO ORDERED.

EXHIBIT A

'920 PARENT APPLICATION

Claims 17-20

"Moldable material for fuel system components for communicating fuel to the engine of a motor vehicle..."

Claims 1-10

"Method of preventing material breakdown of a housing of a fuel filter for filtering fuel flowing through a fuel line delivering fuel to the engine of a motor vehicle..."

Claims 11-16

"Fuel filter for filtering fuel flowing through a fuel line for delivering fuel to the engine of a motor vehicle..."

Amendment

"Method of preventing material breakdown of a housing of a fuel filter ... to thereby prevent the build-up of electrostatic charge in the fuel and resulting arcing..."

Allowance

December 31, 1991

Reexamination Amendment

"Method of preventing material

breakdown of a housing of a fuel filter ... so that the electrically conductive material extends completely through the housing..."

Reexamination Amendment

"A method of preventing material breakdown of a housing of a fuel injection system fuel filter ... said housing being supported by an electrically conductive bracket..."

'879 PATENT APPLICATION

Amendment

"Fuel system component ... to thereby prevent the build-up of electrostatic charge in the fuel."

Amendment

"Fuel system component ... [to prevent] the resultant arcing which causes the breakdown of the polymer material..."

Allowance

November 17, 1992

Reexamination Amendment

"A fuel injection system component..."

'084 PATENT APPLICATION

Amendment

"Fuel filter ... said filtering media defining an inner cavity ... said filtering media cooperating with said housing to define an outer cavity..."

Amendment

"Fuel filter ... to prevent the build-up of electrostatic charge in the fuel ... and to thereby prevent arcing..."

Allowance

November 17, 1992

Reexamination Amendment

"Fuel filter ... said conductive means extending completely through the housing..."

Reexamination Amendment

"A fuel injection system fuel filter..."

EXHIBIT B

Claim Term	Honeywell's ell's Interpretation	Defendants' Interpretation
fuel injection system component for t for communicating fuel to the engine of a motor vehicle	any part of the fuel injection system of a motor vehicle through which fuel flows on its way to the engine	fuel filter for transmitting fuel to the engine of a motor vehicle and not away from the engine
electrically conductive fibers	fibers of a material that conducts electricity, including, without limitation, metal and carbon	metal fibers
a conductive member leading to said electrical plane	conductive member: any electrically conductive part or component- whether or not part of the fuel	conductive member: an electrically conductive bracket directly attached to, or molded as a part of, the fuel

	<p>injection system-that forms at least part of the electrically conductive path that leads directly or indirectly to the electrical plane electrical plane: any electrically conductive mass that can be maintained at a common electrical potential, including, without limitation, the body of an automotive vehicle</p>	<p>filter housing electrical plane: an electrically conductive mass of the motor vehicle that is maintained at a predetermined electrical potential</p>
<p>thereby prevent the build-up of electrostatic charge in the fuel and the resultant arcing which causes the breakdown of the polymer material comprising the fuel injection system component</p>	<p>preventing the accumulation of electrons sufficient to create an arc that causes the polymer material of the fuel injection system component to deteriorate</p>	<p>preventing the accumulation of charge in the fuel such that arcing and deterioration of the polymer material used to make the housing [of the fuel filter] are avoided</p>

Produced by Sans Paper, LLC.